

# MORCO

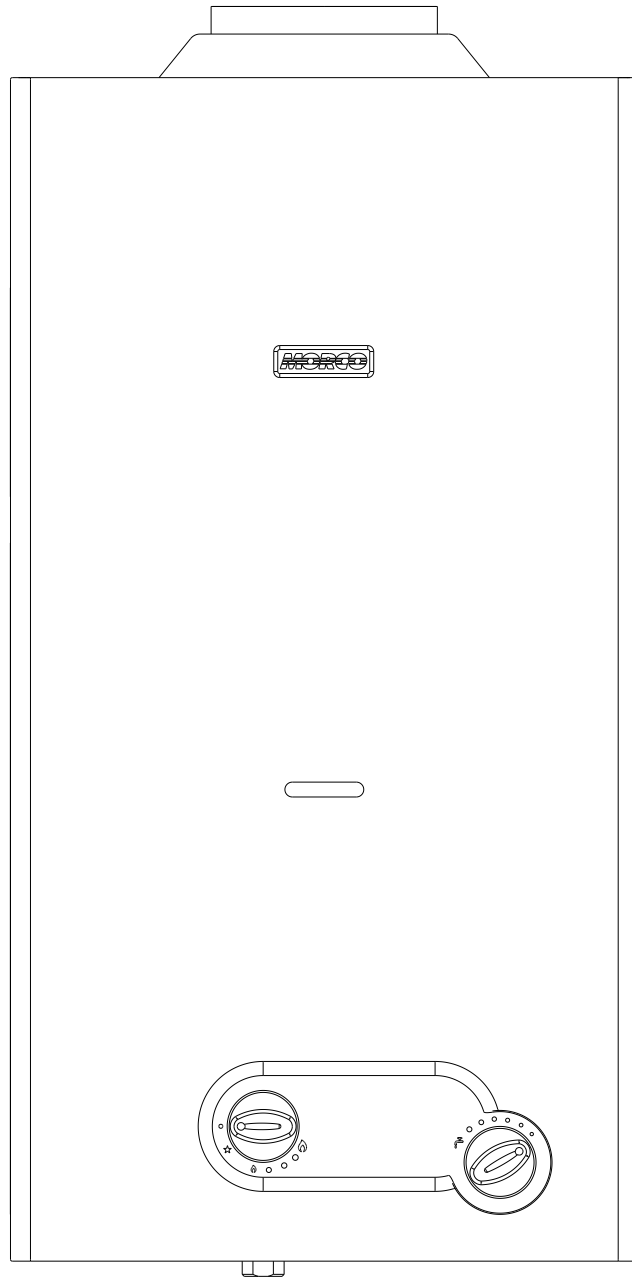

## **EUP6 - EUP11**

**Instantaneous gas water heater**

***User, Installation and Maintenance Manual***

The device is well built in accordance with the current legislation.

The CE sign positioned on the product indicates that it conforms to the following European Directives:

- Regulation Gas Appliance (UE) 2016/426
- European Standard: gas-fired instantaneous water heaters for the production of domestic hot water EN 26:2015
- Directive 2009/125/EC Ecodesign requirements for energy-related products
- Regulation (EU) 2017/1369 setting a framework for energy labelling
- Delegated regulation (EU) no. 812/2013
- Delegated regulation (EU) no. 814/2013



This appliance is certified to be placed in the following countries in relation to gas type and pressures:

**EUP6**

Cat. I3P (G31 - Propane @ 37 mbar): Belgium (BE), Spain (ES), France (FR), Great Britain (GB), Italy (IT), Holland (NL), Ireland (IE)

Cat. I3P (G31 Propane @ 50 mbar) Germany (DE), Austrian (AT)

**EUP11**

Cat. I3+ (G30/G31 - Butane/Propane @ 28-30/37 mbar): Belgium (BE), Spain (ES), France (FR), Great Britain (GB), Italy (IT), Ireland (IE)

Cat. I3P (G31 - Propane @ 37 mbar): Belgium (BE), Spain (ES), France (FR), Great Britain (GB), Italy (IT), Holland (NL), Ireland (IE)

Cat. I3B (G30 Butane @ 30 mbar): Belgium (BE), Spain (ES), France (FR), Great Britain (GB), Ireland (IE)

Cat. I3P (G31 Propane @ 50 mbar) Germany (DE), Austrian (AT)

The appliance complies with the Regulation (EU) 2017/1369 setting a framework for energy labelling.

The energy label carries the information regarding the product's energy efficiency characteristics.

In this way the end consumer can identify and compare similar products and can make informed choices regarding high efficiency appliances.

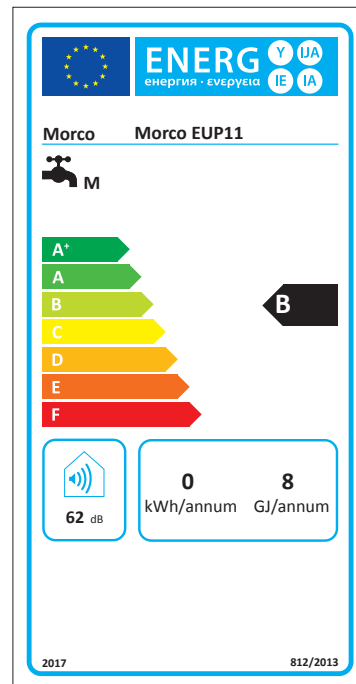
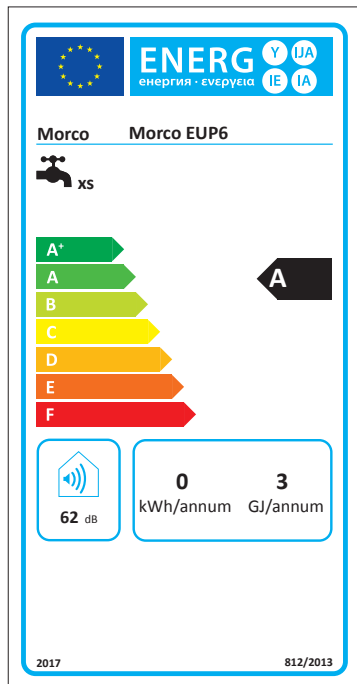

PRODUCT DATASHEET			
Morco		EUP6	EUP11
Declared load profile		XS	M
Indoor sound power level	dB(A)	62	62
Water heating energy efficiency class		A	B
Water heating energy efficiency class	%	48	58
Annual energy consumption	GJ	3	8
Nitrogen oxide emissions G31	mg/kWh	29	-
Nitrogen oxide emissions G30-G31	mg/kWh	-	61-20



## WARNING



This booklet contains information relevant to the user as well as the installer.



When the product has reached the end of its serviceable life, it shall be disposed of in an environmentally friendly way and disposed of according to the regulations in force.

Separate collection and recycling of the product avoid negative impact for environment and health, and allows recovery of materials, in order to obtain energy and resources saving

## Gas Safety (Installation and Use) Regulations 1998

In the interest of safety, it is the law that all gas appliances are installed and serviced by a competent person in accordance with the above regulations, building regulations, codes of practice and byelaws of the local water authority.

Failure to comply with the regulations may lead to prosecution. It is in your interests and that of your safety that the law is complied with.

### Related documents

The following British Standards, Codes of Practice and other Regulations must be observed in the installation of the water heater.

The Gas Safety Regulations (Installation and Use) 1998 The Model Water Byelaws

Byelaws of the Local Water Undertaking

The Building Regulations (Permanent Buildings) England and Scotland

BS 5482 Part 1 Installations in Permanent Dwellings

Non-Permanent Dwellings BS 5482 Part 3 Installations in Boats

BS EN 1949 Installation of LPG System for Habitational Purposes in Leisure Accommodation Vehicles

BS EN 721 Leisure Accommodation Vehicles - Ventilation Requirements

BS EN ISO 10239 2017 Small Craft LPG Systems

## CONTENTS

<b>GENERAL SAFETY WARNINGS</b>	page	4
<b>DESCRIPTION OF THE APPLIANCE</b>	page	4
<b>1 OPERATION</b>	page	5
1. a Function	page	5
1. b Usage	page	5
1. c Dimensions	page	6
1. d Components	page	7
<b>2 TECHNICAL CHARACTERISTICS</b>	page	8
2. a Technical Data	page	8
<b>3 INSTALLATION</b>	page	9
3. a Regulations	page	9
3. b Wall mounting	page	9
3. c Room ventilation	page	9
3. d Gas Connection	page	9
3. e Water connection	page	10
3. f Flue gas	page	10
<b>4 MAINTENANCE</b>	page	11
4. a Removing the casing	page	11
4. b Troubleshooting: Problems and solutions	page	11
<b>FOR THE ENGINEER</b>		
Starting up the appliance and final checks	page	12
<b>WINTERISATION</b>	page	13
<b>WARRANTY</b>	page	14

In parts of the manual the following symbols are used:



**WARNING** = for actions that require caution and adequate preparation













**PROHIBITED** = for actions that **MUST NOT** be performed

The water heater package contains:







- 2 Two knobs to attach to the control panel after installation
- 1 Water filter to insert in the water valve pipe fitting.

## GENERAL SAFETY WARNINGS

The User, Installation and Maintenance Manual is an integral part of the product and so must be carefully preserved in order to accompany the product; if it is lost or damaged another copy can be requested from Morco Products Limited on 01482 325 456 or visit our website [www.morcoproducts.co.uk](http://www.morcoproducts.co.uk).

-  The installation of the device and any other repairs or maintenance must be performed by a Gas Safe Engineer or other qualified personnel according to the law in force, in compliance with the installation regulations including any revisions.
-  A Gas Safe Engineer or other qualified personnel must commission this device.
-  The device must be used according to the manufacturer specifications. The manufacturer cannot be held contractually or otherwise responsible for damage caused to persons, animals or objects as a result of incorrect installation, repair or maintenance or improper usage.
-  The product's safety or automatic regulation devices must not be modified unless performed by the manufacturer.
-  This device is intended for heating water and therefore must be connected to a water distribution network whose flow and pressure are compatible with the product.
-  If water leaks are observed, turn off the water supply and advise a Gas Safe Engineer or other qualified personnel.
-  If the appliance is not used for prolonged periods turn off the gas supply. If there is a risk of the water freezing, empty the water heater. Please see "frost and freezing" on page 5.
-  If the machine breaks down or does not function properly, deactivate it, do not attempt to perform any repairs and contact a Gas Safe Engineer or other qualified person.
-  The appliance should be maintained at least once a year.
-  When the product has reached the end of its serviceable life, it shall be disposed of in an environmentally friendly way; ensuring that the majority of the product is fully recycled.

When using the device the following safety rules must be applied:

-  Do not use the machine for purposes other than those intended by the manufacturer.
-  Do not block the intake, flue or the ventilation openings in the area where the device is installed with rags, paper or any other materials.
-  If a gas leak is detected, do not switch on any electrical devices, telephones or any other objects that could produce a spark. Ventilate the area by opening the doors and windows and switch off the gas supply.
-  Do not place objects on top of the device.
-  Do not leave flammable containers or substances in the area where the device is installed.
-  Children or inexperienced persons should be prohibited from using the device.

## DESCRIPTION OF APPLIANCE

The Morco EUP6 and EUP11 are an open flued 6 and 11 litre instantaneous gas water heater.

The air for combustion comes from the external vents in the cupboard that the heater is placed in and hence very careful attention must be paid to providing sufficient ventilation. See section 3.c. Room Ventilation.

The appliance is suitable for use in dedicated boiler cupboards in caravan holiday homes.

The appliance relies on a pilot flame to ignite the main burner once a hot tap is opened.

The appliance does not store hot water.

The flow of the water through the appliance can be adjusted from 3 to 6 litres per minute (EUP6 model) and 5.5 to 11 litres per minute (EUP11 model) and this corresponds to the temperature of the incoming water being increased by 50°C or 25°C respectively.

This adjustment is made via the water temperature adjustment knob and during winter months it is advisable to move the knob fully clockwise to ensure hot water of an acceptable temperature.

# 1. OPERATION

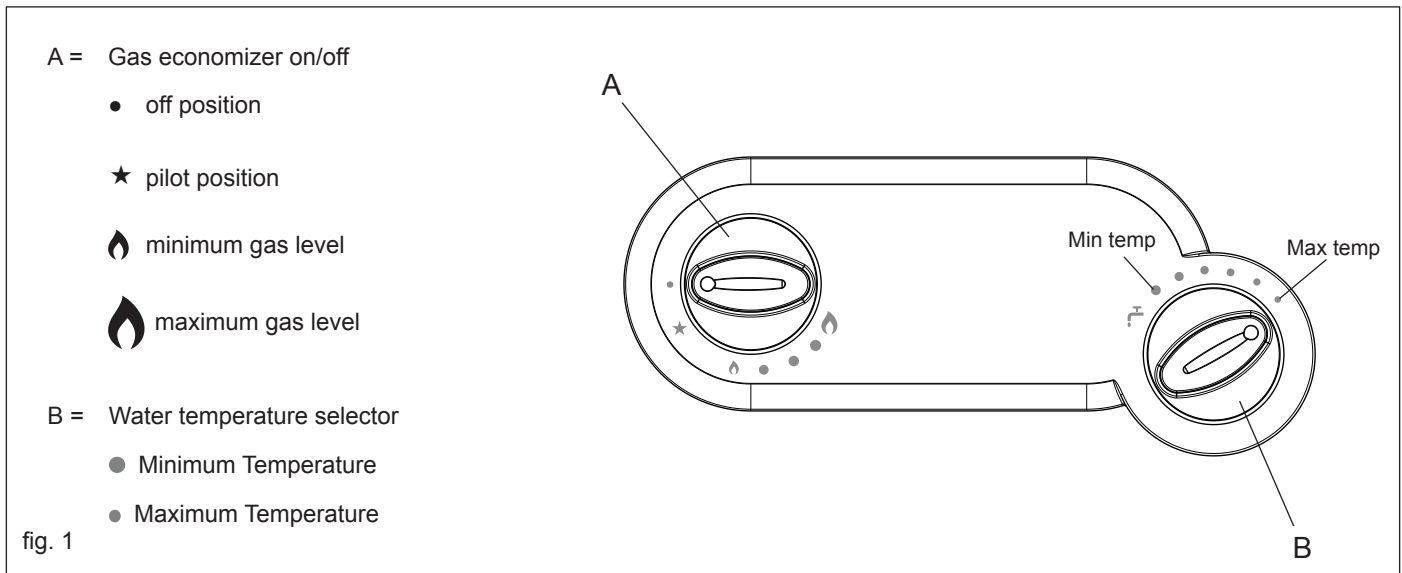

## 1.a. Function

The water heater is designed to produce instantaneous hot water. The hot water is delivered to several outlets around the home. If more than one outlet is used at any one time the delivery of hot water will be reduced at each outlet. The Water heater has 2 main controls:

- A gas control knob - "A" in fig 1
- A water temperature control knob - "B" in fig 1

The minimum gas level in fig. 1 will provide approximately 50% of the available power. Turning the gas control knob counter-clockwise will increase the power level between 50% and 100%. This function may be useful to vary the temperature of the water supplied.

The water temperature selector allows water to be supplied anywhere between 50% and 100% of the water heater's capability. In effect the selector reduces the water flow through the heater to the taps to increase the water temperature and correspondingly increases the water flow to reduce the water temperature.

In the UK the normal positions for the controls are:

- Gas control – always set to 100% (fully counter clockwise)
- Water control set to 100% (fully clockwise) during the winter months
- Water control set to between 100% and 50% during the summer months to suit the customer's preference for hot water temperature

## 1.b Usage

Ensure that the appliance gas isolation valve and all water taps are switched off

- Turn on the main external gas supply on the bottle or tank
- Light other gas appliances such as the cooker hob or fire and allow them to run for 30 seconds- this is to purge the gas system of air
- Open the appliance gas isolation valve, placed immediately below the water heater on the gas input pipe
- Rotate knob A to the pilot position (★), press the knob down all the way and keep it pressed
- Press the piezo electric button that is located under the water heater until the spark ignites the pilot flame. The flame can be seen through the viewing hole on the front of the heater by looking slightly upwards and to the left. When it ignites, keep the gas control knob ("A" in fig 1), pressed for 20-30 seconds. If the pilot does not stay lit when the knob is released, repeat the procedure

- Rotate Knob A towards the large flame (🔥), during rotation it is necessary to keep the knob pressed down lightly until the final position is reached
- From this moment the device is able to produce hot water on request. Opening the hot water tap causes the main burner to be ignited, and inversely, by closing the hot water tap the main burner is switched off; but the pilot flame remains switched on for future requirements
- If the main burner or pilot flame is accidentally turned off, the gas valve automatically blocks the output of gas within 60 seconds so to avoid any danger. To return the device to an operational mode, repeat the steps above

The machine is switched off by rotating knob A to the OFF position (●).

When the water heater is not used for long periods close the appliance gas isolation valve or the LPG gas valve on the bottle/ tank.

For the best operational results it is recommended to have a Gas Safe Engineer or other qualified personnel service the machine at least once a year.

## PRECAUTIONS TO BE TAKEN AGAINST FROST AND FREEZING CONDITIONS

If there is a possibility that the area where the appliance is installed could reach below 0°C, the device must be emptied of all water.

During cold spells, if your appliance is located in a place exposed to frost and freezing conditions, it must be drained down in the following way:

- Turn off the home's water inlet stop tap.
  - Disconnect the water supply pipe from the home
  - Open any drain cocks located on the hot/cold water pipework under the home
  - Turn on all hot and cold water taps
  - Turn appliance water temperature selector fully anticlockwise
  - Disconnect the cold water inlet to the water heater
  - Full details of winterisation can be found under "troubleshooting" at [www.morcoproducts.co.uk](http://www.morcoproducts.co.uk)
  - A summary can be found on page 13 of this manual
- To use the appliance again reverse the above procedure

# 1.c Dimensions

fig. 2

## EUP6

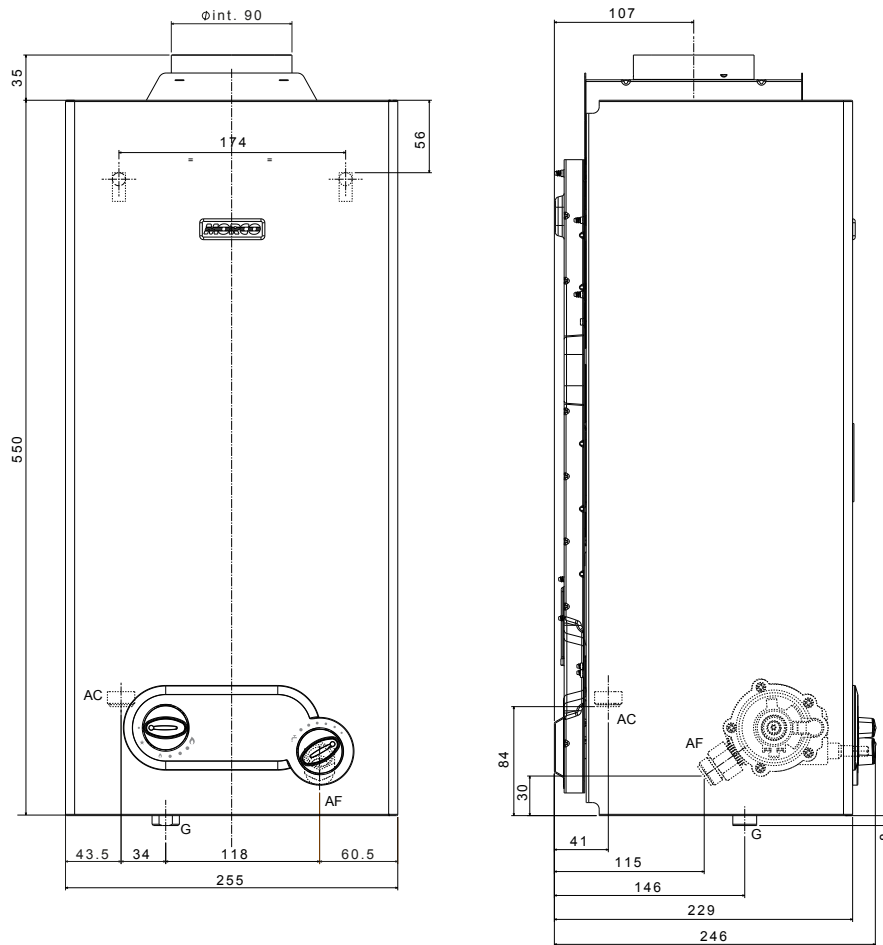

## EUP11

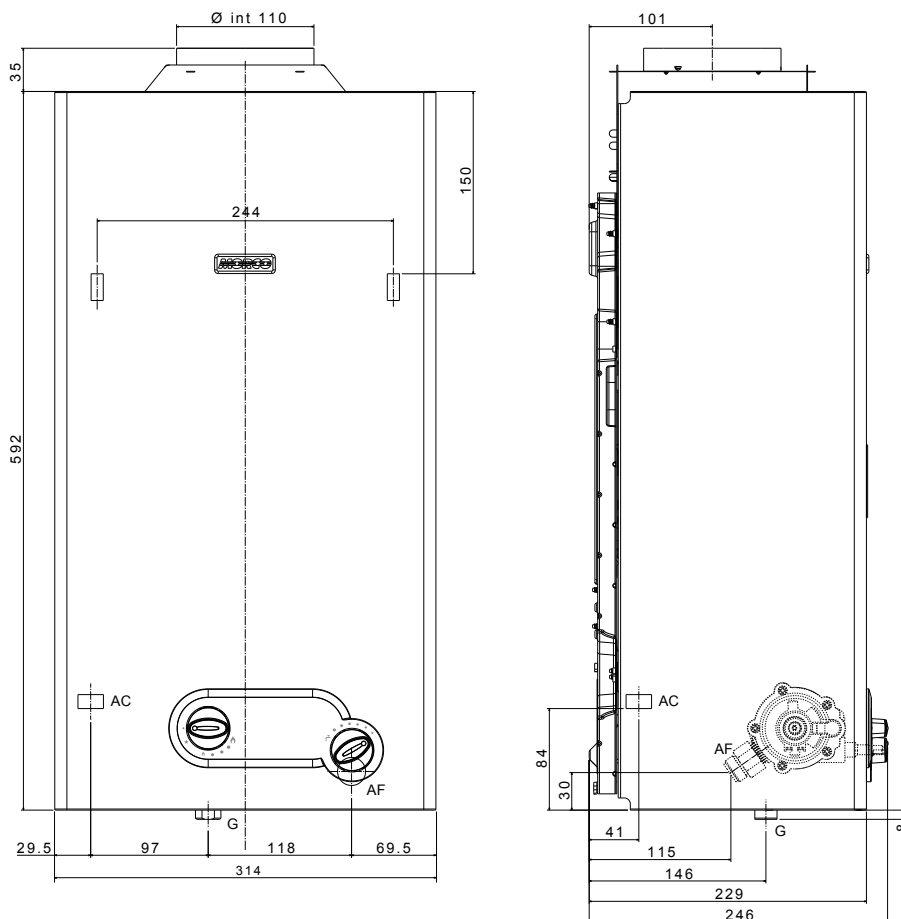

## 1.d Components

fig. 3

### EUP6

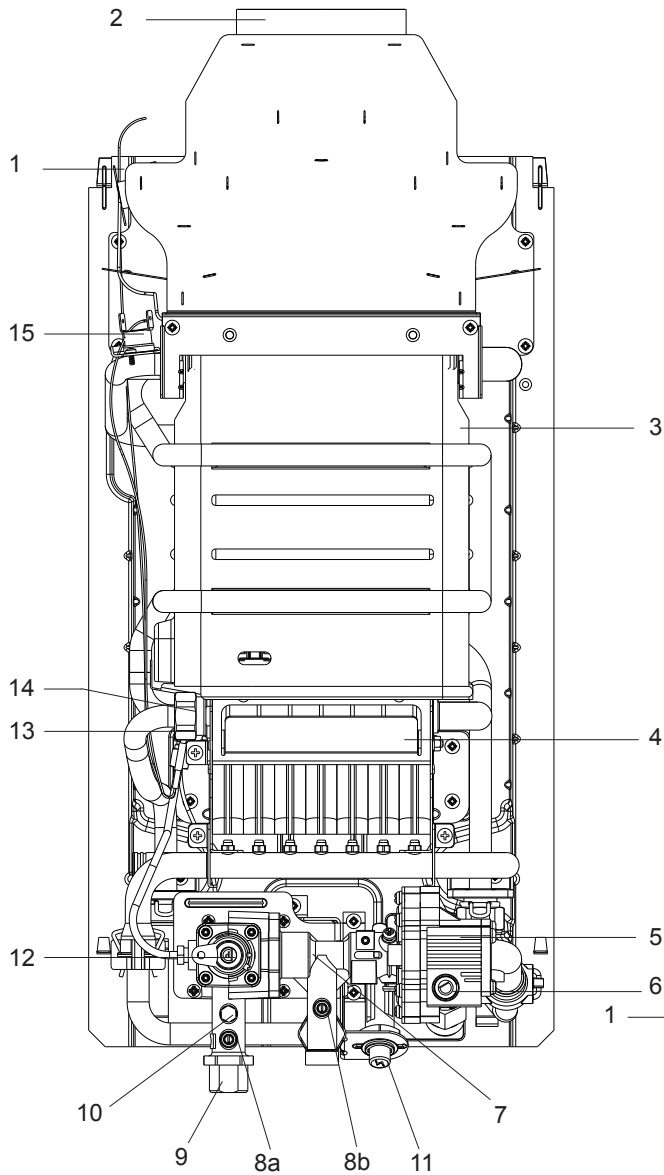

- 1 Combustion products safety sensor
- 2 Flue diverter hood
- 3 Heat exchanger
- 4 Burner
- 5 Water control assembly
- 6 Water temperature adjustment knob
- 7 Gas valve
- 8a Gas inlet test point
- 8b Burner pressure test point
- 9 Gas inlet
- 10 Gas adjustment screw - should not be adjusted
- 11 Piezoelectric pilot ignition button
- 12 Gas adjustment knob
- 13 Pilot burner
- 14 Ignition electrode
- 15 Hot water limit thermostat

### EUP11

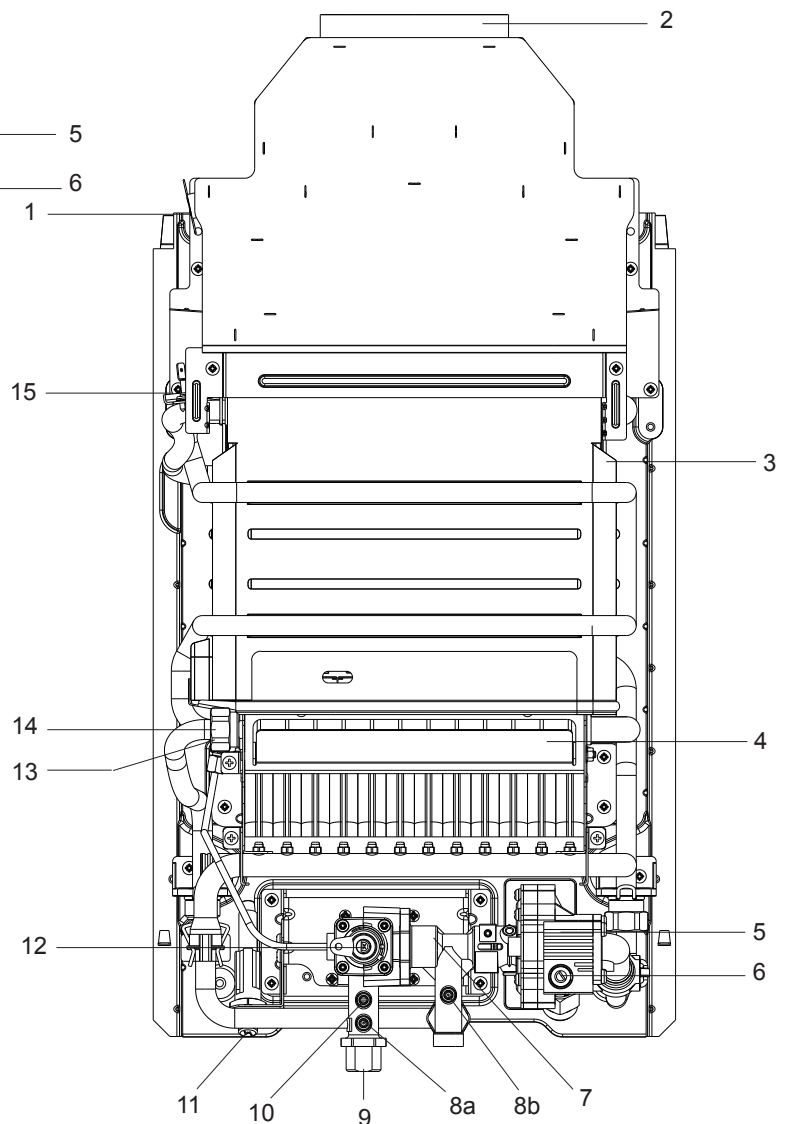

## 2. TECHNICAL CHARACTERISTICS

### 2.a Technical Data

		EUP6	EUP11	
		kW - kcal/h	kW - kcal/h	
Nominal power usage (Pn)		13,2 - 11.350	19,4 - 16.665	
Nominal Thermal range (Qn)		11,6 - 9.980	21,7 - 18.662	
Minimal power usage (Pm)		6,6 - 5.680	9,6 - 8.260	
Minimal Thermal range (Qm)		5,8 - 4.960	10,8 - 9.288	
GAS TYPE		PROPANE	BUTANE	PROPANE
		G31	G30	G31
P.C.I. (15° C 1013 mbar)	MJ/m <sup>3</sup>	88	116,09	88
WI (15° C 1013 mbar)	MJ/m <sup>3</sup>	70,69	80,58	70,69
Consumption	kg/h	1,03	1,71	1,69
Burner Pressure	mbar	32,0	26,60	35,80
Nr/Ø main burner injector	Nr/mm	14 x 0,5	18x0,48+6x0,50	
Ø pilot flame injector	mm	0,23	0,23	
Ø gas connection	inch	1/2"	1/2"	
Flue gas load (max-min)	g/s	12,48-10,29	11,80-9,75	12,48-10,29
Flue gas temperature (max-min)	°C	181-115	157-110	173-118

WATER		EUP6	EUP11	
Input range	l/min	Maximum 6 l/min	Minimum 5 l/min	Maximum 10.8 l/min
Water temperature lift	°C	approx. 25	approx. 50	approx. 25
Minimum pressure	bar	0,2	0,2	
Nominal pressure	bar	2	2	
Maximum pressure	bar	10	10	
Ø Water connections	inch	1/2"	1/2"	
Ø flue spigot diameter	mm	90	110	

DIMENSIONS AND WEIGHTS		DEVICE	PACKAGE	DEVICE	PACKAGE
Height	mm	550	632	592	675
Length	mm	255	303	314	361
Depth	mm	246	283	245	280
Weight	Kg	9,00	10,30	11,80	13,10

Note: relative cold water temperature of 15 °C



### 3. INSTALLATION

#### 3.a Regulations

The use of gas devices is controlled by precise regulations. Installation of liquefied petroleum gas (L.P.G.) must comply with all the manufacturer's requirements and those of the regulations in force.

#### 3.b Wall mounting

##### Warning

Do not install this device in an area that contains dust, greasy vapour and/or corrosive elements.

- The device must be installed on a suitable wall surface that allows the fitting of a vertical exhaust gas flue
- It is vital to leave the minimal distances around the device as shown in fig 4 to allow for maintenance operations to take place.

##### Location

The water heater requires a plentiful supply of fresh air for correct operation. Fixed ventilators or air inlets should not be obstructed. Do not install the water heater in a location where incomplete combustion is foreseeable such as bathrooms or bedrooms unless specifically allowed by national legislation.

The minimum low and high level free ventilation areas are stated on this page and must be observed.

The water heater must be fixed to a load bearing wall in a vertical plane.

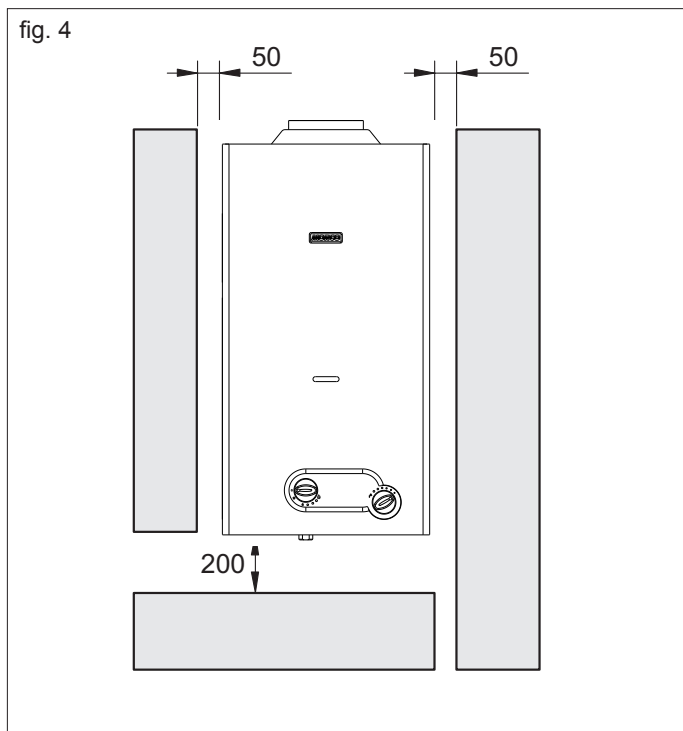

#### 3.c Room ventilation

The installation of the water heater must comply with regulations in force including any updates. See page 3

Warning: This device can only be installed in venues that are permanently ventilated according to regulation in force.

##### • COMBUSTION GAS REMOVAL

A single wall vertical flue pipe of Ø90 (for EUP6) and Ø110mm (for EUP11) must be used and when it passes through combustible materials, a metal sleeve of Ø170mm must be used to allow an air gap of 25 mm. Part codes FTFCT (for EUP6) and FTFCTRIMG101 (for EUP11).

Flue pipes and terminals should comply with BS 715. Terminals shall not be sited within 300 mm. of a ventilator or open window. In the U.K. full details of flueing requirements are given in BS EN 1949.

The overall length of the flue must be 600mm from the bottom of the terminal louvres to the top of the water heater. At least 250mm of this length must be external to the roof through which it is fitted.

##### • AIR SUPPLY FOR COMBUSTION

Air requirements: Reference is made to BS EN 1949 and EN 721 covering ventilation requirements for permanent dwellings, caravans and boats.

Fixed ventilation should be provided to avoid draughts as far as possible without impairing the free area of ventilation, even in adverse weather conditions. If the heater is positioned in location which may be subjected to strong draughts i.e. close to a window or opening then strong draughts or gusts of wind may extinguish the pilot.

All permanent openings for ventilation should be designed to prevent the entry of vermin. Where screens are provided, they should not have apertures of less than 6 mm. or greater than 9 mm. in any direction, and they should be accessible for cleaning. Fine mesh screens shall be avoided as they are liable to become blocked with dust.

The location of vents and the method of cleaning them should be stated in the Owners Handbook (Caravans and Boats).

As a guide, the minimum effective free area of vents is stated below in connection with this water heater. Additional appliances burning gas in the same area would require additional ventilation. If the appliance is installed in an enclosed cupboard in a Caravan Holiday Home the required ventilation is that specified in BS EN 1949, i.e. 10 cm<sup>2</sup> per kilowatt input rating divided between high and low.

#### 3.d Gas Connection

The water heater should be connected to the gas supply via a 15mm diameter copper gas pipe. A gas isolation valve must be fitted to the gas inlet on the water heater.

When installing or commissioning the water heater the following must be observed:

- The diameter of the gas pipe between the supply bottle or tank must be in accordance with the regulations in force
- The regulator size and pressure specification are correct for the application
- The correct gas (LPG) is being supplied
- All the required gas pressure and tightness tests are carried out as part of the commissioning process.
- Gas joints downstream of the magnetic gas valve must be checked with leak detection fluid while the heater is running
- Gas jointing paste **should not be used** when connecting the gas isolation valve

Do not obstruct the area's ventilation openings where the device is installed to avoid dangers such as the build-up of toxic and explosive gases.

**ATTENTION:** if the appliance is supplied with G31@50 mbar, remove the protective cap (pos. 10 water heater components pag. 7) and regulate the pressure screw so that the burner reaches the pressure indicate in the technical data.

### 3.e Water connection

Connect the water heater to the water supply.

From the front, the cold water input is on the right and the hot water output is on the left.

- ⚠ Insert the filter into the water valve input fitting.
- ⚠ Remove the plastic cap from the water outputs fitting before connecting it to the water supply.

fig. 5

#### SCHEMATIC DIAGRAM

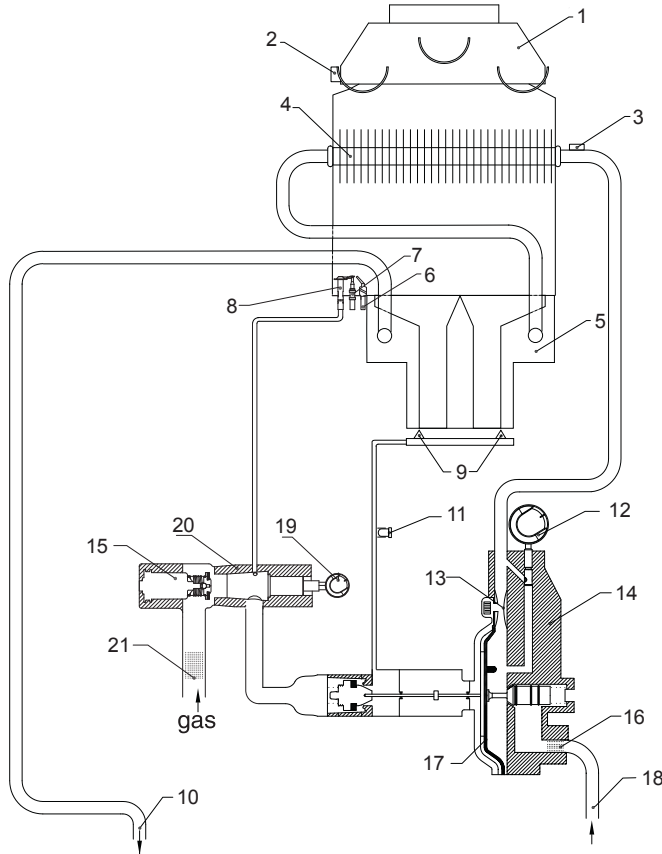

- 1 Flue diverter hood
- 2 Flue gas safety device
- 3 Hot water limit thermostat
- 4 Heat exchanger
- 5 Burner
- 6 Ignition electrode
- 7 Thermocouple
- 8 Pilot burner
- 9 Main burner injectors
- 10 Hot water output
- 11 Burner pressure test point
- 12 Water temperature selector knob
- 13 Venturi
- 14 Water control assembly
- 15 Magnetic valve
- 16 Water filter
- 17 Diaphragm
- 18 Cold water input
- 19 Gas adjustment knob
- 20 Gas valve

### 3.f Flue Gas

For output of flue gases refer to the regulations in force including any updates. See page 3.

The water heater must be connected to a suitable flue terminal. The following must be observed:

- The flue must be installed vertically – through the roof of the holiday home
- The diameter of the flue terminal must match that of the water heater (90 mm for EUP6 and 110mm for EUP11)
- The overall flue length from the top of the water heater to the top of the external flue must be at least 600mm. The distance from the external roof surface to the top of the external flue must be at least at least 250mm.

#### Flue gas safety device

This product is equipped with a flue gas safety device. The device ensures the flue gases leave the water heater safely via the flue. The flue safety device marked as 2 in Fig.6 is a flue gas safety device that will interrupt the flow of gas to the water heater burner and pilot light in the event that there is a total or partial blockage in the flue that does not allow the flue gases to leave safely. The device will also operate if the design or length of the flue is not correct. This stat will reset when it has cooled down due to the technical issue being resolved thus allowing the water heater to operate as normal.

If the flue gas safety device is faulty it will need to be replaced before the water heater will function again. The stat must not be removed or altered in any way otherwise the operation of the water heater may become dangerous.

## 4. MAINTENANCE

To maintain the machine at maximum efficiency, have a Gas Safe Engineer or other qualified personnel perform a maintenance check at least once a year.

Before cleaning or performing maintenance, opening or disassembling the panels, switch off the device and turn off the gas supply. Check the main burner and the pilot flame, the ignition electrode, the safety valve and that there is no gas or water leakage. Check that there is nothing obstructing the passages within the heat exchanger or flue.

To clean the outside of the panels utilize a cloth with soap and water. Do not use solvents, powders or abrasive sponges.

Do not clean the device and/or its parts with flammable materials (e.g. petrol, alcohol, diesel etc.).

### 4.a Removing the casing

To remove the outer casing follow the steps below:

- Remove the selector knobs (A and B)
- Remove the screws (C)
- Pull the bottom of the casing forwards until clear of the gas/water spindles
- Shift the casing upwards to free it from the upper and lateral hooks
- Shift the casing forwards
- To reinsert the casing, follow the above steps in reverse order.

### 4.b Troubleshooting: problems and solutions

For the best functioning of the water heater, to prolong its lifetime and ensure that it is always safe, it should be inspected at least once a year by a gas safe engineer. The gas safe engineer is to perform the following maintenance operations:

- Remove any rust from the burner
- Remove any deposit from the electrodes
- Clean the combustion chamber
- Check the ignition, switching off and general functionality of the appliance
- Check that the gas and water pipes and connections are sealed

Warning: the following repair instructions are only to be performed by Gas Safe Engineers or other qualified personnel.

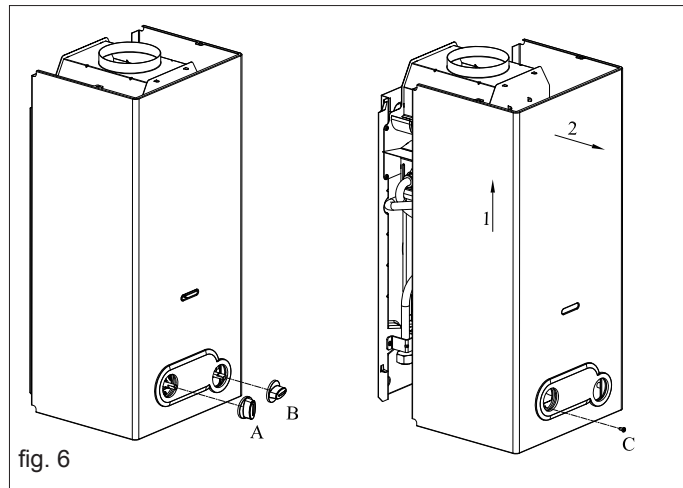

PROBLEM	CAUSE	SOLUTIONS
There is no spark	<ul style="list-style-type: none"> <li>- appliance spark wire is disconnected</li> <li>- piezoelectric mechanism broken</li> <li>- the electrode is damaged</li> </ul>	<ul style="list-style-type: none"> <li>- reconnect</li> <li>- test, replace</li> <li>- replace</li> </ul>
The pilot does not switch on when there is a spark	<ul style="list-style-type: none"> <li>- pilot injector blocked</li> <li>- electrode activation position needs changing</li> <li>- no gas supply</li> <li>- air in the gas tubes</li> </ul>	<ul style="list-style-type: none"> <li>- clean by immersing in solvent or replace</li> <li>- adjust</li> <li>- open the appliance gas isolation valve</li> <li>- purge air by turning on all gas rings on hob for 30 seconds</li> </ul>
The pilot does not stay on	<ul style="list-style-type: none"> <li>- thermocouple faulty</li> <li>- broken magnetic valve</li> <li>- flue sensor faulty or activated</li> </ul>	<ul style="list-style-type: none"> <li>- replace</li> <li>- replace</li> <li>- check flueing/ventilation</li> <li>- replace</li> </ul>
Pilot on but the main burner does not ignite	<ul style="list-style-type: none"> <li>- insufficient water pressure</li> <li>- the diaphragm is broken</li> </ul>	<ul style="list-style-type: none"> <li>- Increase the external water supply pressure</li> <li>- rotate the knob B counter clockwise</li> <li>- replace</li> </ul>
The burner does not switch off when the water turns off	<ul style="list-style-type: none"> <li>- contamination on the gas valve seat</li> <li>- gas valve push rod is locked in the open position</li> <li>- check the gas pressure</li> </ul>	<ul style="list-style-type: none"> <li>- test, clean</li> <li>- Check the correct operation of the cold water push rod, dis-assemble, clean or replace</li> <li>- if the inlet gas pressure exceeds the specification replace the pressure regulator on the external bottle or tank</li> </ul>
Delayed burner activation	<ul style="list-style-type: none"> <li>- pilot burner flame is too far from main burner flame or it is too short</li> </ul>	<ul style="list-style-type: none"> <li>- check inlet gas pressure, clean injector and pilot burner</li> </ul>
The heat exchanger fins becomes sooty in a small amount of time	<ul style="list-style-type: none"> <li>- poor draught, adverse weather conditions or dusty surroundings</li> <li>- yellow flame</li> <li>- excess gas consumption</li> </ul>	<ul style="list-style-type: none"> <li>- check the flue installation</li> <li>- check the gas type and clean the burner</li> <li>- check gas pressure and adjust</li> </ul>

# **FOR THE ENGINEER**

## **STARTING UP THE APPLIANCE AND FINAL CHECKS**

Start the appliance by following the directions given in section 1b, "Usage", checking that the appliance is working correctly. Pay special attention to the colour of the flames ensuring there is no yellow-ness which would indicate burner venturis blocked by insect matter.

Check the gas operating pressures with the heater under full power at the inlet pressure nipple located on the right hand side of the gas body valve stem.

Check the burner pressure with the heater at full load at the test nipple located on the left hand side of the main gas valve body below the main burner. These pressures must at least be equal those specified in this manual in order to achieve the desired performance specified in this manual.

These gas water heaters are set in the factory for use with the gas they are intended to burn. The gas for which each appliance is set is indicated on the packaging and on the data plate of the heater itself

Check the flue for spillage: close all the doors and windows in the room containing the water heater. If there are any fans or extractors in the room then these must be turned on full. Light any other open flued appliances such as fires or gas hobs. Turn the water heater on by opening a hot tap on full burn and run for 5 minutes to allow the flue to warm up.

Hold a smoke match to the side of the opening of the draught diverter using an extended holder, making sure that the end of the match is located centrally in the draught diverter.

The smoke should be pulled up the flue and not back into the room. If spillage is detected, run the appliance for a further 10 minutes and then repeat the test. If spillage is still detected then check the flue for blockages, check that the correct flue terminal is fitted and that the correct ventilation is fitted at a low and high level. Also check the ventilation has not been blocked.

### **A.2.3. - LOOKING AFTER THE APPLIANCE**

#### **• PRECAUTIONS**

##### **– Against furring up (lime scale)**

If the appliance is installed in an area with very hard water, with time, the following may occur:

- A fall in the hot water temperature, or
- A reduction in the hot water flow.

This means that the heat exchanger may be furred up, creating the above situations

Note: De-furring/descaling should be carried out using proprietary agent or dilute hydrochloric acid. It is recommended to circulate the descaling fluid around the heat exchanger in order to speed up the process.

#### **• MINIMUM ANNUAL MAINTENANCE**

Gas water heaters are rugged pieces of equipment which are designed to work for a long time with minimum maintenance requirements. The only regular maintenance required is the (annual) cleaning of the heating body and the burner. If the appliance is installed in a caravan it is advised that this is done at the beginning of each season.

#### **• CLEANING THE MAIN BURNER**

To carry out the annual cleaning of the burner, proceed as follows:

- Turn off the gas supply, remove the cover and remove the burner.
- Clean the surface of the burner heads gently with a brush and vacuum cleaner. Then blow through them to remove any particles of dust loosened during the brushing operation.
- Check the venturis in the main burner for contamination from

insects and spiders webs.

#### **• CLEANING THE HEAT EXCHANGER**

To carry out the annual cleaning of the heating body, proceed as follows:

- Turn off the gas supply
- Turn off the supply of water to the appliance by turning off the appliance water supply.
- Turn on all the hot water taps to empty all the pipes.
- Remove the heating body and clean it by gently brushing the fins. Soot, if found, should be removed by washing, and the cause of the sooting investigated.

#### **• CLEANING THE PILOT**

If the pilot light flame is yellow and the safety valve takes a long time to open, this means that either the pilot injector or pilot burner is partially blocked.

The pilot injector may be blocked with contaminants carried within the gas, whilst the pilot burner is more likely to be contaminated by insects (spiders / egg sacs)

N.B. No attempt should be made to clear blocked or partially blocked pilot injectors by using wire. If blowing through the injector or immersing in solvent fails to clear the restriction, then a new injector should be fitted.

When the pilot is working normally the flame should be a stable blue coloured cone shape. To clean the pilot burner, proceed as follows:

- Turn off the gas supply, remove the front cover. Remove the pilot injector, by slackening the supply pipe nut first, and unscrewing the pilot injector from the pilot burner
- Remove the contamination from within the pilot burner using a pipe cleaner, and blow through to remove any further debris.
- Replace the pilot injector, ensuring that the washers are properly fitted.

# WINTERISATION

## Winterisation of Holiday Homes That Have a Water Heater

Fresh water freezes at 0°C and expands by 9% with a significant force that will destroy:

- Pipe work
- Water heater components
- Taps, and shower valves

## DRAIN DOWN

If you leave fresh water in your caravan system over the winter you will run the risk of damage. This can only be avoided by removing the fresh water from the system – we call this a “drain down”. You may wish to drain down the fresh water system yourself using the procedure in the next section but we STRONGLY RECOMMEND that you have this carried out by an experienced engineer as many caravan systems can only be completely drained by blowing the water out and this requires specialist equipment. View the charge for a drain down as a mini insurance policy and always ask the engineer if he has the equipment to blow the water out. The two most common parts to be damaged by frost on a water heater are the water control assembly and heat exchanger and the shower valve can also be damaged by frost and the costs to replace these can be expensive, see our website for water heater spare prices.

## Drain Down Procedure – without specialist equipment

- Turn off the fresh water supply stop cock outside the Holiday Home
- Disconnect the fresh water feed outside the home if possible as this protects from flooding due to stop cock failure
- Open all hot and cold taps and shower valves and place the shower head in the tray
- Use the Holiday Home Owner’s Handbook to locate all the fresh water drain cocks under the van – some of these may not be obvious
- Open these drain cocks

This procedure does not guarantee that all the fresh water will leave the system. Most modern homes have double check valves in the TMV2 shower mixers and these trap fresh water and stop the flow of water around the system once the drain cocks and taps are open. It may appear that all the water has left the system, but beware! This pitfall can be avoided by removing the shower mixer valve/valves from the system after the cold water supply has been switched off and the drain cocks opened. Many manufacturers provide access panels and these may make the removal of shower mixers easier. Removal of some shower mixers requires the use of special tools.

In addition, pipe work layouts can cause air locks leaving water inside vulnerable components such as the water heater or shower mixer.

Re-commissioning the home is a reverse of the above procedure.

This drain down procedure may work but the only way to be sure is to blow the water out using compressed air at 3 bar maximum pressure.

## **WARRANTY**

The water heater is guaranteed against manufacturing defects for one year from first commissioning date. However the guarantee is subject to proof of commissioning in accordance with the gas safety (Installation and Use) act of 1998. The guarantee does not cover defects caused by lack of maintenance.

Morco Products Ltd. warranty will cover parts and labour if the appliance has been fitted as part of the original equipment in a caravan holiday home or leisure accommodation vehicle.

Appliances distributed as non original equipment either directly from Morco Products Ltd. or other merchants are subject to a return to base policy for repair and return.

As an alternative to returning the appliance for repair we will supply spare parts and advice for defective appliances on the provision that we can talk to the competent registered gas safe engineer involved in the fitting or repair of the defective appliance. Under this approach, no compensation will be offered for labour involved in the removal and refitting of the appliance or for any work / travelling involved in the fitting of spare parts.

### Exclusions from warranty

- Damage caused by frost
- Scaling up of the heat exchanger
- Blocked pilot injectors
- Insect or debris in the burner or heat exchanger
- Blocked gas or water filters
- Incorrect operation caused by damaged mixer taps or shower TMV2
- Incorrect installation of the appliance or flue
- Low water pressure

**Please note that proof of commissioning for the purposes of this warranty is a copy of the commissioning certificate as filled out by the Gas Safe Engineer or other qualified personnel.**





Supplied by Innovita Italy

Distributed in U.K. by:  
**MORCO PRODUCTS LTD**

Morco House  
Riverview Road  
Beverley  
East Yorkshire  
HU17 0LD  
ENGLAND

Telephone Number: 01482 325456  
Fax Number: 01482 212869  
Web Address: [www.morcoproducts.co.uk](http://www.morcoproducts.co.uk)