



REGISTER YOUR PRODUCT ONLINE



TAKEYOURGENERATOROUTSIDE.COM

**SAVE THESE INSTRUCTIONS.** This manual contains important safety precautions which should be read and understood before operating the product. Failure to do so could result in serious injury. This manual should remain with the product.

Specifications, descriptions and illustrations in this manual are as accurate as known at the time of publication, but are subject to change without notice.

Covered by one or more of the following U.S. Patent Numbers: 10,862,414 and other U.S. and foreign patents pending.

**TAKE IT  
OUTSIDE™**



**CARBON MONOXIDE KILLS**

## CARBON MONOXIDE SAFETY: THE BIG PICTURE

As the only safe way to use a portable generator, taking your generator outside is absolutely mandatory to keep your family safe from carbon monoxide. But there's even more you can do. By educating yourself about all carbon monoxide risks, you'll be better prepared to protect your family from this colorless, odorless threat.



**ALWAYS READ  
THE OPERATOR'S  
MANUAL FIRST**



### KNOW THE SYMPTOMS

- Headache
- Nausea
- Shortness of breath
- Dizziness
- Fatigue

**STAY ALERT WITH CARBON  
MONOXIDE DETECTORS**

**KEEP IT OUTSIDE AND AWAY FROM  
DOORS, WINDOWS, AND GARAGES**

**IF YOU FEEL SYMPTOMS,  
LEAVE RIGHT AWAY**

**POINT FUMES AWAY FROM  
NEARBY PEOPLE**

[www.TakeYourGeneratorOutside.com](http://www.TakeYourGeneratorOutside.com)

## TABLE OF CONTENTS

<b>Introduction</b> .....	<b>5</b>	Moving the Generator .....	32
<b>Safety Definitions</b> .....	<b>5</b>	Operation at High Altitude .....	32
<b>Important Safety Instructions</b> .....	<b>6</b>	<b>Maintenance</b> .....	<b>33</b>
Fuel Safety .....	8	Cleaning the Generator .....	33
Safety and Dataplate Labels .....	9	Changing the Engine Oil .....	33
Safety Symbols .....	10	Cleaning and Adjusting the Spark Plug .....	34
Operation Symbols .....	11	Cleaning the Air Filter .....	35
Quick Start Label Symbols .....	12	Cleaning the Spark Arrestor .....	35
<b>Controls and Features</b> .....	<b>13</b>	Adjusting the Governor .....	35
Generator .....	13	Generator Battery .....	36
Control Panel .....	14	Remote Key Fob Transmitter Battery .....	36
Fuel Dial .....	14	Maintenance Schedule .....	37
Intelligauge with CO Shield® .....	15	<b>Storage</b> .....	<b>37</b>
Wireless Remote Control .....	16	Short to Mid Term Storage (up to 1 year) .....	37
Parts Included .....	16	Long Term Storage (more than 1 year) .....	37
Tools Needed .....	16	Removing from Storage .....	38
Tools Included .....	16	<b>Specifications</b> .....	<b>39</b>
<b>Assembly</b> .....	<b>17</b>	Generator Specifications .....	39
Unpacking .....	17	Engine Specifications .....	39
Remove Shipping Support Hardware .....	17	Oil Specifications .....	39
Install the Wheel Kit .....	17	Fuel Specifications .....	39
Connect the Battery .....	18	Battery Specifications .....	39
Add Engine Oil .....	18	Temperature Specifications .....	39
Add Fuel .....	19	Figure A Parts Diagram .....	40
Grounding .....	20	Figure A Part List .....	41
<b>Operation</b> .....	<b>21</b>	Figure B Engine Parts Diagram .....	43
CO Shield® - Carbon Monoxide (CO) Detection and Auto-shutoff System .....	21	Figure B Engine Part List .....	44
Generator Location .....	22	Figure C Parts Diagram .....	45
Wireless Set Button .....	23	Figure C Part List .....	46
Surge Protection .....	24	Figure D Parts Diagram .....	47
Starting the Engine: No ATS or ATS on Manual Mode .....	24	Figure D Part List .....	48
Starting the Engine: ATS on Automatic Mode .....	26	Figure E Parts Diagram .....	49
Battery .....	28	Figure E Part List .....	50
Connecting Electrical Loads .....	28	Figure F Parts Diagram .....	51
Do Not Overload Generator .....	28	Figure F Part List .....	52
Box System ATS User Manual .....	29	Figure G Parts Diagram .....	53
Eco (Economy) Mode .....	30	Figure G Part List .....	54
12V DC Regulated Automotive Style Outlet .....	30	Wiring Diagram .....	55
Stopping the Engine: No ATS or ATS on Manual Mode .....	31		
Stopping the Engine: ATS on Automatic Mode .....	32		

**Troubleshooting** ..... **56**

**WARRANTY\*** ..... **59**

    Warranty Qualifications ..... 59

    Repair/Replacement Warranty ..... 59

    Do Not Return The Unit To The Place Of Purchase ..... 59

    Warranty Exclusions ..... 59

    Other Exclusions ..... 59

    Limits of Implied Warranty and Consequential Damage ..... 59

    Contact Information ..... 59



# INTRODUCTION

Congratulations on your purchase of a Champion Power Equipment (CPE) product. CPE designs, builds, and supports all of our products to strict specifications and guidelines. With proper product knowledge, safe use, and regular maintenance, this product should bring years of satisfying service.

Every effort has been made to ensure the accuracy and completeness of the information in this manual at the time of publication, and we reserve the right to change, alter and/or improve the product and this document at any time without prior notice.

CPE highly values how our products are designed, manufactured, operated, and serviced as well as providing safety to the operator and those around the generator. Therefore, it is IMPORTANT to review this product manual and other product materials thoroughly and be fully aware and knowledgeable of the assembly, operation, dangers and maintenance of the product before use. Fully familiarize yourself, and make sure others who plan on operating the product fully familiarize themselves too, with the proper safety and operation procedures before each use. Please always exercise common sense and always err on the side of caution when operating the product to ensure no accident, property damage, or injury occurs. We want you to continue to use and be satisfied with your CPE product for years to come.

When contacting CPE about parts and/or service, you will need to supply the complete model and serial numbers of your product. Transcribe the information found on your product's nameplate label to the table below

<b>CPE TECHNICAL SUPPORT TEAM</b>
<b>MODEL NUMBER</b>
97001i-P-UK
<b>SERIAL NUMBER</b>
<b>DATE OF PURCHASE</b>
<b>PURCHASE LOCATION</b>

# SAFETY DEFINITIONS

The purpose of safety symbols is to attract your attention to possible dangers. The safety symbols, and their explanations, deserve your careful attention and understanding. The safety warnings do not by themselves eliminate any danger. The instructions or warnings they give are not substitutes for proper accident prevention measures.

## **DANGER**

DANGER indicates a hazardous situation which, if not avoided, will result in death or serious injury.

## **WARNING**

WARNING indicates a hazardous situation which, if not avoided, could result in death or serious injury.

## **CAUTION**

CAUTION indicates a hazardous situation which, if not avoided, could result in minor or moderate injury.

## **NOTICE**

NOTICE indicates information considered important, but not hazard-related (e.g., messages relating to property damage).

# IMPORTANT SAFETY INSTRUCTIONS

## ⚠ DANGER

Generator exhaust contains carbon monoxide, a colourless, odorless, poisonous gas. Breathing carbon monoxide will cause nausea, dizziness, fainting or death. If you start to feel dizzy or weak, get to fresh air immediately.

### OPERATE GENERATOR OUTDOORS ONLY IN A WELL VENTILATED AREA AND POINT EXHAUST AWAY.

DO NOT operate the generator inside building, including garages, basements, crawlspaces, sheds or enclosure or compartment, vehicles and(or) including the generator compartment of a recreational vehicle.

DO NOT allow exhaust fumes to enter a confined area through windows, doors, vents or other openings.

## ⚠ DANGER

Using a generator indoors **CAN KILL YOU IN MINUTES**. Generator exhaust contains carbon monoxide. This is a poison you cannot see or smell.

**NEVER** use inside a home or garage, or any out buildings, **EVEN IF** doors and windows are open.

**ONLY** use **OUTSIDE** and far away from windows, doors, and vents.

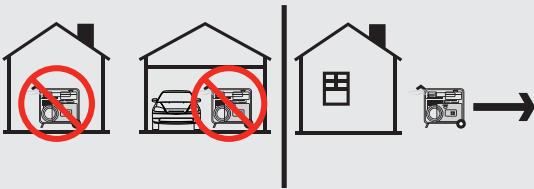

Install battery-operated carbon monoxide alarms or plug-in carbon monoxide alarms with battery back-up according to the manufacturer's instructions.

## ⚠ DANGER

Tampering with the CO Shield® system will result in a hazardous condition and will void your warranty.

Removing the CO Shield® module will not allow the generator to start.

## ⚠ DANGER

Operate equipment with guards in place.

Rotating parts can entangle hands, feet, hair, clothing and/or accessories. Traumatic amputation or severe laceration can result.

Keep hands and feet away from rotating parts.

Tie up long hair and remove jewelry.

DO NOT wear loose-fitting clothing, dangling drawstrings or items that could become caught.

## ⚠ DANGER

Generator produces powerful voltage.

DO NOT touch bare wires or live sockets.

DO NOT use electrical cords that are worn, damaged or frayed. Use only Champion electrical cords for proper application.

DO NOT operate generator in wet weather including rain or snow.

DO NOT allow children or unqualified persons to operate or service the generator.

Use a ground fault circuit interrupter (GFCI) in damp areas and areas containing conductive material such as metal decking.

Connection to your home's electrical system requires a listed 100A transfer switch installed by a licensed electrician and approved by the local authority having jurisdiction. The connection must isolate the generator from the utility power and must comply with all applicable laws and electrical codes.

## ⚠ WARNING

Do not use generator for medical and life support uses.

In case of emergency, emergency services immediately.

NEVER use this product to power life support devices or life support appliances.

NEVER use this product to power medical devices or medical appliances.

Inform your electricity provider immediately if you or anyone in your household depends on electrical equipment to live.

Inform your electrical provider immediately if a loss of power would cause you or anyone in your household to experience a medical emergency.

**⚠ WARNING**

Spark from removed spark plug wire can result in fire or electrical shock.

**When servicing the generator:**

Disconnect the spark plug wire and place it where it cannot contact the plug or any other metal object.

DO NOT check for spark with the plug removed.

Use only approved spark plug testers.

**⚠ WARNING**

Running engines produce heat. Severe burns can occur on contact. Combustible material can catch fire on contact.

DO NOT touch hot surfaces like engine or muffler/exhaust, always allow to cool for minimum 30mins.

Avoid contact with hot exhaust gases and allow to cool min 30 mins.

Allow equipment to cool min 30 mins before touching or handling.

Maintain at least 3 ft. (91.4 cm) of clearance on all sides to ensure adequate cooling.

Maintain at least 5 ft. (1.5 m) of clearance from combustible materials.

**⚠ WARNING**

Rapid retraction of the recoil cord will pull hand and arm towards the engine faster than you can let go. Broken bones, fractures, bruises or sprains could result. Unintentional startup can result in entanglement, traumatic amputation or laceration.

**⚠ CAUTION**

When starting the engine, pull the recoil cord slowly until resistance is felt, release cord back and use one strong rapid pull to start, this avoids any kickback or damage to the recoil assembly. Rigorously pulling will result in damage to the recoil assembly and void any warranty.

**⚠ WARNING**

Although the generator contains a spark arrester, maintain a minimum distance of 5 ft. (1.5 m) from dry vegetation to prevent fires.

**⚠ CAUTION**

Exceeding the generator's running capacity can damage the generator and/or electrical devices connected to it.

DO NOT overload the generator.

DO NOT tamper with the governed speed.

DO NOT modify the generator in any way.

Do Not install or modify the exhaust/muffler with any extension or extraction, by doing so will void any warranty offered

**⚠ CAUTION**

Start the generator and allow the engine to stabilize before connecting electrical loads.

Connect electrical equipment in the off position, and then turn them on for operation.

Turn electrical equipment off and disconnect before stopping the generator.

**⚠ CAUTION**

Improper treatment or use of the generator can damage it, shorten its life or void the warranty.

Use the generator only for intended uses.

Operate only on Flat level surfaces.

DO NOT expose generator to excessive moisture, dust, or dirt.

DO NOT allow any material to block the cooling slots.

If connected devices overheat, turn them off and disconnect them from the generator.

**DO NOT use the generator if:**

- Electrical output is lost
- Equipment sparks, smokes or emits flames
- Equipment vibrates excessively

## Fuel Safety

### DANGER

**PETROL AND PETROL VAPORS ARE HIGHLY FLAMMABLE AND EXPLOSIVE.**

Fire or explosion can cause severe burns or death.

#### **Petrol and petrol vapors:**

- Petrol is highly flammable and explosive.
- Petrol can cause a fire or explosion if ignited.
- Petrol is a liquid fuel but it's vapors can ignite.
- Petrol is a skin irritant and needs to be cleaned up immediately if spilled on skin or clothes.
- Petrol has a distinctive odor, this will help detect potential leaks quickly.
- Petrol expands or contracts with ambient temperatures. Never fill the fuel tank to full capacity, as petrol needs room to expand when temperatures rise.
- In the case of any petroleum petrol fire, flames should never be extinguished unless the fuel supply valve can be turned OFF. By not doing so, if a fire is extinguished and the supply of fuel is not turned OFF, an explosion hazard could be created.

#### **When adding or removing petrol:**

DO NOT light or smoke cigarettes.

Turn the generator off and let cool for at least two minutes before removing the fuel cap. Always loosen the cap slowly to relieve pressure in the tank.

Only fill or drain petrol outdoors in a well-ventilated area.

DO NOT pump petrol directly into the generator at the filling station. Always use an approved container to transfer the fuel to the generator.

DO NOT overfill the fuel tank.

Always keep petrol away from sparks, open flames, pilot lights, heat and other sources of ignition.

#### **When starting the generator:**

DO NOT attempt to start a damaged generator.

Always check that the fuel cap, air filter, spark plug, fuel lines and exhaust system are properly in place.

Always allow spilled petrol to evaporate fully before attempting to start the engine.

Always be certain that the generator is resting firmly on flat level ground.

#### **When operating the generator:**

DO NOT move, angle or tip the generator during operation.

#### **When transporting or servicing the generator:**

Always check that the fuel valve is in the OFF position and the fuel tank is empty.

Disconnect the spark plug wire.

#### **When storing the generator:**

Store away from sparks, open flames, pilot lights, heat and other sources of ignition.

Do not store generator or petrol near furnaces, water heaters, or any other appliances that produce heat or have automatic ignitions.

### DANGER

NEVER place a petrol container, petrol tank, LPG cylinder or any combustible material in the path of the exhaust stream during operation of the engine.

### WARNING

Never use a petrol container, fuel tank, or any other fuel item that is broken, cut, torn or damaged.

Safety and Dataplate Labels

These labels warn you of potential hazards that can cause serious injury. Read them carefully.

If a label comes off or becomes hard to read, contact Technical Support Team for possible replacement.

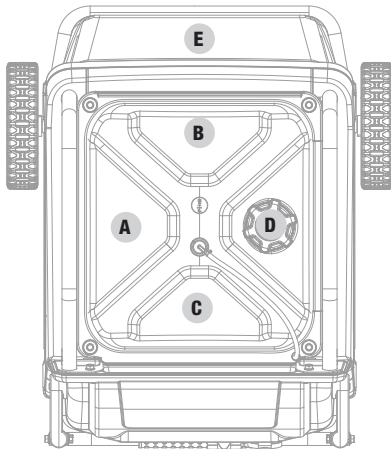

Top

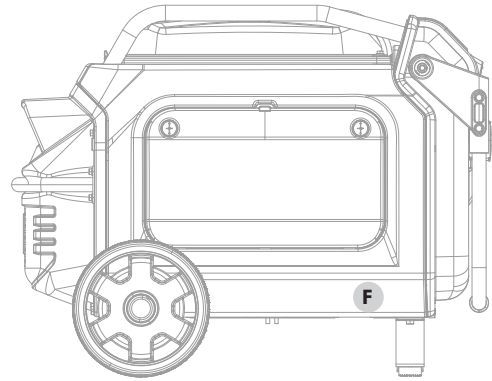









Back

	LABEL	DESCRIPTION									
A		CO Danger									
B		Safety Symbols									
C		CO Shield® Action – automatic shutoff *See CO Shield® section									
D		Fuel									
E		Hot Surface									
F	<table border="1"> <tr> <td colspan="2"> <b>CHAMPION POWER EQUIPMENT, INC.</b>                      12039 SMITH AVENUE                      SANTA FE SPRINGS, CA 90670                      USA / E.-U.                      MADE IN CHINA                      Low Power Generating Set                 </td> <td> <b>UK CA</b> </td> <td>                     FREQUENCY (Hz) <b>50</b>                      RPM <b>3600</b>                      PHASE <b>1</b>                      POWER FACTOR <b>1.0</b>                      RATED VOLTAGE <b>240V/50Hz</b>                      AC AMPS <b>29.2A</b>                      Performance Class <b>G2</b> </td> <td>                     Net Weight <b>96.5kg</b>                      Quality Class <b>A</b>                      MAX AMBIENT TEMP <b>104°F/40°C</b>                      INSULATION CLASS <b>F</b>                      Rated Output <b>COP-7 kW</b>                      Max Power <b>7.45kW S2 8min</b> </td> </tr> <tr> <td>                     MODEL <b>97001i-P-UK</b>                      SERIAL NO. <b>XXXXXXXXXXXX</b>                      Year of Manufacture <b>XXXX</b>                      IP Grade <b>IP23M</b> </td> <td colspan="3"></td> </tr> </table>	<b>CHAMPION POWER EQUIPMENT, INC.</b> 12039 SMITH AVENUE SANTA FE SPRINGS, CA 90670 USA / E.-U. MADE IN CHINA Low Power Generating Set		<b>UK CA</b>	FREQUENCY (Hz) <b>50</b> RPM <b>3600</b> PHASE <b>1</b> POWER FACTOR <b>1.0</b> RATED VOLTAGE <b>240V/50Hz</b> AC AMPS <b>29.2A</b> Performance Class <b>G2</b>	Net Weight <b>96.5kg</b> Quality Class <b>A</b> MAX AMBIENT TEMP <b>104°F/40°C</b> INSULATION CLASS <b>F</b> Rated Output <b>COP-7 kW</b> Max Power <b>7.45kW S2 8min</b>	MODEL <b>97001i-P-UK</b> SERIAL NO. <b>XXXXXXXXXXXX</b> Year of Manufacture <b>XXXX</b> IP Grade <b>IP23M</b>				Dataplate
<b>CHAMPION POWER EQUIPMENT, INC.</b> 12039 SMITH AVENUE SANTA FE SPRINGS, CA 90670 USA / E.-U. MADE IN CHINA Low Power Generating Set		<b>UK CA</b>	FREQUENCY (Hz) <b>50</b> RPM <b>3600</b> PHASE <b>1</b> POWER FACTOR <b>1.0</b> RATED VOLTAGE <b>240V/50Hz</b> AC AMPS <b>29.2A</b> Performance Class <b>G2</b>	Net Weight <b>96.5kg</b> Quality Class <b>A</b> MAX AMBIENT TEMP <b>104°F/40°C</b> INSULATION CLASS <b>F</b> Rated Output <b>COP-7 kW</b> Max Power <b>7.45kW S2 8min</b>							
MODEL <b>97001i-P-UK</b> SERIAL NO. <b>XXXXXXXXXXXX</b> Year of Manufacture <b>XXXX</b> IP Grade <b>IP23M</b>											











## Safety Symbols









Some of the following symbols may be used on this product. Please study them and learn their meaning. Proper interpretation of these symbols will allow you to more safely operate the product.

SYMBOL	MEANING
	<b>Caution.</b>
	<b>Read The Operator's Instruction Manual Before Use.</b> To reduce the risk of injury, user must read and understand operator's manual before using this product.
	<b>Not For General Waste Disposal.</b>
	The generating set must not be connected to other power sources, such as the power company supply mains.
	<b>Electric Hazard.</b> Failure to use in dry conditions and to observe safe practices can result in electric shock. Improper connections to a building can allow current to backfeed into utility lines, creating an electrocution hazard. A transfer switch must be used when connecting to a building.
	<b>Fire Hazard.</b> Fuel and its vapors are extremely flammable and explosive. Fire or explosion can cause severe burns or death. Keep generator at least 5 feet (1.5m) from all objects to prevent combustion.
	<b>Risk Of Being Burnt.</b> To reduce the risk of injury or damage, avoid contact with any hot surface.
	<b>Carbon Monoxide(co) Danger.</b>
	<b>Wet Conditions Alert.</b> Do not expose to rain or use in damp locations except as follows: If you must operate in rain or damp locations, DO NOT operate without proper protection of the electrical components. Use of a safety canopy that is fire retardant and will provide proper air ventilation for the engines exhaust stream can be used. Keep all objects a minimum of 5 feet (1.5m) away from the generator at all times. Heat from the muffler surface and exhaust stream can ignite combustible materials.

## Operation Symbols

Some of the following symbols may be used on this product. Please study them and learn their meaning. Proper interpretation of these symbols will allow you to more safely operate the product.

SYMBOL	MEANING
	Start
	Run
	Fuel Valve Off
	Stop
	Choke
	Overload Reset Button
	Low Oil
	Economy Mode Button
	Circuit Breaker Reset: Push
	Ground Terminal

SYMBOL	MEANING
	12V Direct Current
	Battery Connector
	Wireless Pair
	<b>Neutral Floating.</b> Neutral circuit <b>IS NOT</b> electrically connected to the frame/ground of the generator.
	<b>High CO Warning.</b> Move generator to an open, outdoor area. Move to fresh air and get medical help if sick, dizzy or weak.
	<b>CO Shield System Fault.</b> Electrical issue, end of life.
	<b>Petrol Tank: Full</b>
	<b>Petrol Tank: Empty</b>

## Quick Start Label Symbols

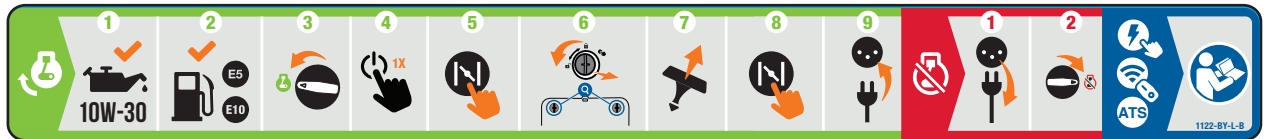

Some of the following symbols may be used on this product. Please study them and learn their meaning. Proper interpretation of these symbols will allow you to more safely operate the product.



### Starting the Engine

#### **! DANGER**

Move generator outside and far away from windows, doors and any intake ventilation covers.

1. **Check oil level.** Recommended oil is 10W-30. 
2. **Check petrol level.** When adding petrol, use a minimum octane rating of 85 and an ethanol content of 10% or less by volume. 
3. Turn the **fuel dial** to “ON” position.
4. Press the **Start/Stop button** to enter “STANDBY” mode. If the button does not illuminate, the battery is dead and the manual choke lever should be used in the next steps. See “Generator Battery” section for instructions on recharging the battery.
5. Press the **choke button**
6. Remove the **maintenance cover** on the right side of the control panel.
7. Pull the **recoil cord**.
8. Press the **choke button**.
9. Plug in desired device.

### Stopping the Engine

1. Turn off and unplug all connected electrical loads.
2. Turn the **fuel dial** to the “STOP” position.

### Electric, Wireless and ATS Start

See in “Operation” section.



## CONTROLS AND FEATURES

Read this operator's manual before operating your generator. Familiarize yourself with the location and function of the controls and features. Save this manual for future reference.

### Generator

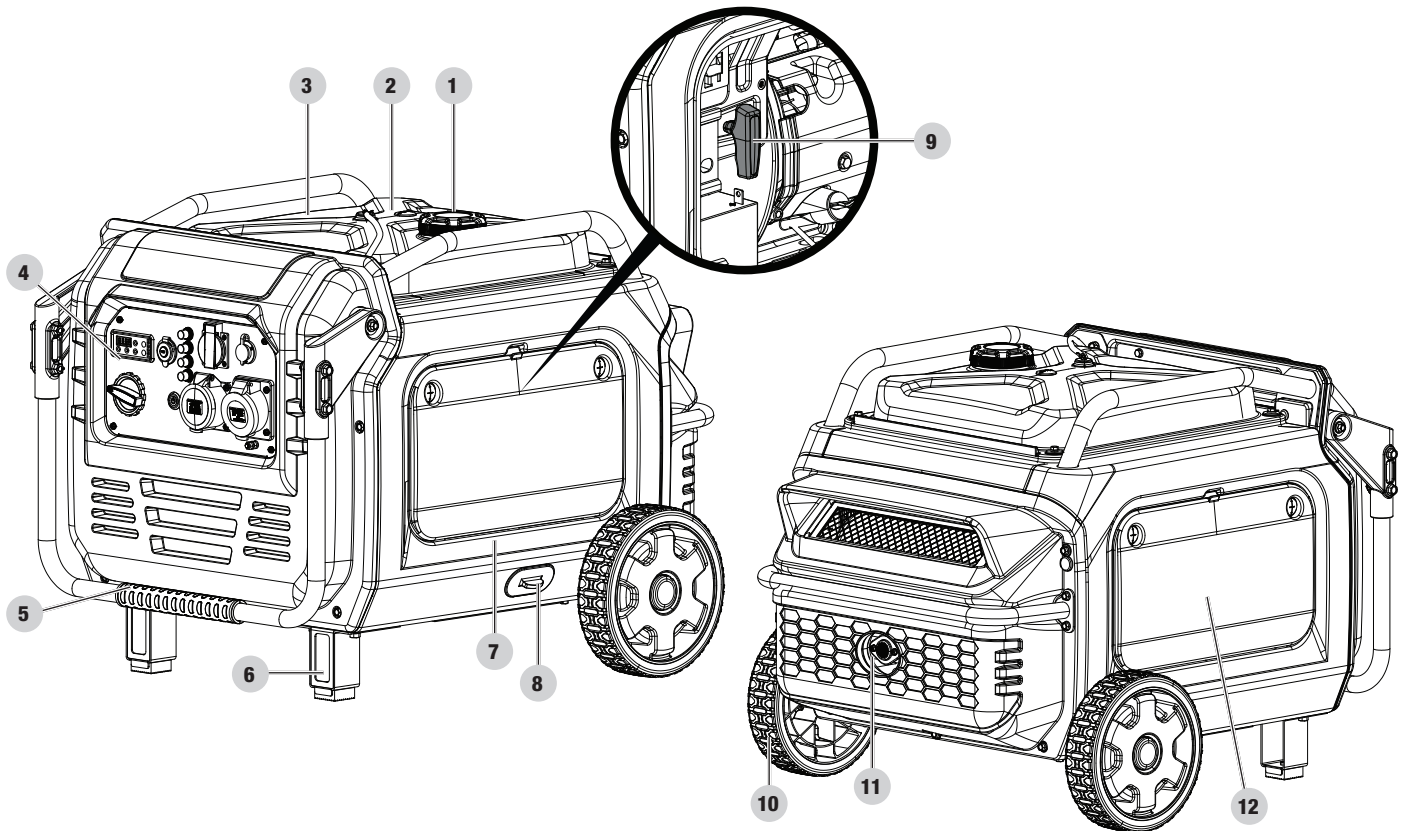

1. **Fuel Cap** – Remove to add fuel.
2. **Petrol Gauge**
3. **Petrol Tank** – 5.33 gal. (20.20 L)
4. **Control Panel** – See *Control Panel* section.
5. **Folding Handle** – Used to move unit by lifting and rolling on wheels. Do not use to lift or carry the unit.
6. **Support Leg**
7. **Oil Drain Hose Access Plug**
8. **Oil Drain Slot**
9. **Recoil Starter** – Used to manually start the engine (Remove cover).
10. **Never Flat Wheels** – 9.5 in. (24.1 cm)
11. **Muffler**
12. **Maintenance Cover**

Control Panel

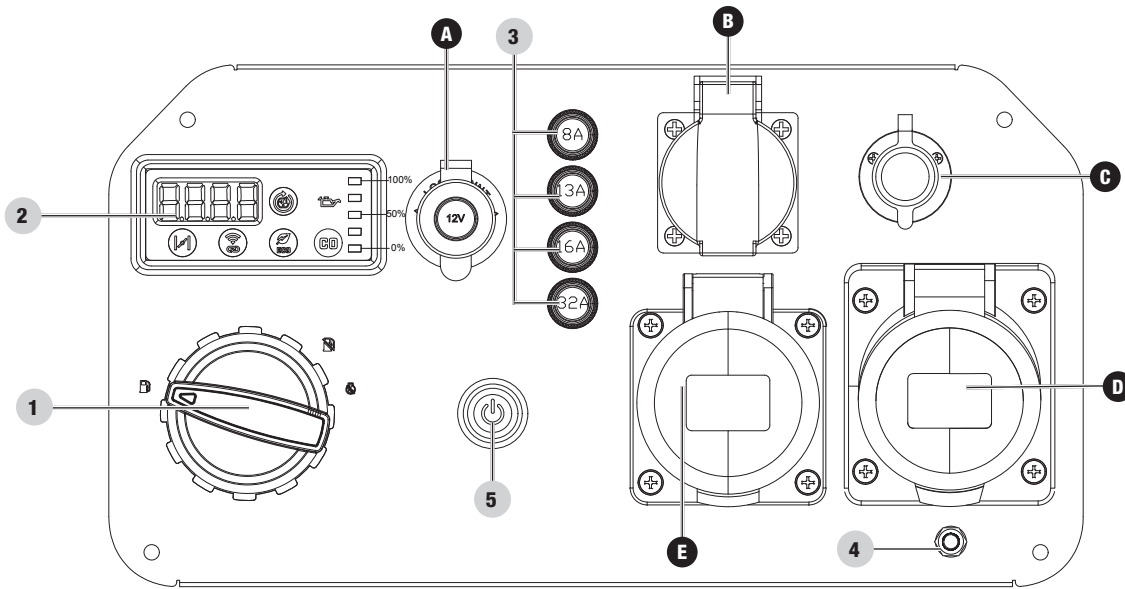

1. **Fuel Dial** – Used to start, stop and choke the generator.
2. **Intelligauge** – See *Intelligauge* section.
3. **Circuit Breakers (Push Reset)** – Protects the generator against electrical overloads.
4. **Ground Terminal** – Consult an electrician for local grounding regulations.
5. **Start/Stop Button**

**⚠ WARNING**

When charging a device, do not place on the exhaust side of the generator. Extreme heat caused by exhaust can damage the device and cause a potential fire hazard. Prolonged exposure to engine exhaust can cause serious injury or death.

RECEPTACLES		
A		<b>12V DC, 8A (Regulated Automotive)</b> May be used to supply electrical power for operation of 12 Volt DC, 8 Amp electrical loads.
B		<b>240V AC, 13A</b> May be used to supply electrical power for operation of 240 Volt AC, 13 Amp, single phase, 50 Hz electrical loads.
C		<b>ATS PORT</b> Used to transmit control signals with ATS.
D		<b>240V AC, 32A</b> May be used to supply electrical power for operation of 240 Volt AC, 32 Amp, single phase, 50 Hz electrical loads.
E		<b>240V AC, 16A</b> May be used to supply electrical power for operation of 240 Volt AC, 16 Amp, single phase, 50 Hz electrical loads.

Fuel Dial

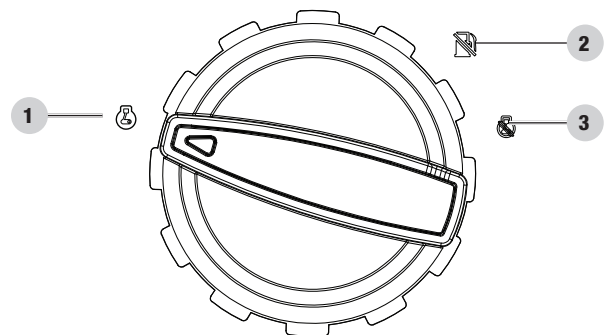

1. **Engine Run**
2. **Fuel Off**
3. **Engine Stop**

### Intelligauge with CO Shield®

Four mode digital meter for displaying voltage, frequency, session run time and total run time.

Muti-colored LED indicates CO shutoff or fault.

- A. **AC Overload Reset Button** – Used to re-energize receptacles after overload fault.
- B. **Low Oil Warning Indicator Light** – When ON, engine will shut down and not run. Check oil level.
- C. **Choke Button** – Used to start a cold engine.
- D. **Wireless Reset Button** – Used to reset or pair remote control(s).
- E. **Economy Mode Button** – Enables/disables automatic idle control.
- F. **CO Shield LED®** - The CO Shield® technology monitors for accumulation of poisonous carbon monoxide (CO) gas produced by engine exhaust when the generator is running. If CO Shield detects elevated levels of CO gas, it automatically shuts off the engine.

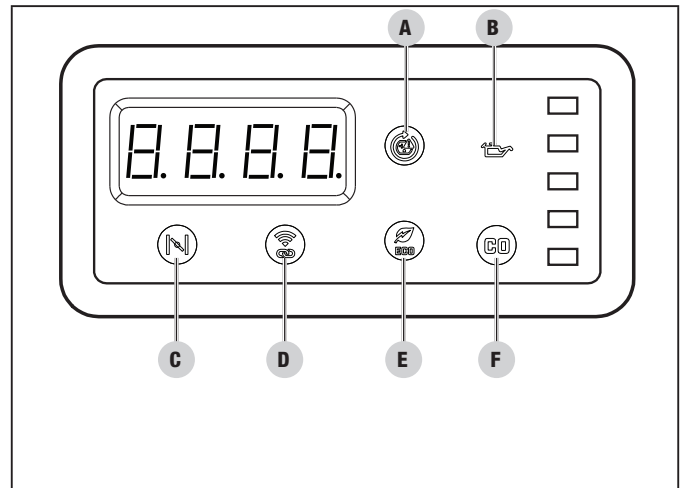

\* \*See CO Shield section for more information

MODE	DESCRIPTION	
Voltage (V)	Output voltage of the generator.	
	Example: 220 volts	
Frequency (H)	Output frequency in hertz.	
	Example: 50.0 hertz	
Run Time (R)	Run time of the generator for the current session.	
	Example: 6 hours	
Total Run Time	Total run time of the generator since first operation.	
	Example: 16 hours	
Power Meter	Power Output percentage.	
	Example: 80% Output	

### Wireless Remote Control

This generator is equipped with a wireless remote control system for starting and stopping. The system consists of (4) main components:

1. Receiver Control Module (RCM)
2. Remote Key Fob Transmitter
3. Start/Stop Button
4. Auto-Choke

**The Remote Control functions are enabled when the Start/ Stop button is in "STANDBY" mode and flashes green once per second.**

The remote key fob transmitter functions are disabled if the above condition is not met.

To start the generator wirelessly, press the "START"  button on the Remote Key Fob Transmitter one time. The engine will attempt to start (6) times. The RCM controls the Auto-Choke during each attempt to start.

To stop the generator wirelessly, press the "STOP" button on the remote key fob transmitter one time.

When the generator is off and you press Start/Stop button one time, the RCM is in standby mode and waiting for a remote signal. If you leave the generator in standby mode longer than twenty-four (24) hours, the remote function will disable itself to preserve battery life.

To disable standby mode before 24 hours, press and hold Start/ Stop button on the generator or press and hold the "STOP"  on the remote key fob transmitter for three (3) seconds until the light on the Start/Stop button goes out.

### Parts Included

#### Accessories

- Dual Port USB Adapter (5V/2.4A) ..... 1
- Remote Key Fob Transmitter ..... 2
- 12VDC Automotive Battery Charging Cable ..... 1

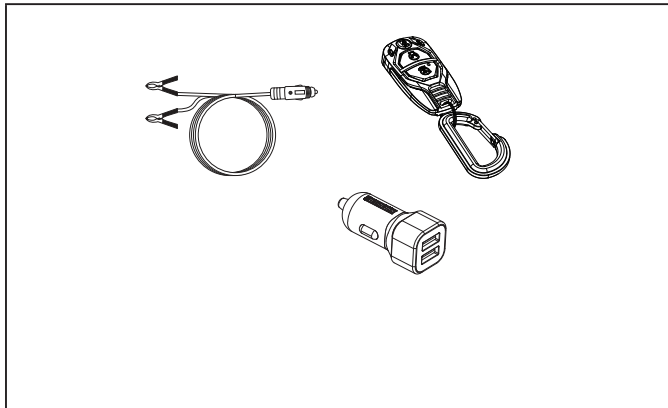

### Assembly Parts

#### Wheels

- 9.5 in. (24.1 cm) Never Flat Wheel (A) ..... 2
- Wheel hub caps (B) ..... 2
- Roll Pin (C) ..... 2
- Large R-clip (D) ..... 2

#### Support Leg

- Support Leg with Vibration Mounts (E) ..... 2
- Flange Bolt (M8×16)(F) ..... 4

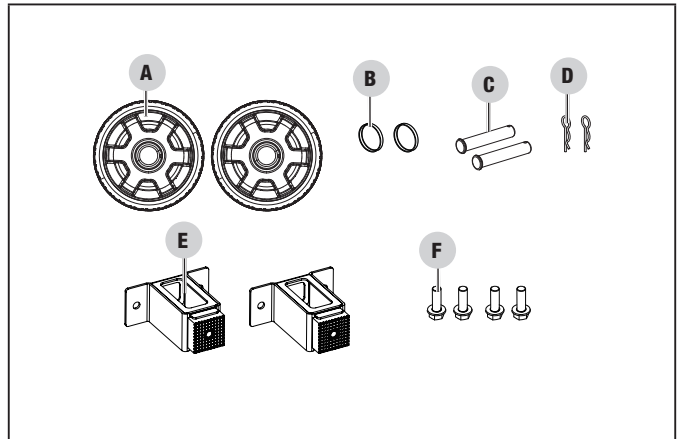

### Tools Needed

- Wrench/Socket set (metric)
- Pliers

### Tools Included

- Spark Plug Socket ..... 1
- Oil Funnel ..... 1

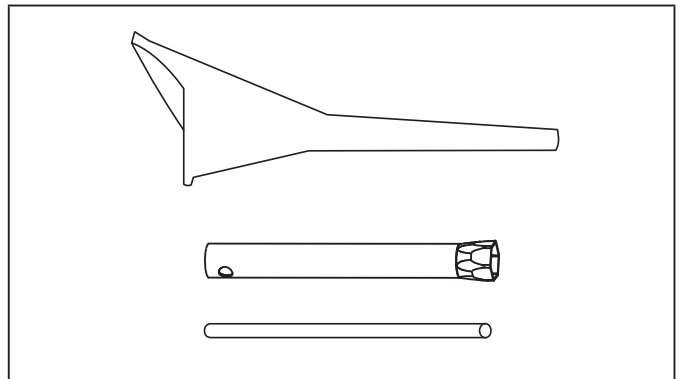

## ASSEMBLY

Your generator requires some assembly. This unit ships from our factory without oil. It must be properly serviced with fuel and oil before operation.

### Unpacking

1. Set the shipping carton on a solid, flat surface.
2. Remove everything from the carton except the generator.
3. Carefully cut each corner of the box from top to bottom. Fold each side flat on the ground to provide a surface area to work with the generator.

### Remove Shipping Support Hardware

To protect the generator during shipping, support hardware has been installed between the engine and frame. This hardware **MUST BE REMOVED BEFORE** adding oil or petrol to the generator.

#### IMPORTANT NOTICE

DO NOT attempt to run generator without first removing the shipping support hardware. Damage to the generator as a result of not removing the hardware will void the warranty.

1. **BEFORE** filling the engine with oil or petrol, tip the generator onto its side as shown. Tip onto the flattened cardboard box the generator came in or other protective surface so as to not scratch the frame.
2. Remove the orange bolts from the bottom panel. Bolts can be discarded.

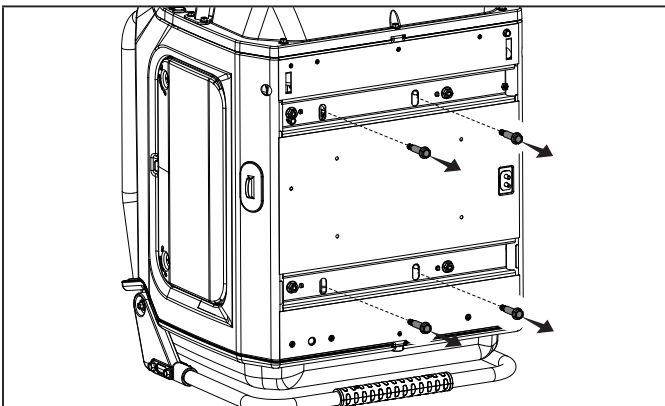

### Install the Wheel Kit

#### CAUTION

The wheel kit is not intended for over-the-road use.

#### Install the Wheels

1. Before adding fuel and oil, ensure the generator is still on its side from previous step.
2. Slide the roll pin (C) through the wheel (A) from the outside.
3. Slide the roll pin through the mount point on the frame.
4. Insert r-clip (D) into hole at end of roll pin.
5. Install hub cap (B) on wheel.

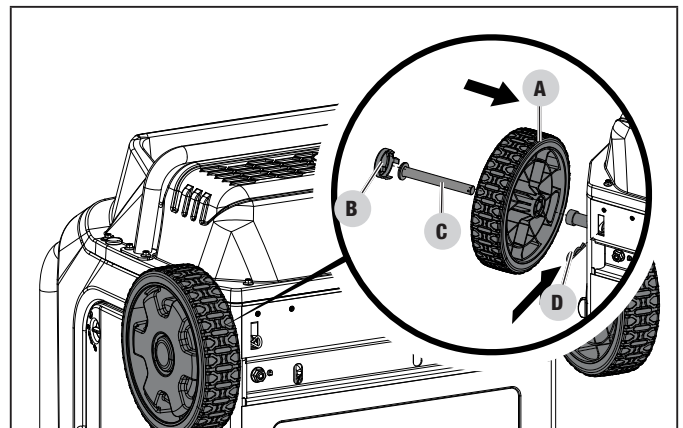

6. Roll the generator onto the other side and repeat above steps to attach the second wheel.

#### Install the Support Leg

1. Attach the support leg (E) to the generator frame with flange lock bolts (F).

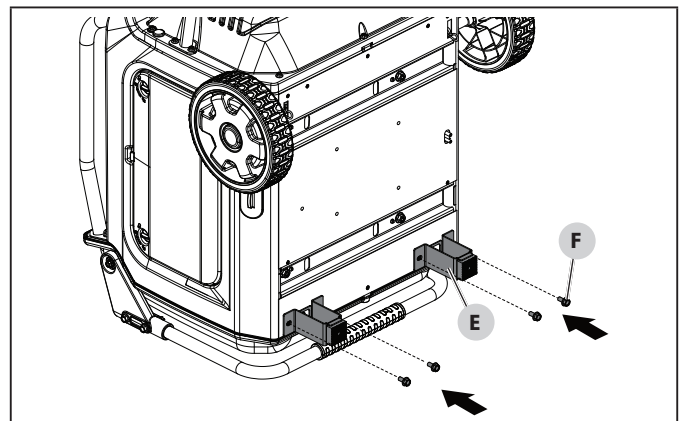

2. Tip the generator upright. Do not leave generator tilted on its side unattended or for an extended period.

### Connect the Battery

1. Place the generator on a flat, level surface.
2. Loosen the two cover screws and remove the maintenance cover.

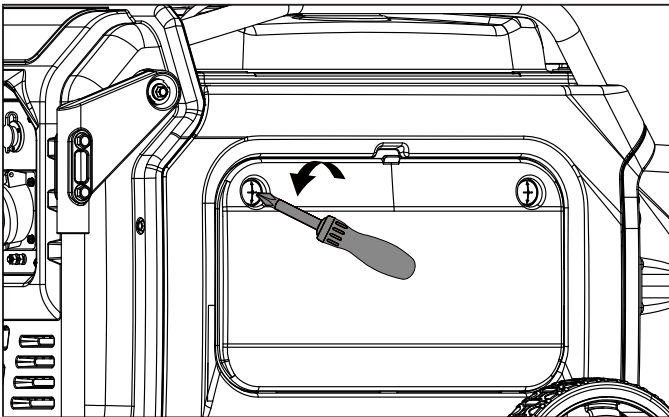

3. Push two halves of battery connector together tightly.

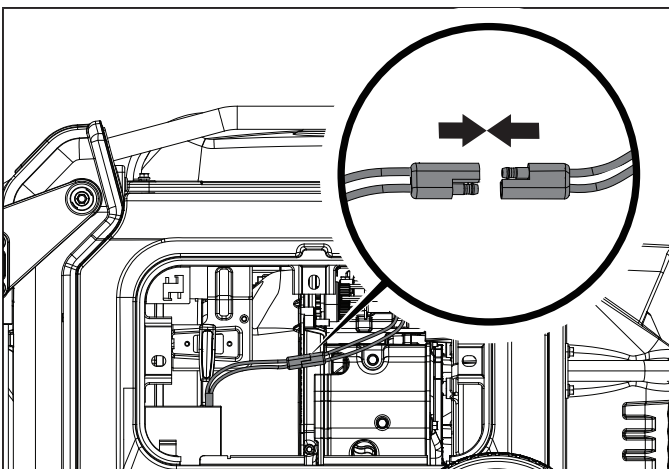

### Add Engine Oil



#### ⚠ WARNING

DO NOT attempt to crank or start the engine before it has been properly filled with the recommended type and amount of oil. Damage to the generator as a result of failing to follow these instructions will void your warranty.

#### 🗨 NOTICE

The generator rotor has a sealed, pre-lubricated ball bearing that requires no additional lubrication for the life of the bearing.

#### 🗨 NOTICE

The recommended oil type for typical use is **10W-30 automotive oil**. However, using the listed conventional oils shown in the “Recommended Engine Oil Type” chart may be used for typical use including the first 5 hours of the break-in run time period of the engine.

If running generator in extreme temperatures, refer to the “Recommended Engine Oil Type” chart.

Recommended Engine Oil Type	
10W-30	
5W-30	
10W-40	
5W-30 Full Synthetic	
°F	-20    0    20    40    60    80    100    120
°C	-28.9    -17.8    -6.7    4.4    15.6    26.7    37.8    48.9
Ambient temperature	

1. Place the generator on a flat level surface. Do Not angle or tip the generator when adding oil.
2. Loosen the two cover screws and remove the maintenance cover.

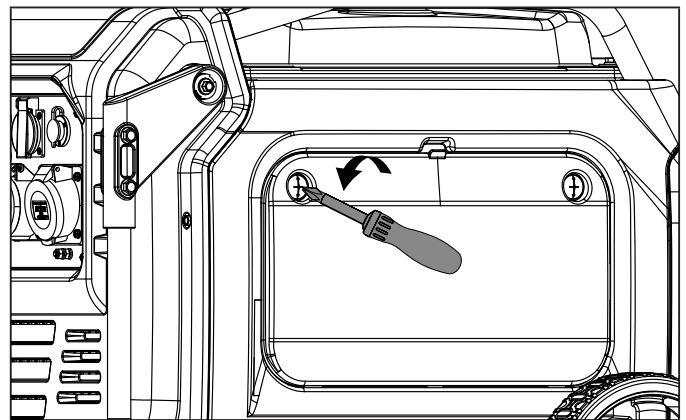

3. Remove oil fill cap/dipstick to add oil.



4. Using a funnel, add up to 37.2 fl. oz. (1100 ml) of oil. DO NOT OVERFILL. Replace oil fill cap/dipstick and secure cover.

### NOTICE

When using the dipstick to check oil level, DO NOT screw in the dipstick while checking, simply rest it against the top of the port.

As a general rule oil is full when it can be seen visually on the middle to upper threads of the port. Do Not angle or tip the generator when adding oil.

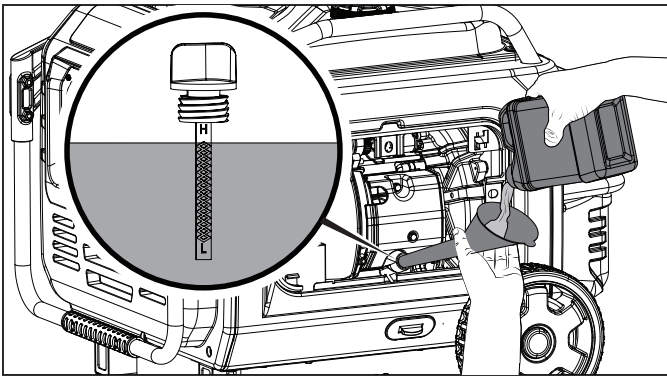

5. Check engine oil level before every use and add as needed.

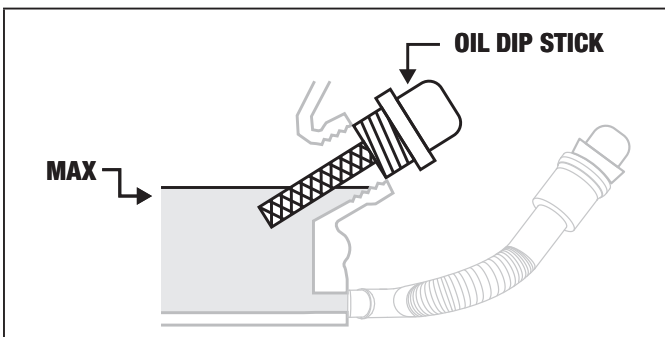

### NOTICE

Once oil has been added, a visual check should show oil about 1-2 threads from running out of the fill hole.

When using the dipstick to check oil level, DO NOT screw in the dipstick while checking, simply rest it against the top of the port.

As a general rule oil is full when it can be seen visually on the middle to upper threads of the port. Do Not angle or tip the generator when adding oil.

### NOTICE

Check oil level often during the break-in period. Refer to the Maintenance section for recommended service intervals.

### CAUTION

This engine is equipped with a low oil shut-off and will stop when the oil level in the crankcase falls below the threshold level.

### NOTICE

The first 5 hours of run time are the break-in period for the unit. During the break in period stay at or below 50% of the running watt rating and vary the load occasionally to allow stator windings to heat and cool. Adjusting the load will also cause engine speed to vary slightly and help seat piston rings. After the 5 hour break-in period, change the oil.

### NOTICE

Synthetic oil may be used after the 5 hour initial break-in period. Using synthetic oil does not decrease the recommended oil change interval. Full synthetic 5W-30 oil will aid in starting in cold ambient < 41° F (5° C) temperatures.

## Add Fuel

### DANGER

Petrol vapors are highly flammable and extremely explosive.

DO NOT light or smoke cigarettes. Fire or explosion can cause severe burns or death.

Only fill or drain fuel outdoors in a well-ventilated area. DO NOT pump petrol directly into the generator. Use an approved container to transfer the fuel to the generator.

Never use a petrol container, fuel tank, or any other fuel item that is broken, cut, torn or damaged.

DO NOT overfill the fuel tank. Always keep fuel away from sparks, open flames, pilot lights, heat and other sources of ignition.

Use clean, fresh, regular unleaded petrol with a minimum octane rating of 85 and an ethanol content of 10% or less by volume.



DO NOT mix oil with petrol.

1. Remove the fuel cap.

2. Slowly add petrol to the tank. Tank is full when petrol reaches red circle on screen. **DO NOT OVERFILL.** Petrol can expand after filling. A minimum of ¼ in. (6.4 mm) of space left in the tank is required for petrol expansion, although more than ¼ in. (6.4 mm) is recommended. Petrol can be forced out of the tank as a result of expansion if overfilled, and can affect the stable running condition of the generator.

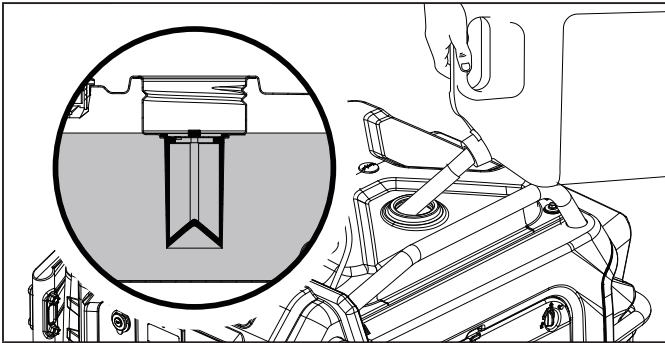

3. The approximate fuel level is shown on the fuel gauge on top of the fuel tank.

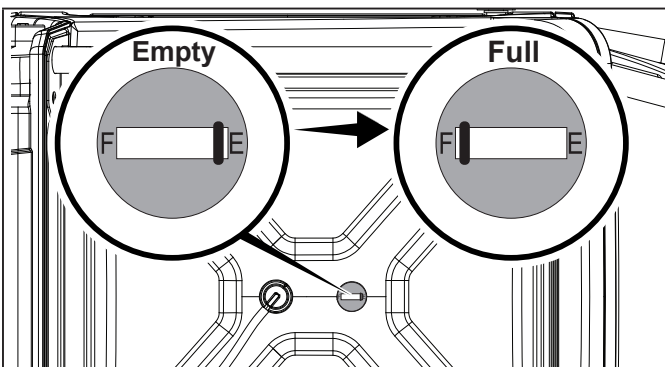

4. Screw on the fuel cap and wipe away any spilled fuel.

### ⚠ CAUTION

Use unleaded petrol with a minimum octane rating of 85 and an ethanol content of 10% or less by volume. **E5 E10**

DO NOT light cigarettes or smoke when filling the tank.

DO NOT mix oil and petrol, this is a four stroke engine with separate oil and petrol.

DO NOT overfill the tank. Fill tank to approximately ¼ in. (6.4 mm) below the top of the tank to allow for petrol expansion.

DO NOT pump petrol directly into the generator at the pump. Use an approved fuel container to transfer the petrol to the generator.

DO NOT fill fuel tank indoors, in garages, in sheds or in any out building.

DO NOT fill tank when the engine is running or hot, always allow engine to cool minimum 30 mins before refueling.

### ⚠ WARNING

Pouring petrol too fast through the fuel screen may result in petrol splashing over the generator and operator while filling.

### 🗨 NOTICE

The generator engine works well with 10% or less ethanol blended petrol. When using ethanol-petrol blends there are some issues worth noting:

- Ethanol-petrol blends can absorb more water than petrol alone.
- These ethanol blends can eventually separate, leaving water or a watery goo in the tank, fuel valve and carburetor. The compromised petrol can be drawn into the carburetor and cause damage to the engine and/or create potential hazards.
- If a fuel stabilizer is used, confirm that it is formulated to work with ethanol-petrol blends.
- Any damages or hazards caused by using ethanol blended petrol higher than 10% by volume, improperly stored petrol, and/or improperly formulated stabilizers, are not covered by manufacturer's warranty.

It is advisable to always shut off the petrol supply and run the engine to starvation after each use. See Storage instructions for extended non-use.

## Grounding

It is recommended your generator is properly connected to an appropriate ground to help prevent electric shock.

### ⚠ WARNING

Failure to properly ground the generator can result in electric shock.

A ground terminal connected to the frame of the generator has been provided (see Controls and Features for terminal location). For remote grounding, connect a length of heavy gauge (12 AWG minimum) copper wire between the generator ground terminal and a copper rod driven into the ground. We strongly recommend that you consult with a qualified electrician to ensure compliance with local electrical codes.



**Neutral Floating\*(This Generator)**

- Neutral circuit **IS NOT** electrically connected to the frame/ground of the generator.
- The generator (stator winding) is isolated from the frame and from the AC receptacle ground pin.
- Electrical devices that require a grounded receptacle pin connection will not function if the receptacle ground pin is not functional.

**Neutral Bonded to Frame\***

- Neutral circuit **IS** electrically connected to the frame/ground of the generator.
- The generator system ground connects lower frame cross-member below the alternator. The system ground is connected to the AC neutral wire.

\*See your Specifications section for specified type of grounding.

**OPERATION**

**CO Shield® - Carbon Monoxide (CO) Detection and Auto-shutoff System**

The CO Shield™ technology monitors the accumulation of poisonous CO gas produced by engine exhaust when the generator is running. If CO Shield detects elevated levels of CO gas, it automatically shuts off the engine. Generators are intended to be used outdoors, far away from occupied buildings and exhaust pointed away from people and buildings.

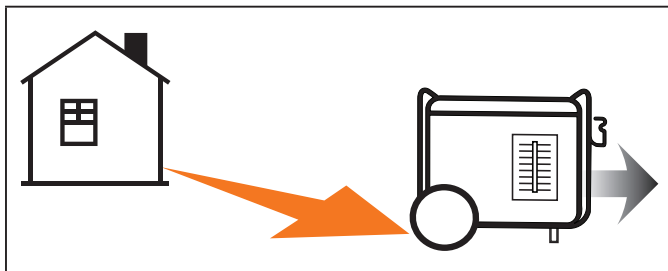

If misused and operated in a location that results in the accumulation of CO inside an enclosed or partially enclosed space, for example a house, garage or a garage with the door partially open, CO Shield will automatically shut off the generator and then illuminate a red LED. Read the action label for what steps to take. **CO Shield is not a substitute for an indoor carbon monoxide alarm.**

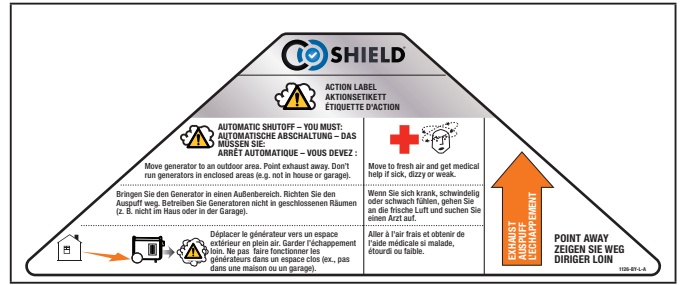

When you approach the generator to investigate a shut off, a blinking **red** LED light in the CO Shield area provides notification that the generator shut off due to an accumulating CO hazard. The red LED light will blink for at least five (5) minutes after a shutoff event.

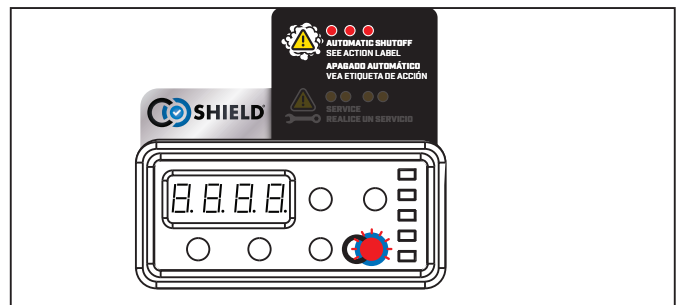

Move the generator to an open, outdoor area and point the exhaust away from people and buildings. Once relocated to a safe area, the generator can be restarted, and the proper electrical connections made. Introduce fresh air and ventilate the location where the generator shut off.

When starting, the red and yellow LED will blink ten (10) times simultaneously to indicate the LED is working.

**NOTICE**

This blinking does not indicate CO Shield is working, as CO Shield is working at all times the generator is running. Also, the LED will not blink (10) times if the generator was restarted within 1 minute after it was manually shut off. This does not occur if generator shut off from a high CO event.

If CO Shield system experiences a fault and no longer provides protection, the generator is shutoff automatically and the **yellow** LED light will blink for at least five (5) minutes to notify you of the fault.

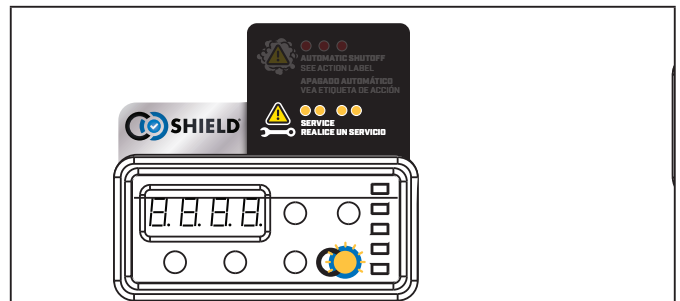

CO Shield will detect the accumulation of carbon monoxide from other fuel burning sources such as engine powered tools, or propane heaters used in the area of operation. If another generator is used and the exhaust is pointed at a CO Shield equipped generator, the CO Shield may initiate a shutoff due to rising carbon monoxide levels. This is not a fault. Hazardous carbon monoxide has been detected. You must take action to move and direct the equipment to better dissipate carbon monoxide far away from people or buildings.

### WARNING

Tampering with the CO Shield® system could result in a hazardous condition and will void your warranty.

Removing the CO Shield module will not allow the generator to start.

## Generator Location

### WARNING

NEVER operate the generator inside any building, garage, basement, crawlspace, shed, enclosure or compartment, including a generator compartment of a recreational vehicle.

NEVER operate or start the generator in the back of an SUV, camper, trailer, truck bed (regular sides, flat or other configuration), under staircases, stairwells, next to walls or buildings or in any other location that will not allow for adequate cooling of the generator or for the proper exit of the exhaust flow from the muffler system.

DO NOT operate or store the generator in wet weather conditions such as rain or snow. Using a generator in wet conditions could result in serious injury or death due to electrocution.

In some state's generators may be required to be registered with the local utility company when used at construction sites and may be subject to additional rules and regulations, consult your local municipal authority.

Generators should always be operated on a flat, level surface at all times (even when not in operation).

Generators must have a minimum of 5 feet (1.5 m) of clearance from all combustible material.

Generators must also have a minimum of 3 feet (91.4 cm) of air flow clearance on all sides to allow for adequate performance cooling, maintenance and servicing.

Always place the generator in a well-ventilated area. NEVER place the generator near air intake vents or where exhaust fumes could be drawn into occupied or confined spaces.

Always carefully consider wind and air currents when positioning generator.

Always allow generators to properly cool before transport or for storage purposes.

Failure to follow proper safety precautions may result in personal injury, damage to the generator and void the manufacturer's warranty.

### WARNING

During operation the muffler and exhaust fumes will become hot. If adequate cooling and breathing space are not supplied, or if the generator is blocked or enclosed, temperatures can become extremely heated and may lead to fire.

### WARNING

Do Not modify or install any extensions or extraction to the exhaust/muffler, by doing so will void any warranty.

**⚠ WARNING**

Do not expose to rain or use in damp locations.  
 Keep all objects a minimum of 5 feet (1.5m) away from the generator at all times. Heat from the muffler surface and exhaust gas stream can ignite combustible materials.

**⚠ WARNING**

If you must operate in rain or damp locations, DO NOT operate without proper protection of the electrical components.

Use of a safety canopy that is fire retardant and will provide proper air ventilation for the engine exhaust gas stream may be used.

**Wireless Set Button**

The wireless set button is a feature that lets the user synchronize the remote key fob transmitter to the generator. Up to two remote key fobs transmitter can be synchronized to the generator at a time. Follow the proceeding steps to reset a remote or synchronize two remotes:

1. Turn the fuel dial to the "ON" position.

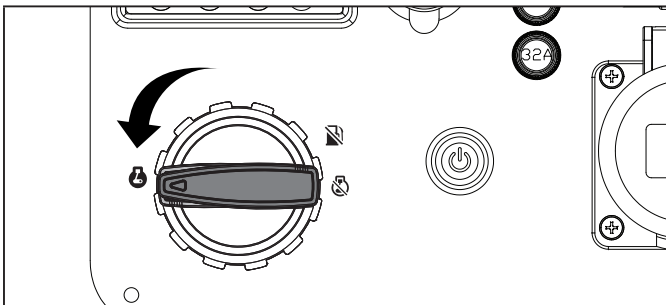

2. Press the Start/Stop button to enter standby mode.

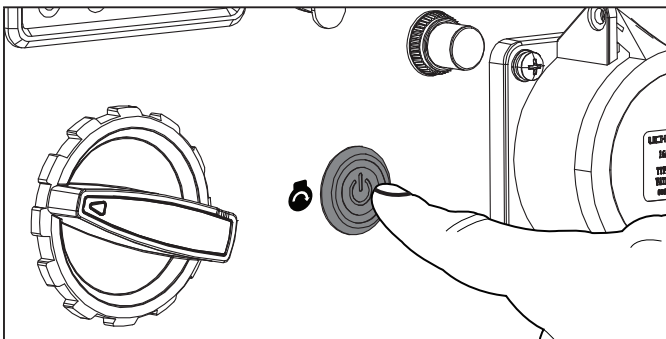

3. Push and hold the wireless set button found on the Intelligauge for approximately three seconds until the button LED illuminates blue.

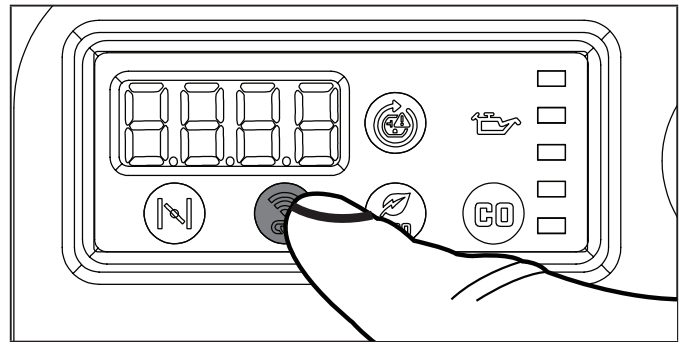

4. Push and release the "STOP" button on the remote key fob transmitter. The green LEDs on the remote key fob and the Start/Stop button will blink once simultaneously to indicate program is erased and generator is ready for pairing.

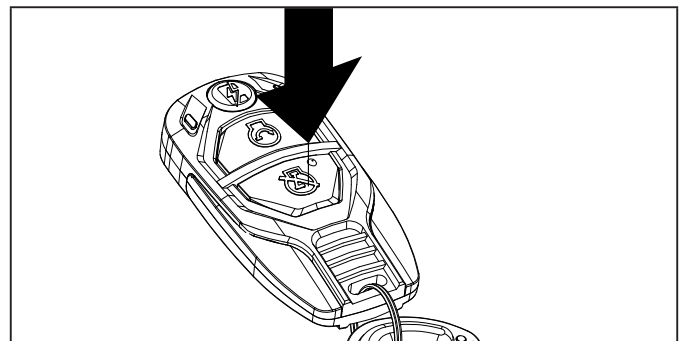

5. Push and release the "START" button on the remote key fob transmitter. The green LEDs on the remote key fob and the Start/Stop button will blink once simultaneously to indicate the remote has been programmed."

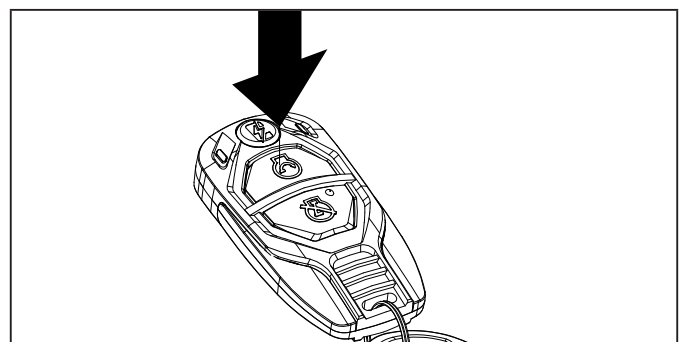

6. Push and hold the wireless set button for approximately three seconds until the blue LED on wireless set button turns off.

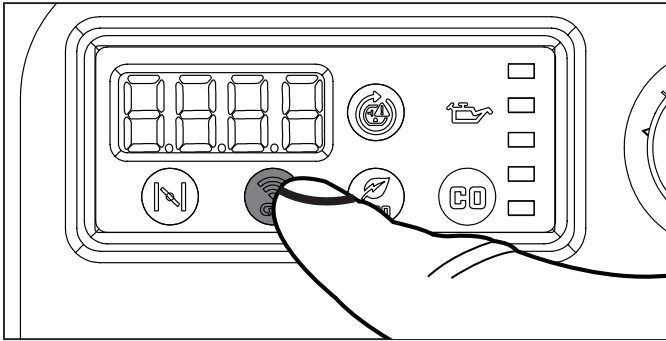

7. Follow the remote START and STOP instructions to verify the remote(s) are working properly.

### NOTICE

Only two remote key fobs transmitter can be synchronized to the generator at one time. If pairing second remote and do not want to erase programming on current remote, skip step 4.

### NOTICE

Changing a remote key fob transmitter battery may not require the user to reset the remote. If remote does not function after changing the battery, proceed with Wireless Set Button instructions.

## Surge Protection

Electronic devices, including computers and many programmable appliances use components that are designed to operate within a narrow voltage range and may be affected by momentary voltage fluctuations. While there is no way to prevent voltage fluctuations, you can take steps to protect sensitive electronic equipment.

- Install UL1449, CSA-listed, plug-in surge suppressors on the outlets feeding your sensitive equipment. Surge suppressors come in single- or multi-outlet styles. They're designed to protect against virtually all short-duration voltage fluctuations.

## Starting the Engine: No ATS or ATS on Manual Mode

### Manual Start

1. Make certain the generator is on a flat, level surface.
2. Disconnect all electrical loads from the generator. Never start or stop the generator manually with electrical devices plugged in or turned on.
3. Turn the fuel dial to the "ON" position.

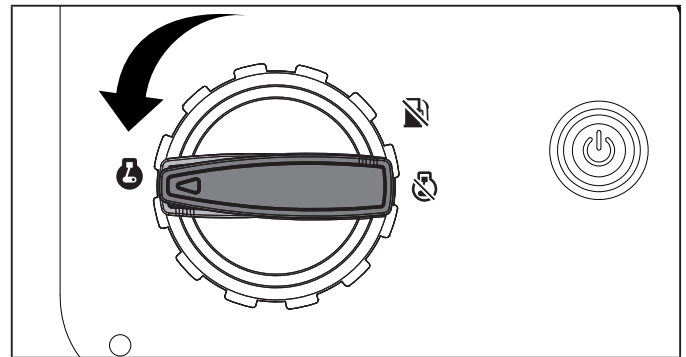

4. Press the Start/Stop button to enter standby mode. The button will flash green but the generator will not attempt to start.

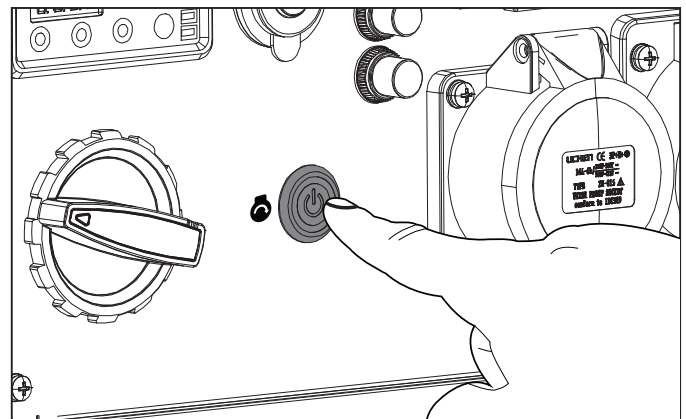

5. Press the "CHOKE" button.

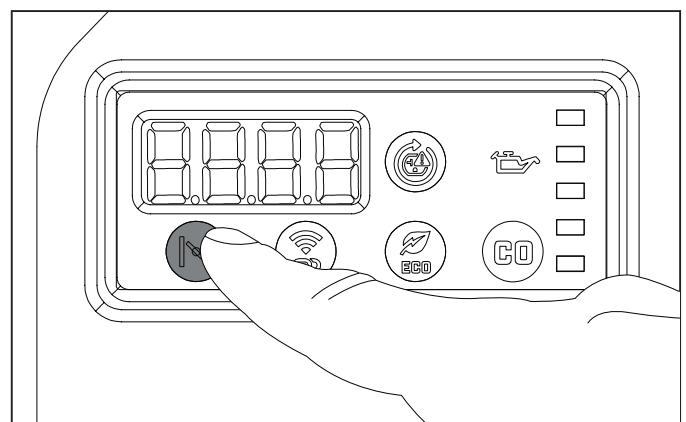

- Loosen the two cover screws and remove the maintenance cover.

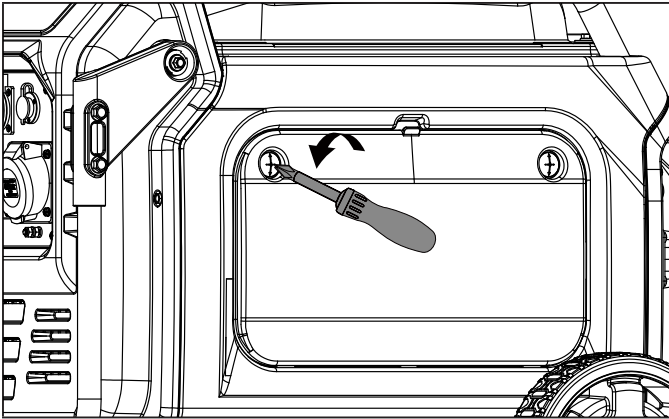

- When starting the engine, pull the recoil cord slowly until resistance is felt, release cord back and with one strong rapid pull to start, this avoids any kickback or damage to the recoil assembly. If the engine doesn't start repeat this process.

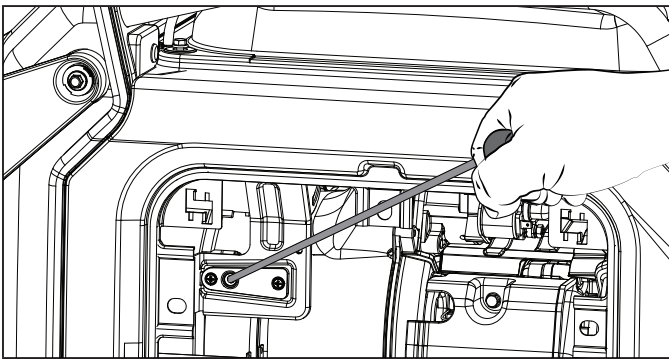

**⚠ CAUTION**

Rigorously or aggressively pulling the recoil cord will result in damage to the recoil assembly and void any warranty.

- Do not over-choke. As soon as engine starts, push the choke button one time to set the choke to the "RUN" position. Choke button will no longer be illuminated when in "RUN" position

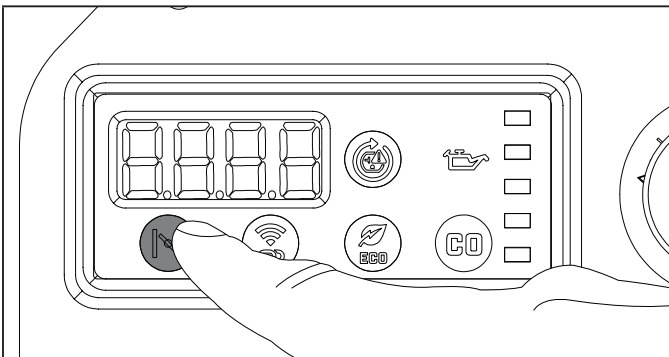

- Re-install the maintenance cover.

**Electric Start**

- Make certain the generator is on a flat, level surface.
- Disconnect all electrical loads from the generator. Never start or stop the generator with electrical devices plugged in or turned on.
- Turn the fuel dial to the "ON" position.

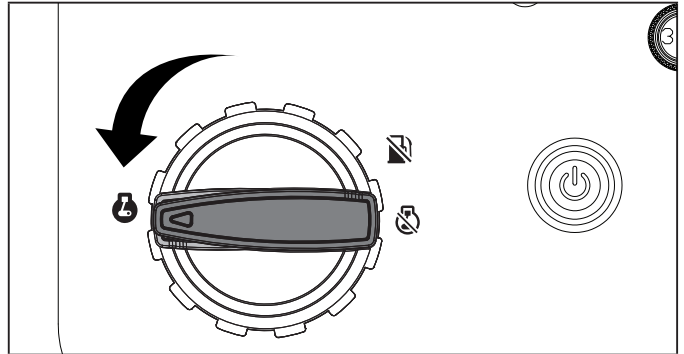

- Press the Start/Stop button to enter standby mode. The button will flash green but the generator will not attempt to start.

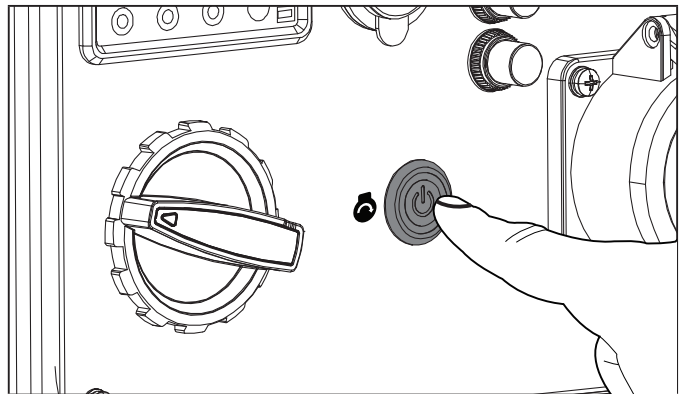

- Press the Start/Stop button a second time. The button will now flash green and the generator will attempt to start. There will be (6) starting attempts. After generator starts, the button will turn solid green.

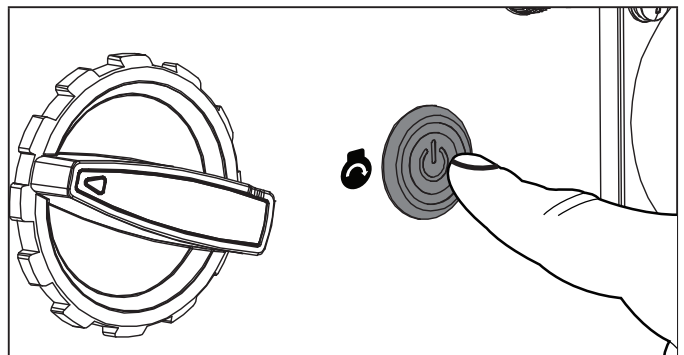

### Wireless Remote Start

Wireless remote starting is only possible within 80 feet of the generator.

DO NOT attempt to adjust the choke. The remote system will automatically close and open the choke.

1. Make certain the generator is on a flat, level surface.
2. Disconnect all electrical loads from the generator. Never start or stop the generator with electrical devices plugged in or turned on.
3. Turn the fuel dial to the "ON" position.

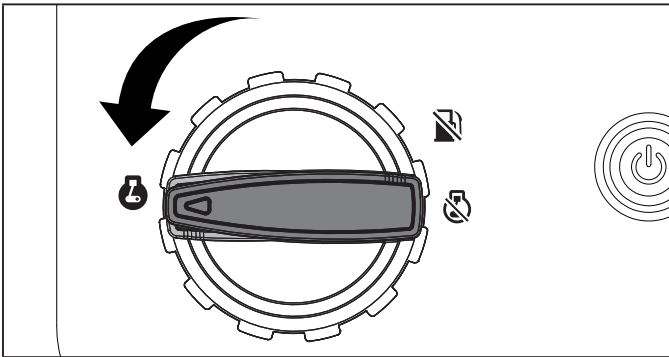

4. Press the Start/Stop button to enter standby mode. If generator was turned off using the remote key fob transmitter within the last 24 hours, it will already be in standby mode. The button will flash green but the generator will not attempt to start.

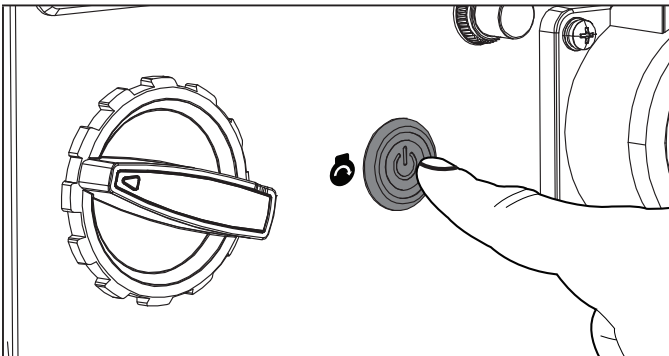

5. Press and release the "START" button on the remote control transmitter. DO NOT hold the button down, only press the button once. The engine will attempt to start six times.

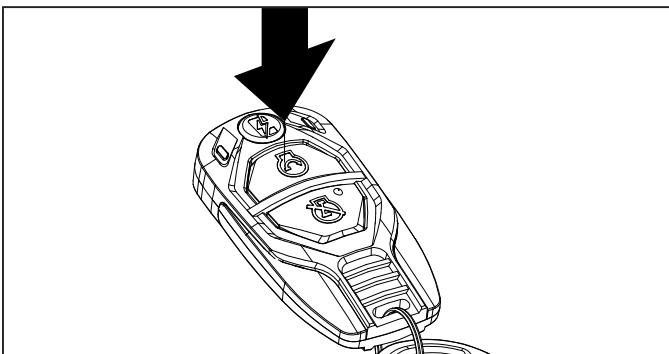

### NOTICE

If CO Shield detects elevated levels of CO gas resulting in the generator shutting down, Wireless Remote starting will become disabled and will not be able to restart the generator. Move generator to an open, outdoor area and point the exhaust away from people and buildings. Once relocated to a safe area, the generator can be restarted by either using the Electric Start or Manual Start instructions. Once the generator is restarted, the Wireless Remote starting will be active again and can be used to START/STOP the generator.

### Starting the Engine: ATS on Automatic Mode

1. Make certain the generator is on a flat, level surface.
2. Turn the fuel dial to the "ON" position.

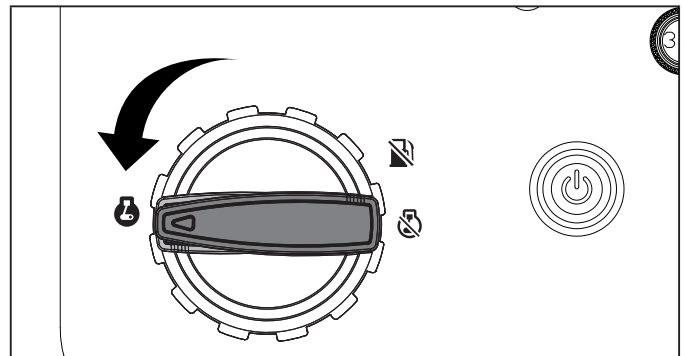

3. Press the Start/Stop button to enter standby mode. The button will flash green but the generator will not attempt to start.

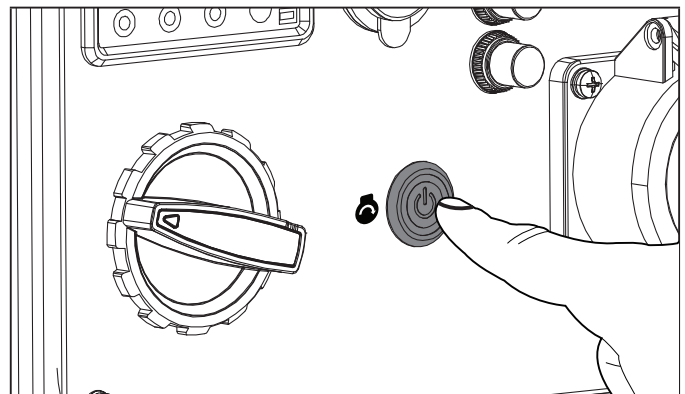



4. Insert the ATS connector into the ATS interface between ATS and generator. (Not Included, ATS Panel and Communication lead sold Separately)

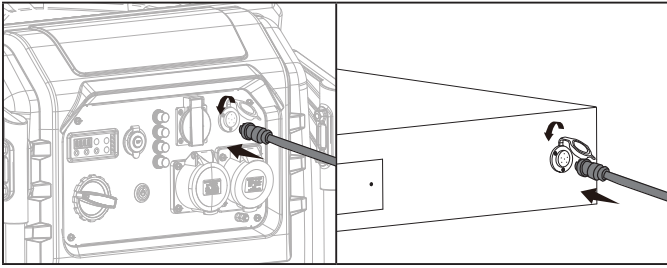

5. Connect ATS to utility power, the "MAINS" indicator on the ATS chassis panel will be light.

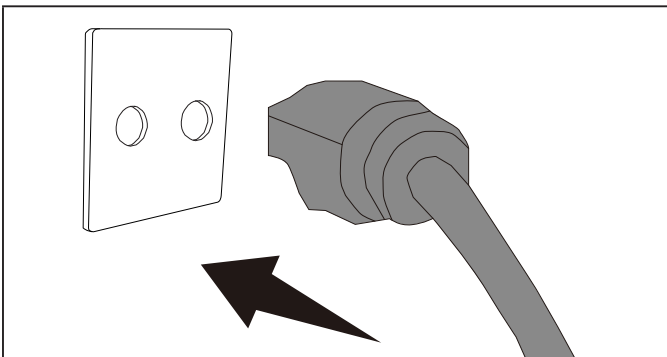

6. Connect ATS to generator power.

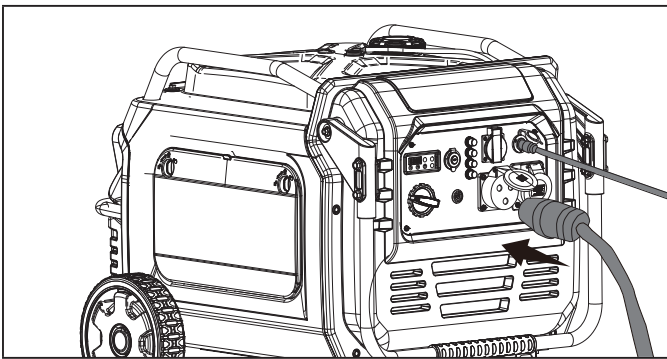

7. Press the AUTO button on the ATS chassis panel, the "AUTO" indicator will be light.

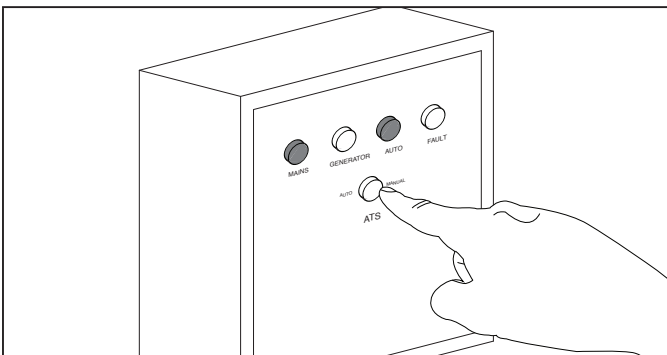

8. When the utility power go off, the generator will start automatically.

**NOTICE**

**For petrol restarts with hot engine and(or) in hot ambient temperature >86°F (30°C):** Rotate the fuel dial to the "CHOKE" position for only one pull of the recoil cord. If generator does not start after first pull, rotate the dial to the "RUN" position for the next three pulls. Too much choke leads to spark plug fouling and engine flooding. This will cause the engine not to start.

**NOTICE**

**For petrol starting in standard ambient temperature >59°F (15°C):** Keep fuel dial in "CHOKE" position for three pulls of the recoil cord. If generator does not start after three pulls, rotate the fuel dial to the "RUN" position for the next three pulls. Too much choke leads to spark plug fouling and engine flooding. This will cause the engine not to start.

**NOTICE**

**For petrol starting in cold ambient temperature < 59°F (15°C):** Keep the fuel dial in the "CHOKE" position until engine starts. As soon as the engine starts and runs smoothly turn the fuel dial to the "RUN" position. In extreme cold temperatures, this may take several seconds.

**NOTICE**

If the engine starts but does not continue to run make certain that the generator is on a flat, level surface. The engine is equipped with a low oil sensor that will prevent the engine from running when the oil level falls below a critical threshold.

## Battery

### NOTICE

The supplied 12V battery does re-charge while the engine is running and the battery switch is turned ON, but it is also recommended that the battery be fully charged at least once per month or maintained with a trickle charger or battery maintainer (not included).

## Connecting Electrical Loads

Let the engine stabilize and warm up for a few minutes after starting.

Plug in and turn on the desired 240 Volt AC single phase, 50 Hz electrical loads.

- DO NOT connect 3-phase loads to the generator.
- DO NOT overload the generator.
- Use only a high quality, insulated, compatible (3-wire or 4-wire) grounded cord set rated equal to or greater (volts and amps) than the receptacle plugging into.

### WARNING

Always remember to plug your appliances directly into the generator and do not plug the generator power cord into any electrical outlet or connect to the circuit breaker panel in your home. Connecting a generator to your home's electric utility company's power lines, or to another power source, called 'backfeeding' is a dangerous practice that is illegal in many states and municipalities.

This action if done incorrectly could damage your generator, appliances and could cause serious injury or death to you or a utility worker when attempting to restore power during an outage occurrence in the neighborhood who may then unexpectedly encounter high voltage on the utility line and suffer a fatal shock.

Whether injuries occur or not, if installed incorrectly and not to applicable laws and codes, you may be subject to fines or the utility company may disconnect your home power should this practice be found in your home.

If the generator will be connected to a building electrical system, those connections must isolate the generator power from the utility power. You are responsible for ensuring your generator's electricity does not backfeed into the electric utility power lines. These connections must comply with all applicable laws and codes – Consult your local utility company or a qualified electrician to properly install this connection.

## Do Not Overload Generator

### Capacity

Follow these simple steps to calculate the running and starting watts necessary for your purposes:

1. Select the electrical devices you plan on running at the same time.
2. Total the running watts of these items. This is the amount of power you need to keep your items running.
3. Identify the highest starting wattage of all devices identified in step 1. Add this number to the number calculated in step 2. Starting wattage is the surge of power needed to start some electric driven equipment. Following the steps listed under "Power Management" will guarantee that only one device will be starting at a time.
4. If the generator power output is cut off due to an overload condition indicated by the AC overload blinking light, lower the load by unplugging one or more items, then press the AC overload reset button before restarting the generator for continued normal operation.

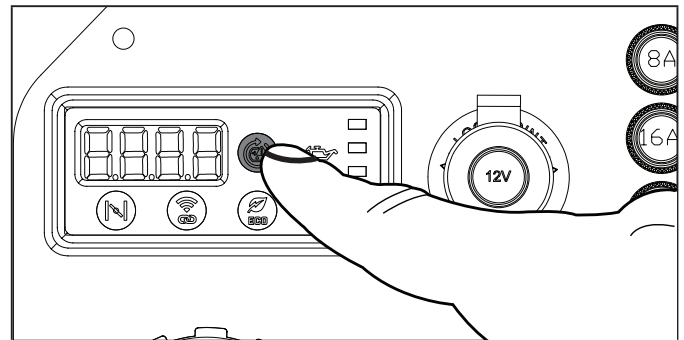

### Power Management

Use the following formula to convert voltage and amperage to watts:

$$\text{Volts} \times \text{Amps} = \text{Watts}$$

To prolong the life of your generator and attached devices, follow these steps to add electrical load:

1. Start the generator with no electrical load attached.
2. Allow the engine to run for several minutes to get up to temperature.
3. Make sure all circuit breakers are set to the run position.
4. Plug in and turn on the first item. It is best to attach the item with the largest load first.
5. Allow the engine to stabilize.
6. Plug in and turn on the next item.
7. Allow the engine to stabilize.
8. Repeat steps 5-6 for each additional item.



**NOTICE**

Never exceed the specified capacity when adding loads to the generator.

**Box System ATS User Manual**

**ATS Working logic**

1. ATS Automatic mode

Press the 'Auto' button on the ATS control panel, this will switch the ATS panel to automatic mode, ATS panel will detect a drop or loss of city power and send a control signal (circular connector: Communication lead) to start the generator.

When ATS detects the city power is normal, ATS panel will send out a control signal to stop generator. Note: This may take up to 30 seconds for the generator to stop whilst the city power is back on.

When ATS detects a drop or loss of main city power for 5 seconds, ATS sends a control signal to start the generator.

After ATS detects the standby generator power is normal for 5 seconds the load is automatically switched to generator power supply mode (Standby / Auxiliary)

When in generator power supply mode (Standby / Auxiliary), when ATS detects the mains city power is restored to normal for approx 5 seconds, The ATS sends a change-over signal, and the load output is changed from the standby / Auxilliary generator power supply mode to the mains city power supply mode. The ATS also sends a signal to stop the generator running.

**NOTICE**

Generator runs without load for approx 20 seconds along side restored city power.

When the ATS panel sends a start signal and the generator starts successfully but the ATS panel detects that the AC voltage output supplied by the generator is abnormal the fault light on the ATS panel will illuminate and flash. If after 10 seconds of ATS panel detection, the abnormal AC voltage of the generator did not restore to normal the ATS panel will send a stop signal, and the generator will stop running.

**NOTICE**

The fault light on ATS panel will continually flash all the time until it is reset. After the fault of the generator is determined or removed, it is necessary to restart the ATS panel (Press 'OFF' and then back 'ON' again).

2. ATS manual mode

When ATS 'Auto' button is not pressed ATS panel is in manual mode.

3. ATS panel provides a battery charging feature, this is 13.8v 2A.

4. ATS access to power system diagram.

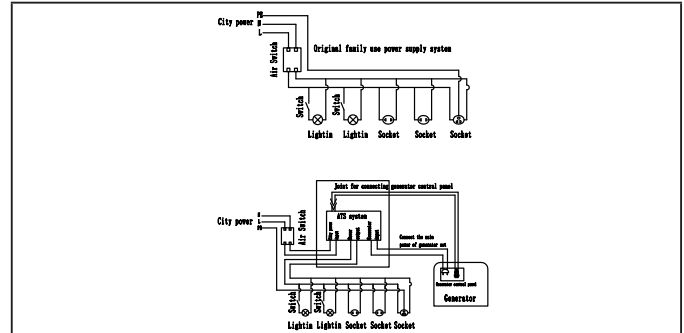

5. Circular connector wiring

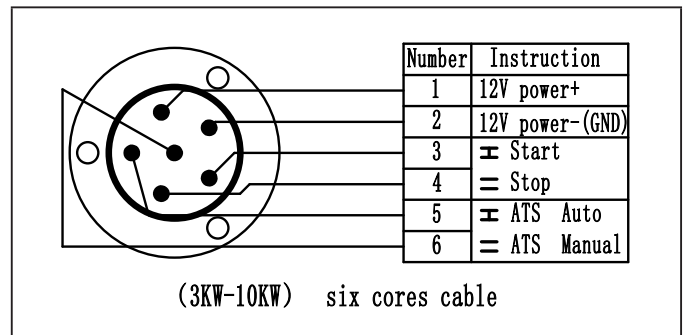

6. Matters need attention!

The voltage at both ends INPUT & OUTPUT of the switch line "L"- "N" should always be between 210 - 250v, otherwise the switch will not work normally.

Poles 1&2 and 3&4 on the communication lead MUST never be reversed, otherwise risk burning or damaging ATS panel and battery.

7. STRUCTURE:

Switch: Controls internal wiring power.

If switch is in Position "I", ATS will Start/Stop automatically when power is lost or restored.

If switch is in position "O", switch is turned off and isolated.

Manual handle: Before using manual mode, switch needs to be in position "O" off and isolated.

Padlock: maintenance only. Turn the switch to "O", turn manual handle to "O", then lift up padlock. Lift up padlock, internal wiring power off, switch and manual handle will no longer work.

**⚠ WARNING**

**HIGH VOLTAGE**

Always isolate the incoming main power supply before opening and entering the ATS panel. Only qualified electrician should open and enter this ATS panel.

Operation indicator: showing the electric power state.

- Position "I" Incoming main city power
- Position "O" Double channel power off,
- Position "II" Standby / Auxiliary power

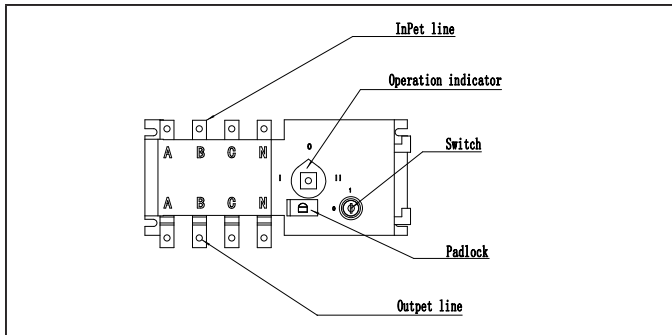

**8. ATS Function:**

When incoming main city power drops or lost, switch turns to Standby / Auxiliary power automatically. When incoming main city power restored, switch returns to incoming main city power .

When both, manual handle in position "O", and switch in position "O", it will turn off and double isolate all channels.

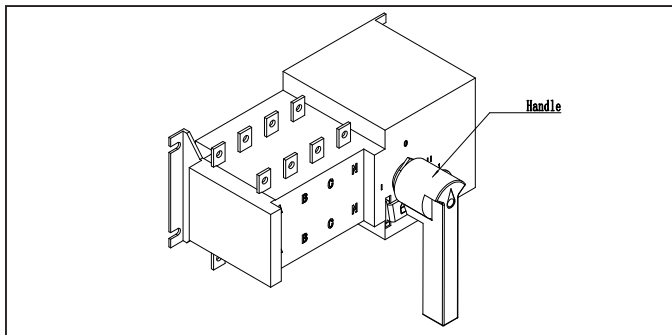

**9. Wiring Drawing**

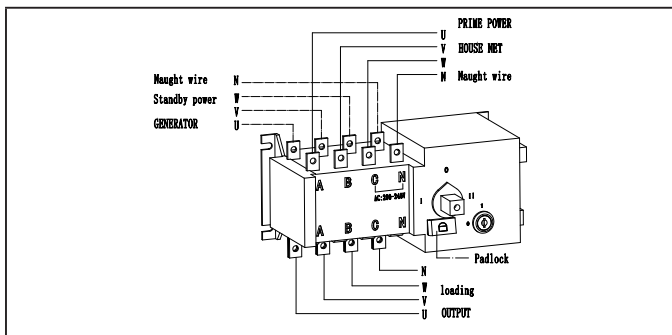

**Eco (Economy) Mode**

The Eco Mode button can be activated to turn on economy control in order to minimize fuel consumption and noise while operating the unit during times of reduced electrical output. Eco Mode allows the engine speed to idle during periods of non-use.

The engine speed returns to normal when an electrical load is connected. When the economy switch is off, the engine runs at normal speed continuously.

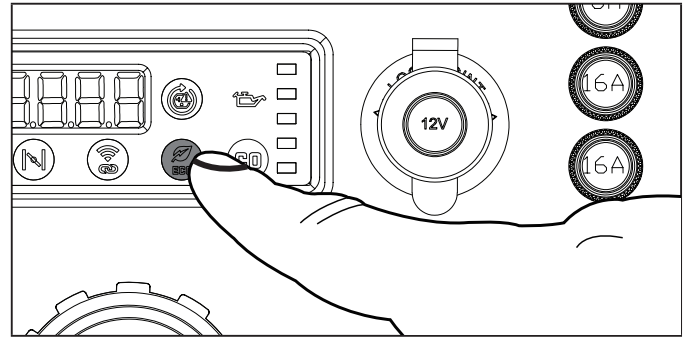

**⚠ CAUTION**

For periods of high electrical load or momentary fluctuations, the Eco Mode should be off.

**12V DC Regulated Automotive Style Outlet**

The 12V DC outlet(s) can be used with supplied accessories and other commercially available 12V DC automotive style plugs. Confirm the input voltage range of your item is at least 12-24V DC.

**⚠ WARNING**

Do not operate a device while it is plugged into the 12V DC outlet. When charging a device, do not place near or on the exhaust side of the generator. Extreme heat caused by exhaust can damage the device and cause a potential fire hazard. Prolonged exposure to engine exhaust can cause serious injury or death.

**Battery Charging**

1. Before connecting the battery charging cable (not included) to a battery that is installed in a vehicle, disconnect the vehicle battery ground cable from the negative (-) battery terminal.
2. Plug the battery charging cable into the 12V DC receptacle of the generator.
3. Connect the red (+) battery charger lead to the red (+) battery terminal.
4. Connect the black (-) battery charger lead to the black (-) battery terminal.
5. Start the generator.

**Important:** The 12V DC outlet is ONLY to be used with supplied accessories and other commercially available 12V DC automotive style plugs. Be sure all electric devices including the lines and plug connections are in good condition before connection to the generator.

### CAUTION

Do Not use both 230v AC and 12v DC at the same time otherwise you could damage the generator or equipment resulting in voiding your warranty.

### WARNING

Do not start the vehicle while the battery charging cable is connected and the generator is running. It will not give the battery a boost of power. The vehicle or the generator may be damaged. Charge only vented wet lead acid batteries. Other types of batteries may burst, causing personal injury or damage.

### NOTICE

Be sure all electric devices including the lines and plug connections are in good condition before connection to the generator.

## Stopping the Engine: No ATS or ATS on Manual Mode

### Manual Stop

1. Turn off and unplug all electrical connected loads. Never start or stop the generator with electrical devices plugged in or turned on.
2. Let the generator run at no-load for several minutes to stabilize internal temperatures of the engine and generator.
3. Press the Start/Stop button.

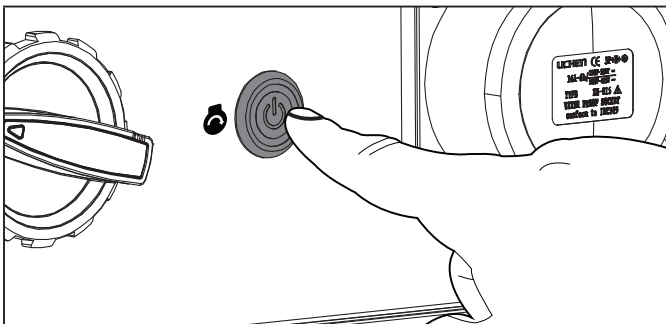

4. Turn the fuel dial to the "OFF" position.

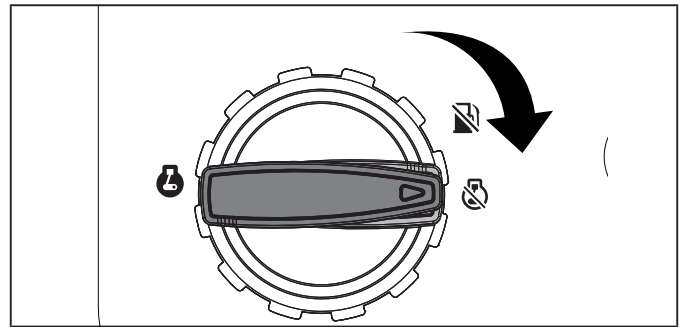

**Important:** Always ensure that the Start/Stop button is "OFF" and not illuminated and fuel valve is in the "OFF" position when the generator will not be used for an extended period of time.

### Remote Stop

1. Press the "STOP" button on the remote.

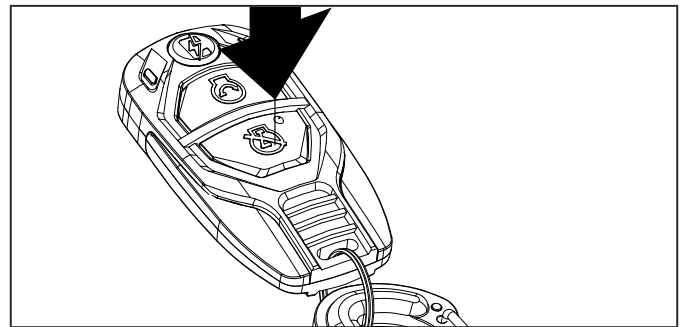

### NOTICE

Engine will shut off but the Start/Stop button will remain in "STANDBY" mode for 24 hours and fuel dial will remain in the "ON" position waiting for the next start instruction.

To completely shut down the generator, make sure the Start/Stop button is in "OFF" mode and no longer flashing green and fuel dial is turned to "OFF" position when the generator will not be used for an extended period of time

### NOTICE

Battery power is drawn while the generator is in standby mode (Start/Stop button flashing green). The generator will stay in standby mode for 24 hours if shut down using the Remote Control. To turn standby mode off manually, push and hold the "STOP" button on the remote control for 5 seconds or push and hold the Start/Stop button on the control panel for 5 seconds. The RCM will no longer consume any battery power or wait for remote signal. This is indicated by the Start/Stop button no longer flashing.

### Stopping the Engine: ATS on Automatic Mode

1. When the mains power is restored, the generator will automatically stop.(Will take approx 20 seconds)

**NOTICE**

If the engine will not be used for a period of two (2) weeks or longer, please see the Storage section for proper engine and fuel storage.

### Moving the Generator

**CAUTION**

- NEVER lift or carry the generator using the folding handle.
- NEVER tilt sideways while moving the generator.
- ALWAYS place the generator on its wheels in the upright position.
- ALWAYS turn the generator off and ensure the fuel valve is closed.
- ALWAYS make sure engine and muffler are cooled down before the generator can be handled safely (typically 15-30 minutes).

**WARNING**

Failure to follow these instructions carefully could result in personal injury or damage to the generator resulting in voiding your warranty

**WARNING**

The folding handle is not long enough to hold and walk with a full stride when moving the generator. Always side step as you walk to avoid injury to your heels and/or feet. Failure to follow these instructions could result in personal injury or damage to the generator.

1. Begin by raising the folding handle, found on opposite side of wheels.
2. Using the handle, tilt the end of the generator slightly off the ground until balanced on the wheels.

3. While maintaining balance, roll the generator to the desired location.

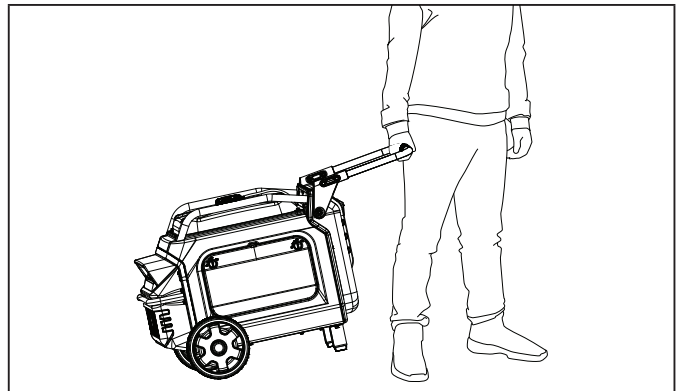

### Operation at High Altitude

The density of air at high altitudes is lower than at sea level. Engine power is reduced as the air mass and air-fuel ratio decrease. Engine power and generator output will be reduced approximately 3½% for every 1000 ft. of elevation above sea level. At high altitudes increased exhaust emissions can also result due to the increased enrichment of the air fuel ratio. Other high altitude issues can include hard starting, increased fuel consumption and spark plug fouling.

To alleviate high altitude issues other than the natural power loss, CPE can provide a high altitude carburetor main jet. The alternative main jet and installation instructions can be obtained by contacting our Technical Support Team. Installation instructions are also available in the Technical Bulletin area of the CPE website.

The part number and recommended altitude range for the application of the high altitude carburetor main jet is listed in the following table.

In order to select the correct high altitude main jet it is necessary to identify the carburetor model. For this purpose, a code is stamped on the side of the carburetor. Select the correct high altitude jet part number corresponding to the carburetor code found on your particular carburetor.

Carb. Code	High Alt. Jet Part Number	Altitude Range
16100-000023	16161-000058	3000ft. (914m)
	16161-000007	6000ft. (1829 m)

**⚠ WARNING**

Operation using the alternative main jet at elevations lower than the recommended minimum altitude can damage the engine. For operation at lower elevations, the originally supplied standard main jet must be used. Operating the engine with the wrong engine configuration at a given altitude may increase its emissions and decrease fuel efficiency and performance.

**MAINTENANCE**

Make certain that the generator is kept clean and stored properly. Only operate the unit on a flat, level surface in a clean, dry operating environment. DO NOT expose the unit to extreme conditions, excessive dust, dirt, moisture or corrosive vapors.

**⚠ WARNING**

Never operate a damaged or defective generator.

**⚠ WARNING**

Your generator needs regular servicing and maintenance, failure to properly maintain and service your generator regularly will result in voiding any warranty. For clear guidance read and understand this section.

**🗨 NOTICE**

For Emission control devices and systems, read and understand your responsibilities for service as stated in the Emission Control Warranty Statement of this manual.

The owner/operator is responsible for all periodic servicing and maintenance.

Complete all scheduled maintenance in a timely manner.

Correct any issue before operating the generator.

**Cleaning the Generator****⚠ CAUTION**

DO NOT spray, jet, power wash generator directly with water.

Water can enter the generator through the cooling slots and damage the generator windings. It can also contaminate the fuel system.

1. Use a damp cloth to clean exterior surfaces of the generator.
2. Use a soft bristle brush to remove dirt and oil.

3. Use an air compressor (25 PSI) to clear dirt and debris from the generator.
4. Inspect all air vents and cooling slots to ensure that they are clean and unobstructed.

To prevent accidental starting, remove and ground the spark plug wire before performing any service.

**Changing the Engine Oil**

Recommended every 100 hours or annually Change oil when the engine is warm. Refer to the oil specification to select the proper grade for your operating environment.

1. Place the generator on a flat level surface.
2. Loosen the two cover screws and remove the maintenance cover.

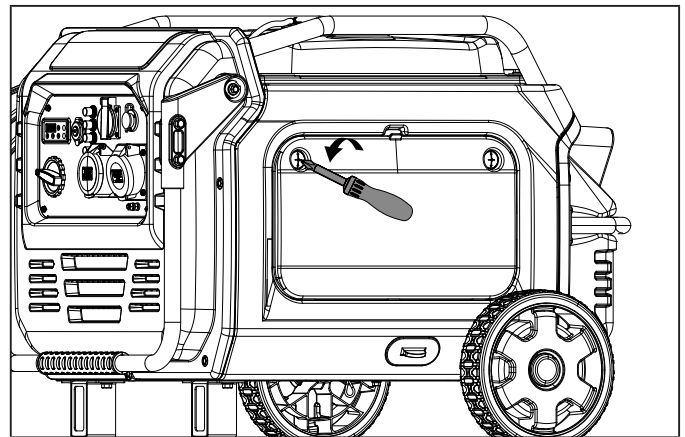

3. Remove the oil drain hose slot plug and pull the drain hose through the slot.

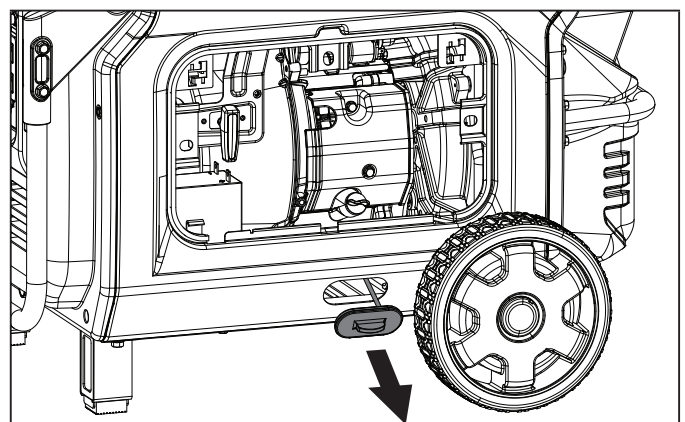



- Remove the oil drain plug by turning it counter clockwise.

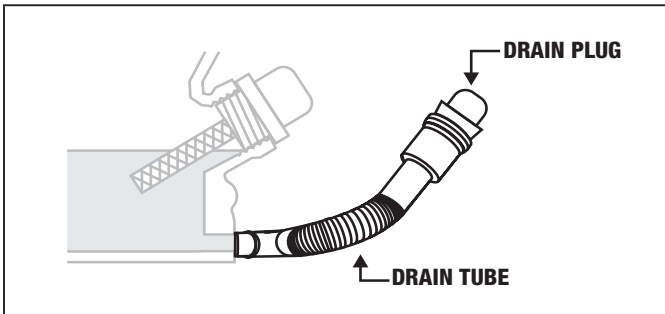

- Ensure the oil drain hose is lower than the engine and allow the oil to drain completely into an appropriate container.

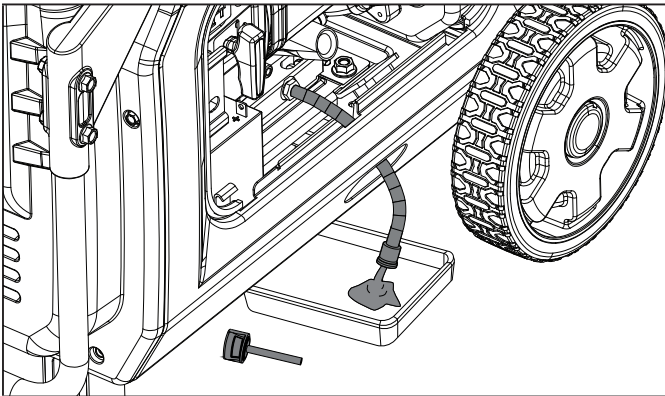

- Replace the oil drain plug.
- Add oil according to *Add Engine Oil in Assembly* section. Recommended 10W30 DO NOT OVERFILL. Oil not included for routine maintenance.
- Reinstall the maintenance cover.
- Dispose of used oil at an approved waste management facility.

### NOTICE

Once oil has been added, on flat level surface as a general rule oil should be visible about 1-2 threads from top of the oil port hole. If using the dipstick to check oil level, DO NOT screw in the dipstick while checking simply rest it against the top of the port and take reading.

## Cleaning and Adjusting the Spark Plug

- Loosen the two cover screws and remove the maintenance cover.

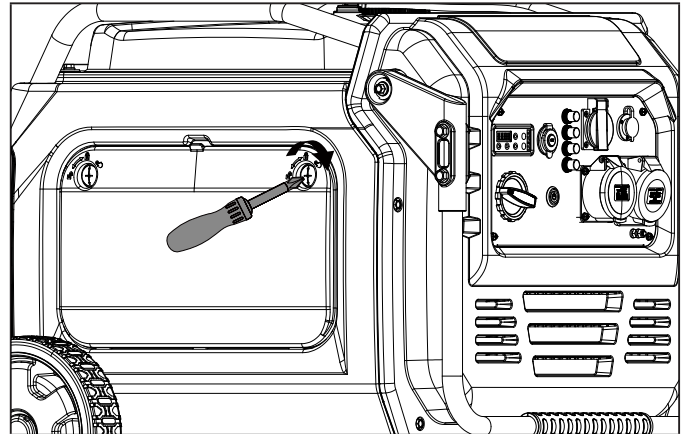

- Remove the spark plug cable from the spark plug.

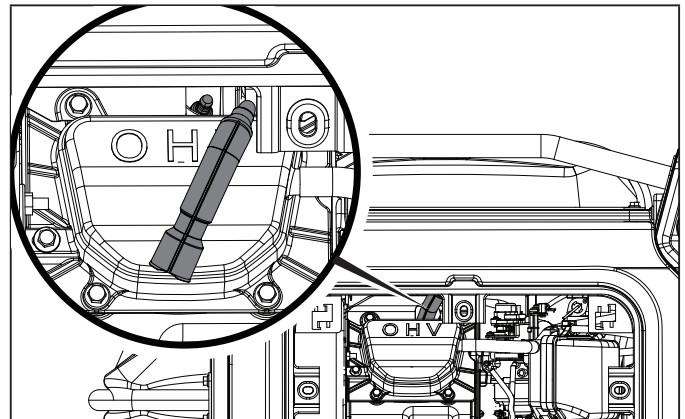

- Use a spark plug socket tool (included), or a 13/16 in. (21 mm) socket (not included) to remove the plug.
- Inspect the electrode on the plug. It must be clean and not worn to produce the spark required for ignition.
- Make certain the spark plug gap is 0.028-0.031 in. (0.7-0.8 mm).

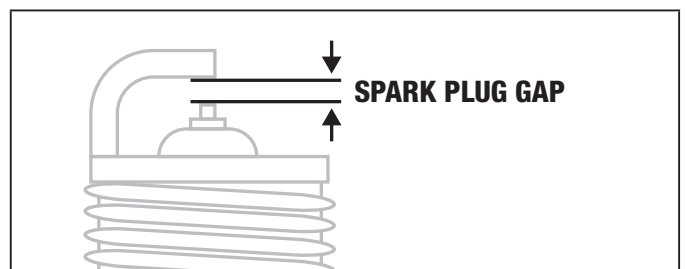

- Refer to the spark plug types in Specifications when replacing the plug.
- Firmly re-install the plug.
- Attach the spark plug cable to the spark plug.
- Reinstall the maintenance cover.

## Cleaning the Air Filter

1. Loosen the two cover screws and remove the maintenance cover.

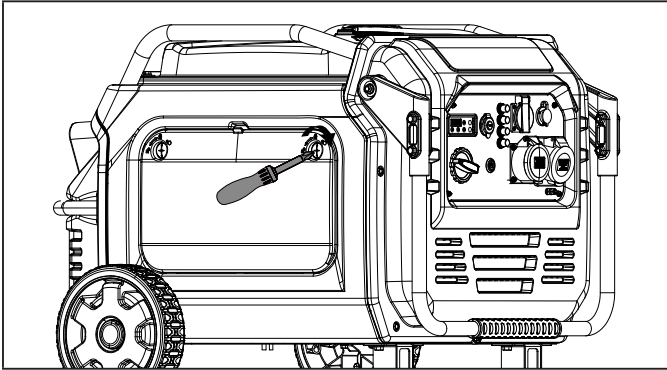

2. Locate the air filter plastic cover and remove by pinching the clips together and pulling the cover off.

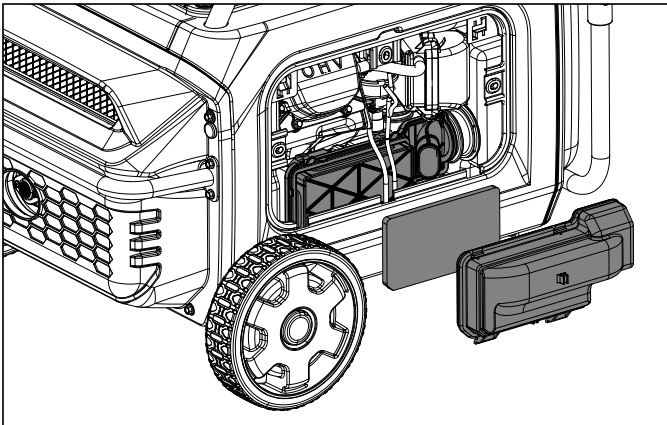

3. Remove the foam element.
4. Wash in liquid detergent and water. Squeeze thoroughly dry in a clean cloth.
5. Saturate in clean engine oil.
6. Squeeze in a clean, absorbent cloth to remove all excess oil.
7. Place the filter in the assembly.
8. Re-install the maintenance cover.

## Cleaning the Spark Arrestor

1. Recommended every 50 hours use or annually. Allow the engine to cool completely before servicing the spark arrestor.
2. Remove the two screws holding the cover plate which retains the spark arrestor to the muffler.
3. Remove the spark arrestor screen.

4. Carefully remove the carbon deposits from the spark arrestor screen with a wire brush.

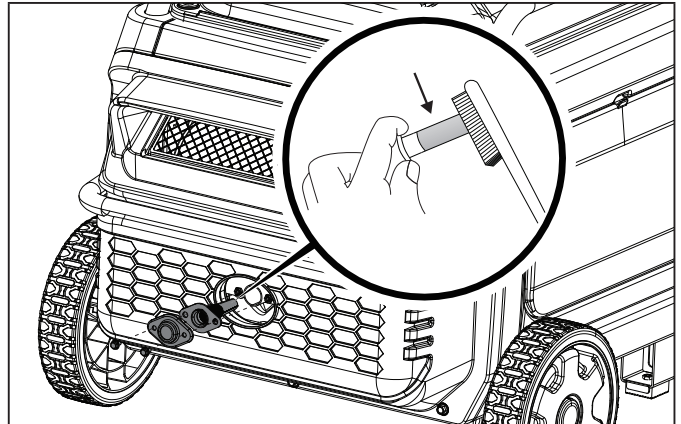

5. Replace the spark arrestor if it is damaged.
6. Position the spark arrestor on the muffler and attach with the screws removed in step 2.

### CAUTION

Failure to clean the spark arrestor regularly will result in degraded engine performance and may damage engine resulting in voiding any warranty.

### NOTICE

Federal and local laws and administrative requirements indicate when and where spark arrestors are required. When ordered, spark arrestors are required for operation of this generator in National Forest lands. In California, this generator must not be used on any forest-covered land, brush-covered land, or grass-covered land unless the engine is equipped with a spark arrestor.

## Adjusting the Governor

### WARNING

Tampering with the factory set governor will void your warranty.

The air-fuel mixture is not adjustable. Tampering with the governor can damage your generator and your electrical devices and will void your warranty.

## Generator Battery

Your generator is equipped with an automatic battery charging circuit that charges the battery while the engine is running. The battery will maintain a proper charge if the unit is used at least once every 180 days for 2 hours with ECO mode off. If it is used less frequently, the battery should be connected to a trickle charger or battery maintainer (not included) to keep the battery properly charged.

Maximum charging rate should not exceed 1.6 amps. Follow the instructions included with the battery charger. The battery should be fully charged at least twice per year. If the battery is not able to start the engine, it can be started by manually pulling the engine recoil cord. If the battery voltage is extremely low, the charging circuit may not be able to re-charge the battery. In this case, the battery must be connected to a standard automotive style battery charger for re-charging before it can be used.

### Disconnect the Battery

1. Pull two halves of battery connector apart.

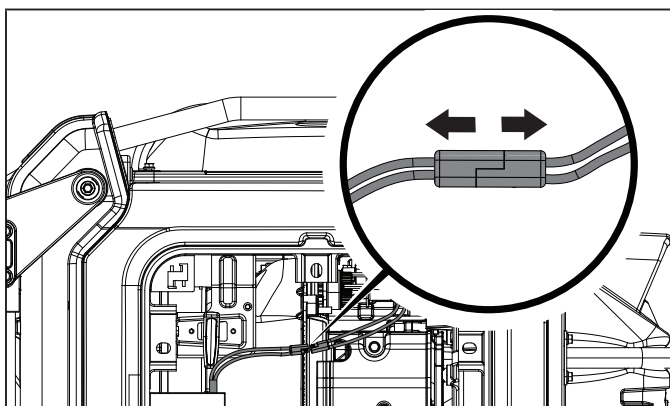

### Charge the Battery

For a generator equipped with batteries for electric starting, proper battery maintenance and storage should be followed. A trickle charger or battery maintainer should be used to charge the battery while the generator is in storage. Maximum charging rate should not exceed 1.6 amps. Follow the instructions included with the trickle charger or battery maintainer. The battery should be fully charged at least once per month.

1. Remove the battery from the generator.
2. Charge battery following the battery charger's instructions.
3. After charging, leave the battery for 0.5 to 1 hour before checking the voltage. If the voltage is less than 12.8 volts, additional charging is necessary.

### WARNING

Electrolyte inside the battery is harmful to skin and eyes. Electrolyte may pose an increased risk of harm if not handled properly.

If the battery leaks and electrolyte gets in your eyes, do not rub them. Instead, rinse them with clean running water and immediately seek medical attention. If left untreated, electrolyte can cause permanent eye injury. Keep away from children.

### NOTICE

- Do not charge the battery with charging voltage over 15.0V and charging current over 1.6A.
- Do not charge the battery below 32°F (0°C) or above 113°F (45°C).
- If the battery becomes hot to the touch, stop charging. Allow battery to cool before resuming.

## Remote Key Fob Transmitter Battery

### NOTICE

- Always purchase the correct size and grade of battery most suitable for the intended use.
- Clean the battery contacts and also those of the device prior to battery installation.
- Remove batteries from equipment which is not to be used for an extended period of time.
- Remove batteries if consumed or if product is to be left unused for a long time.

1. Remove the remote key fob from the key ring.
2. Remove the screw with a Phillips screwdriver (not included) by turning counter clockwise.
3. Pry the two halves of the remote key fob apart slightly at the key ring end.
4. Separate the two halves of the remote key fob by sliding the back side of the remote key fob up toward the key ring end.

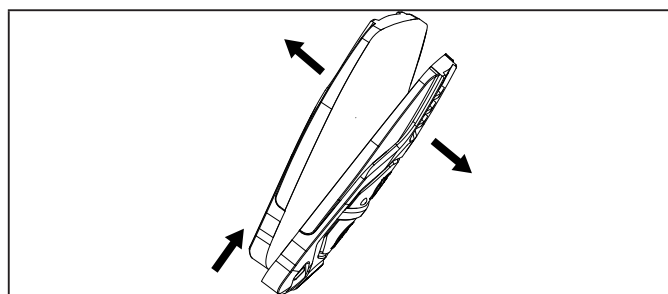

5. Carefully remove the circuit board to locate and replace the CR2016 battery.
6. Reverse the above instructions to reassemble the remote key fob.



## Maintenance Schedule

Follow the service intervals indicated in the following maintenance schedule.

Service your generator more frequently when operating in adverse conditions.

### EVERY 8 HOURS OR PRIOR TO EACH USE

- Check oil level
- Clean around air intake and muffler

### FIRST 5 HOURS (BREAK IN)

- Change oil

### EVERY 50 HOURS OR ANNUALLY

- Clean air filter
- Change oil if operating under heavy load or in hot environments

### EVERY 100 HOURS OR ANNUALLY

- Change oil
- Clean/adjust spark plug
- Clean spark arrestor
- Clean fuel valve filter\*

### EVERY 250 HOURS

- Clean combustion chamber\*
- Check/adjust valve clearance\*

### EVERY 3 YEARS

- Replace fuel line\*

\*To be performed by knowledgeable, experienced owners or CPE certified service centers.

## STORAGE

### WARNING

To avoid accidental or unintended ignition of your generator during periods of storage, the following precautions should be followed:

- When storing the generator make sure the EZ Start dial is set to the “OFF” position.

### Short to Mid Term Storage (up to 1 year)

Petrol in the fuel tank has a maximum shelf life of up to 1 year with the addition of properly formulated fuel stabilizers and if stored in a cool, dry place. Petrol in the carburetor, however, may gum up and clog the carburetor if it isn't used or drained within 2-4 weeks.

If using the generator within 2 weeks, follow the steps according to *Stopping the Engine* section.

1. If not using the generator for more than 2 weeks, begin by making sure all appliances are disconnected from the generator.
2. Add a properly formulated fuel stabilizer to the fuel tank.
3. Start engine by following directions in the *Starting the Engine* section.
4. Run the generator for 10 minutes so the treated petrol cycles through the fuel system and carburetor.
5. Turn the fuel dial to the “STOP” position.
6. After the engine has stopped, allow the engine to cool.
7. Remove the maintenance cover opposite the oil drain side.
8. Remove the spark plug and pour about a tablespoon of oil into the cylinder.
9. SLOWLY pull the recoil to rotate the engine to distribute and lubricate the cylinder.
10. Re-install the spark plug and spark plug wire.
11. Re-install the maintenance cover.
12. Clean the generator according to *Cleaning the Generator*.
13. Store the generator in a cool, dry place out of direct sunlight.

### Long Term Storage (more than 1 year)

For storage over 1 year, the fuel tank and carburetor must be completely drained of petrol.

1. Be sure all appliances are disconnected from generator.
2. Place inverter on blocks to allow appropriate petrol container or pan to slide under inverter.
3. Remove the maintenance cover opposite the oil drain side.
4. Turn the fuel dial to the full “RUN” position.

- Using a flat head screwdriver (not included), rotate drain screw counterclockwise (3) full turns. Petrol will drain through clear tubing out underneath the inverter. Make sure draining petrol empties into an appropriate container.

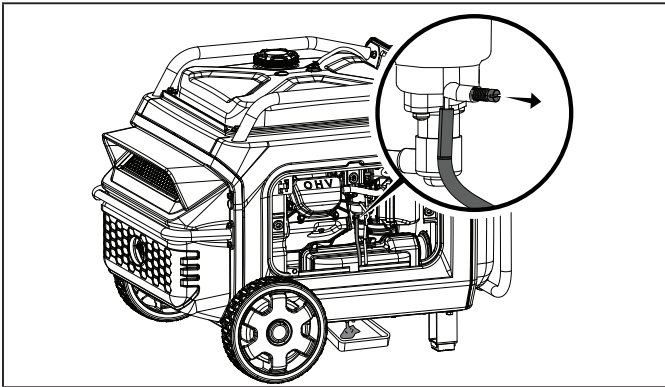

- When petrol stops flowing from the clear tube, rotate drain screw clockwise until tight. Properly dispose of the drained petrol according to local regulations or guidelines.
- Turn the fuel dial to the “STOP” position.
- Follow steps 7-13 according to *Short to Mid Term Storage*.

## Removing from Storage

### NOTICE

If the generator has been improperly stored for a period longer than 30 days with ethanol blended gasoline in the petrol tank and/or carburetor, all fuel must be drained and the carburetor must be thoroughly cleaned of ethanol build up. This process involves technically advanced tasks.

If the fuel tank and carburetor were properly emptied of all ethanol blended petrol prior to the generator being stored, follow the below steps when removing from storage.

- Be sure the fuel dial is in the “STOP” position.
- Add petrol to the generator according to *Add Fuel*.
- Move the fuel dial to the “RUN” position.
- After 5 minutes check the carburetor and air filter areas for any leaking petrol. If any leaks are found, the carburetor will need to be disassembled and cleaned or replaced. If no petrol leaks are found, turn the fuel dial to the “STOP” position.
- Check engine oil level and add clean, fresh oil if needed. See *Oil Specifications* for proper oil type.
- Check and clear air filter of any obstructions such as bugs or cobwebs. If necessary, clean air filter according to *Cleaning the Air Filter*.
- Start the generator according to *Starting the Engine*.

# SPECIFICATIONS

## Generator Specifications

Generator Model .....	97001i-P-UK
Start Type .....	Electric, Manual, Wireless
Watts (Max/Running) .....	7500/7000
AC Volts .....	240
AC Amps @ 240V (Running) .....	29.2
Volts DC .....	12
DC Amps .....	8
Frequency .....	50 Hz
Phase .....	Single
Grounding Type .....	Neutral Floating
Weight .....	212.8 lb. (96.5 kg)
Length .....	33.4 in. (84.8 cm)
Width .....	29.1 in. (74.0 cm)
Height .....	26.0 in. (66.1 cm)
Max site altitude of installation .....	1000 m
Measured sound pressure level (7m) .....	61 dB(A)
Measured sound pressure level (4m) .....	74 dB(A)
Noise measurement uncertainty .....	≤1.56 dB(A)
Guaranteed sound power level .....	96 dB(A)

## Engine Specifications

Model .....	R420-V
Displacement .....	420 cc
Type .....	4-Stroke OHV

### Spark Plug

OEM Type .....	F7RTC
Replacement Type .....	NGK BPR7HS or equivalent
Gap .....	0.028-0.031 in. (0.7-0.8 mm)

### Valve

Intake Clearance .....	0.002-0.006 in. (0.05-0.15 mm)
Exhaust Clearance .....	0.002-0.006 in. (0.05-0.15 mm)

**NOTICE**

A technical bulletin regarding valve adjustment procedures is available at [www.championpowerequipment.co.uk](http://www.championpowerequipment.co.uk).

## Oil Specifications

DO NOT OVERFILL.

Type .....	*See following chart
Capacity .....	37.2 fl. oz. (1100 ml)

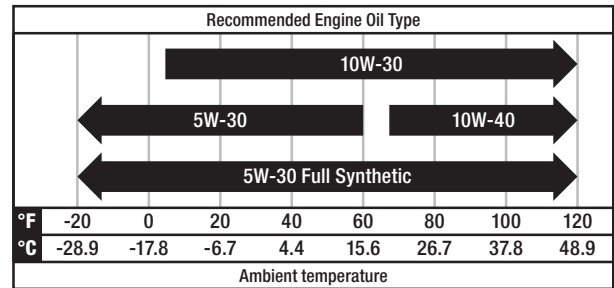

**NOTICE**

Temperature will affect engine oil and engine performance. Change the type of engine oil used based on temperature shown in the "Recommended Engine Oil Type" table.

## Fuel Specifications <sup>E5</sup> <sup>E10</sup>

Use unleaded petrol with a minimum octane rating of 85 and an ethanol content of 10% or less by volume. DO NOT USE E15 or E85. DO NOT OVERFILL.

Fuel Capacity .....	5.33 gal. (20.20 L)
---------------------	---------------------

## Battery Specifications

Type .....	Rechargeable, Non-Spillable Lead Acid
Volts DC .....	12
Capacity .....	9 Ah

## Temperature Specifications

Starting Temperature Range (°F/°C) .....	5 to 104/-15 to 40
--	--------------------

**NOTICE**

**An important message about temperature:** Your product is designed and rated for continuous operation at ambient temperatures up to 104°F (40°C). When needed, it may be operated at temperatures ranging from 5°F (-15°C) to 122°F (50°C) for short periods of time. If exposed to temperatures outside this range during storage, it should be brought back within this range before operation. In any event, the product must always be operated outdoors, in a well-ventilated area and away from doors, windows and vents.

Figure A Parts Diagram

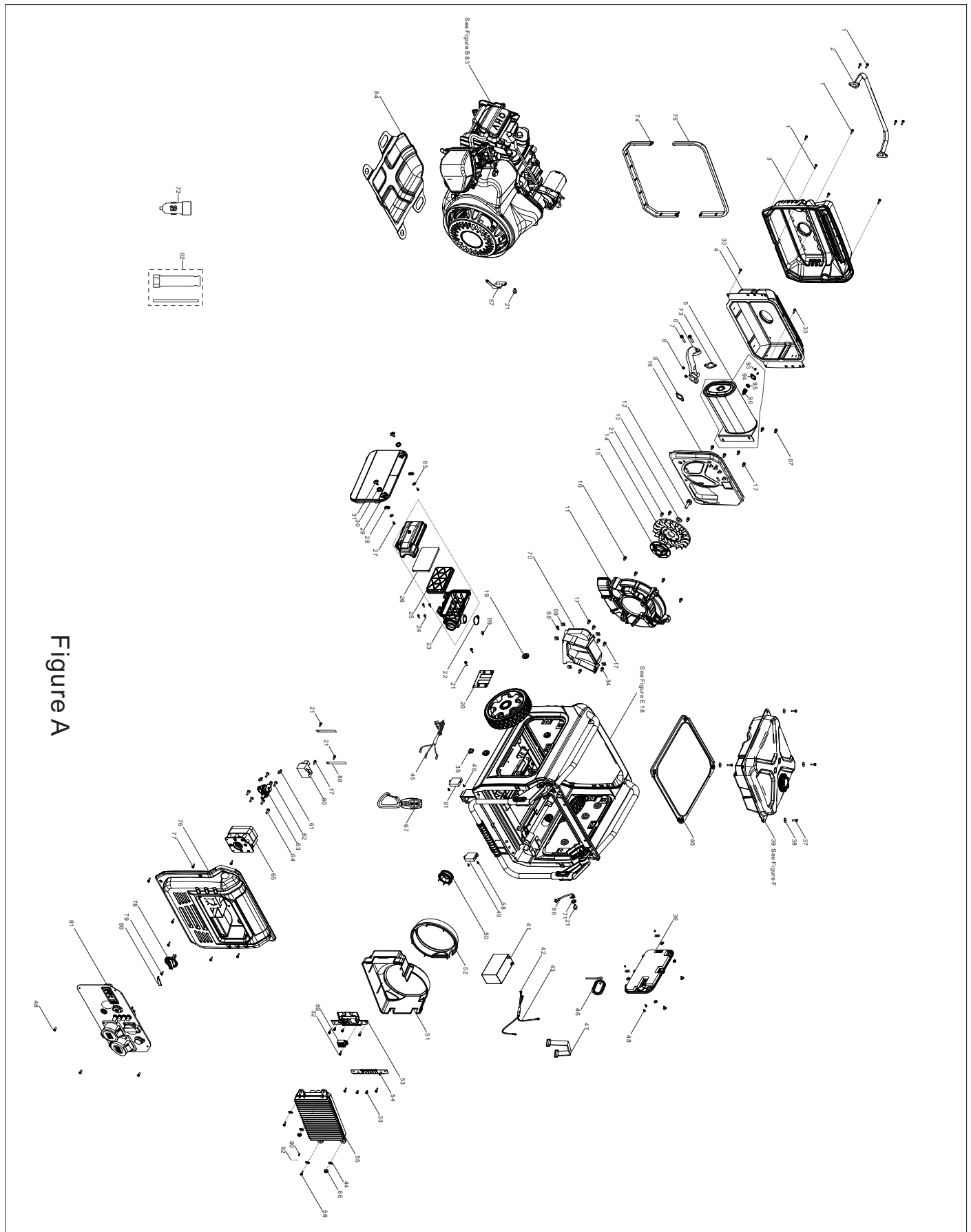

## Figure A Part List

#	Part Number	Description	Qty.
1	90001-000027	Hexagon Flange Bolt, M6 x 25, Black Zinc	9
2	51001-000001	Crossbar Tube, Ø25	1
3	16673-000002	Shield, Muffler Protection	1
4	18130-000004	Muffler Guard	1
5	18100-000045	Muffler Assembly	1
6	18150-000001	Exhaust Pipe, Muffler	1
7	90001-000062	Hexagon Flange Bolt, M8 x 40	2
8	90303-000004	Nut, M8, Black Zinc	2
9	18001-000004	Exhaust Outlet Gasket	1
10	90001-000044	Hexagon Flange Bolt, M8 x 25, White Zinc	4
11	28110-000002	Shroud, Crankcase Cover	1
12	90002-000001	Hexagon Flange Bolt, M10 x 30, White Zinc	1
13	90408-000011	Flat Washer, White Zinc	1
14	19352-000004	Cooling Fan, Inverter	1
15	13515-000001	Mounting disc, Cooling Fan, Ø20 x Ø89 x 3.5	1
16	18003-000002	Muffler Guard, Inner	1
17	90001-000022	Hexagon Flange Bolt, M6 x 16, White Zinc	8
18	96103-Y51100-0008	Frame Assembly - See Figure E	1
19	16601-000005	Rubber sleeve, Access Panel	6
20	17003-000007	Air Cleaner Support	1
21	90001-000018	Hexagon Flange Bolt, M6 x 12, White Zinc	11
22	12081-000002	Clamp, Inlet Tube, M6x15	1
23	17100-000018	Air Cleaner	1
24	17150-000003	Element Assembly, Air Cleaner	1
25	17151-000006	Element, Air Cleaner	1
26	90001-000024	Hexagon Flange Bolt, M6 x 20, White Zinc	4
27	90124-000002	Self Tapping Screw, PT4x13	4
28	24329-000003	Block	4
29	80092-000026	Access Panel, Left	1
30	16527-000002	Spring, Stopper Adjusting, Ø1.2 x Ø15.3 x 13	4
31	35643-000005	Knob, Access Panel	4
32	90007-000011	Hexagon Flange Bolt, M6 x 16, White Zinc	1
33	90007-000008	Hexagon Flange Bolt, M6 x 12, Black Zinc	10
34	90007-000004	Hexagon Flange Bolt, M5 x 16, White Zinc	4
35	90804-000004	Limit Plate, Fuel Drain Tube	1
36	80096-000025	Access Panel, Right	1
37	90001-000031	Hexagon Flange Bolt, M6 x 30, Black Zinc	4
38	90408-000024	Flat Washer, Ø6 x Ø32 x 1.5, Black Zinc	4
39	96104-Y16620-0007	Fuel Tank Assembly - See Figure F	1
40	35671-000002	Waterproof Strip	1

#	Part Number	Description	Qty.
41	31110-000007	Battery, 12V/9Ah, 150 x 65 x 90	1
42	31112-000004	DC Wire Harness, Battery	1
43	31114-000005	DC Wire Harness, Engine	1
44	90401-000001	Washer, Ø6.5 x Ø25 x 2	4
45	90805-000001	Connecting wires, Remote Controller	1
46	90722-000008	Plug, End	1
47	31115-000001	Strap, Battery	1
48	90103-000012	Screw, M5 x 12, Black Zinc	8
49	35720-000003	CO Alarm	1
50	17006-000001	Air Cleaner cushion	1
51	30041-000002	Inverter Cover	1
52	30214-000001	Gasket, Inverter Cover	1
53	30081-000012	Inverter, Bracket 1	1
54	30081-000013	Inverter, Bracket 2	1
55	30043-000030	Inverter, 6.8/7.5kW 120V/240V 60Hz	1
56	90007-000013	Hexagon Flange Bolt, M6 x 20, White Zinc	2
57	31303-000003	Terminal Block, White Zinc	1
58	90103-000012	Screw, M5 x 12, Black Zinc	2
59	30060-000021	Rectifier	1
60	30007-000002	Charger Module, EC0803	1
61	90685-000013	Clamp, Ø8.5 x 0.6 x 8	2
62	90255-000001	Screw & Washer Assembly, M4 x 10, White Zinc	2
63	16750-000010	Fuel Switch	1
64	90129-000002	Self Tapping Tcrew, ST4.2x16, White Zinc	4
65	35160-000018	Switch, Engine	1
66	90305-000005	Hexagon Flange Nut, M6, White Zinc	2
67	39024-000004	Remote Key	1
68	90007-000006	Hexagon Flange Bolt, M5 x 20, White Zinc	1
69	17199-000003	Clip Nut, M5, White Zinc	5
70	28110-000036	Shroud, Muffler Guard	1
71	90415-000001	Lock Washer, Toothed, Black Zinc	1
72	35613-000001	12VDC USB Adapter	1
73	18001-000005	Exhaust Outlet Gasket	1
74	18005-000004	Heat Insulation rubber, muffler inner cover, Down	1
75	18005-000003	Heat Insulation rubber, muffler inner cover, Up	1
76	35680-000010	Control Panel Housing	1
77	90001-000023	Hexagon Flange Bolt, M6 x 16, Black Zinc	7
78	35643-000006	Switch Dial, Engine	1
79	90103-000006	Screw, M4 x 16, White Zinc	1
80	82007-000005	Decorative Cover	1

#	Part Number	Description	Qty.
81	35610-000154	Control Panel Assembly - See Figure G	1
82	93130-000001	Spark Plug Socket	1
83	96100-R420DVI0-03	Engine, 420cc	1
84	19306-000003	Crankcase Air Deflector	1
85	90408-000002	Flat Washer	4
86	30009-000019	Grounding Wire	1
87	90001-000041	Hexagon Flange Bolt, M8 x 16, Black Zinc	2
88	90684-000001	Clip, L=100	2
89	90685-000002	Clamp, Ø9 x 0.8 x 8	1
90	90007-000026	Hexagon Flange Bolt, M5 x 8, White Zinc	1
91	39027-000003	Remote Module	1
92	90684-000001	Clip, L=130	1
93	90139-000001	Hexagon Bolt, M5×10, White Zinc	2
94	94111-000011	Flange Pite, Spark Arrestor	1
95	18218-000003	Sound Absorbing Block	1
96	18250-000013	Spark Arrestor	1

Figure B Engine Parts Diagram

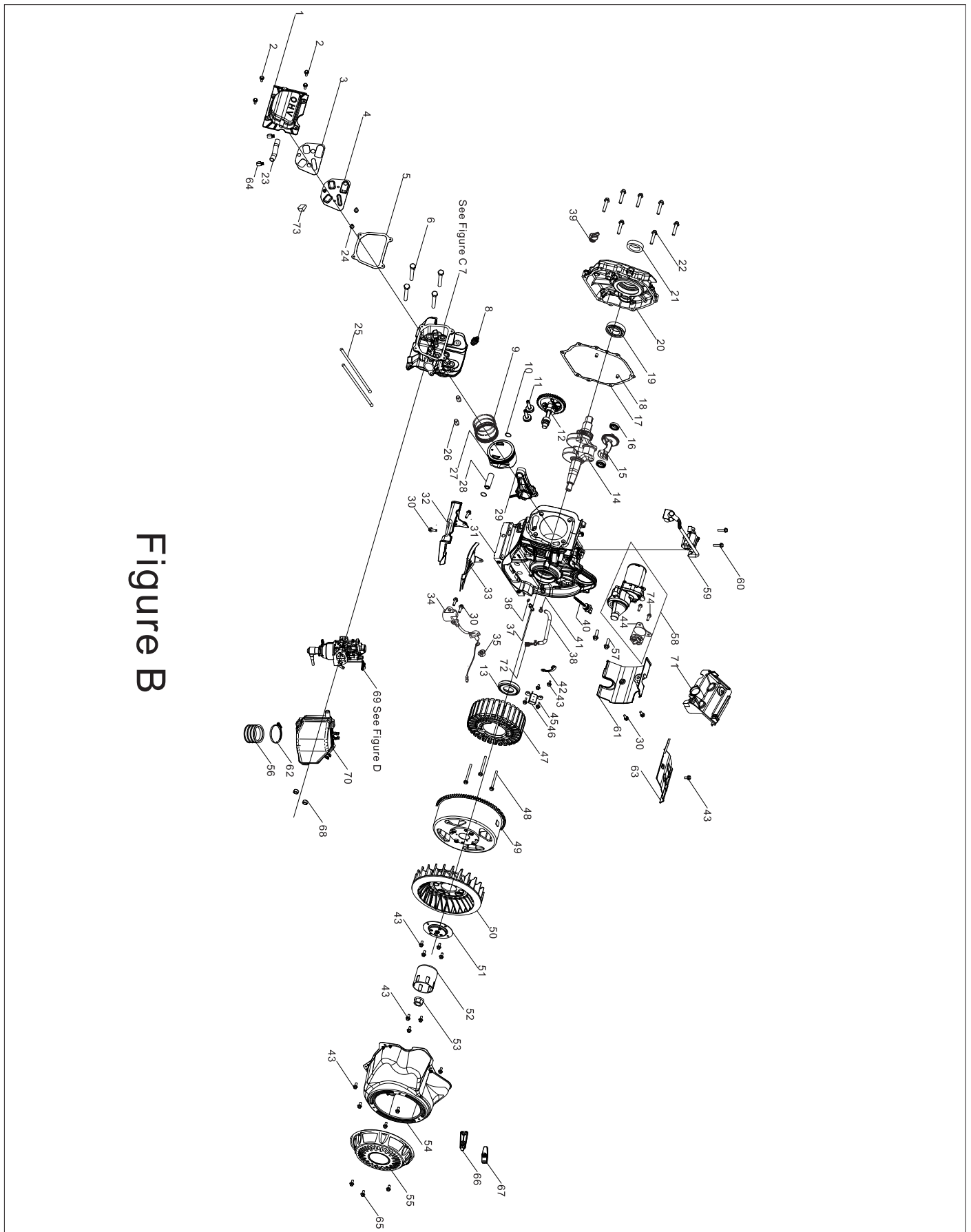

Figure B



## Figure B Engine Part List

#	Part Number	Description	Qty.
1	12410-000007	Cylinder Head Cover Subassembly	1
2	90001-000024	Hexagon Flange Bolt, M6 x 20, White Zinc	4
3	11332-000002	Gasket, Breather Groove Cover	1
4	11320-000003	Breather	1
5	12004-000011	Cylinder Head Cover Gasket	1
6	12003-000004	Cylinder Head Bolt, M10 x 80, White Zinc	4
7	96101-Z120410-0009	Cylinder Head Assembly - See Figure C	1
8	30010-000003	Spark Plug, F7RTC	1
9	13200-000015	Piston Ring Assembly	1
10	13122-000002	Piston Pin Clip	2
11	14081-000003	Valve Tappet	2
12	14200-000007	Camshaft Assembly	1
13	90682-000005	Oil Seal, Ø40 x Ø52 x 9	1
14	13300-000013	Crankshaft Assembly	1
15	13400-000001	Balancing Shaft	1
16	90548-000001	Bearing, 6202	2
17	11001-000004	Crankcase Gasket	1
18	90502-000002	Pin, 8 x 12	2
19	90547-000009	Bearing, 6207	1
20	11411-000007	Crankcase Cover	1
21	90682-000006	Oil Seal, Ø35 x Ø52 x 7	1
22	90001-000050	Hexagon Flange Bolt, M8 x 40, White Zinc	7
23	17004-000015	Tube, Breather	1
24	90001-000003	Hexagon Flange Bolt, M5 x 12, White Zinc	2
25	14070-000002	Valve Lifter	2
26	90502-000008	Pin, 12 x 20	2
27	13111-000020	Piston	1
28	13121-000004	Piston Pin, Ø20 x Ø14.75 x 62	1
29	13010-000004	Connecting Rod	1
30	90001-000022	Hexagon Flange Bolt, M6 x 16, White Zinc	6
31	11310-000008	Crankcase Subassembly	1
32	19305-000002	Cylinder Body Shroud 2	1
33	12014-000001	Head Air Deflector 1	1
34	37060-000006	Engine oil Sensor, W/O Nut	1
35	90305-000014	Hexagon Flange Nut, M10, White Zinc	1
36	90408-000021	Flat Washer, Ø15.8	1
37	90689-000003	Connector, M10-1.25, Fuel Tube	1
38	11011-000003	Oil Drain Hose Assembly	1
39	15030-000001	Oil Plug Subassembly	1
40	15010-000005	Oil Dipstick Subassembly	1
41	90685-000004	Clamp, Ø16 x 0.8 x 10	2

#	Part Number	Description	Qty.
42	30002-000002	Magneto Wiring Clamp	1
43	90001-000018	Hexagon Flange Bolt, M6 x 12, White Zinc	15
44	30500-000001	Starting Relay	1
45	90001-000007	Hexagon Flange Bolt, M5 x 16, White Zinc	2
46	30130-000005	Trigger Assembly	1
47	30120-000033	Stator Component, Ø179 x 53	1
48	90007-000020	Hexagon Flange Bolt, M6 x 65, White Zinc	3
49	30110-000008	Rotor Component, Ø179 x 53	1
50	19352-000015	Cooling Fan, Engine	1
51	28020-000001	Starter Pulley Base	1
52	28002-000010	Starter Pulley, White Zinc	1
53	13501-000002	Flywheel Nut, M16 x 1.5, White Zinc	1
54	28110-000015	Shroud	1
55	28200-000015	Recoil Starter Assembly	1
56	12510-000002	Inlet Tube	1
57	90001-000044	Hexagon Flange Bolt, M8 x 25, White Zinc	2
58	30300-000008	Motor Assembly, Starting	1
59	30400-000036	Ignition Coil	1
60	90001-000026	Hexagon Flange Bolt, M6 x 25, White Zinc	2
61	19351-000001	Rear Shield, Crankcase	1
62	12081-000002	Clamp, Inlet Tube	1
63	28118-000003	Block	1
64	90685-000015	Clamp, Ø10.5, White Zinc	2
65	90001-000014	Hexagon Flange Bolt, M6 x 8, Black Zinc	3
66	28004-000003	Guide plate combination, Start Pull Rope	1
67	28210-000002	Start Pull Handle	1
68	90305-000007	Hexagon Flange Nut, M6, White Zinc	2
69	96003-Z16100-0036	Carburetor Assembly - See Figure D	1
70	17400-000003	Secondary Air Cleaner	1
71	12014-000005	Head Air Deflector 2	1
72	90689-000002	Connector, M18-2.5, Fuel Tube	1
73	11331-000002	Filter, Breath Groove Cover	1
74	90001-000007	Hexagon Flange Bolt, M5 x 16, White Zinc	2



Figure C Parts Diagram

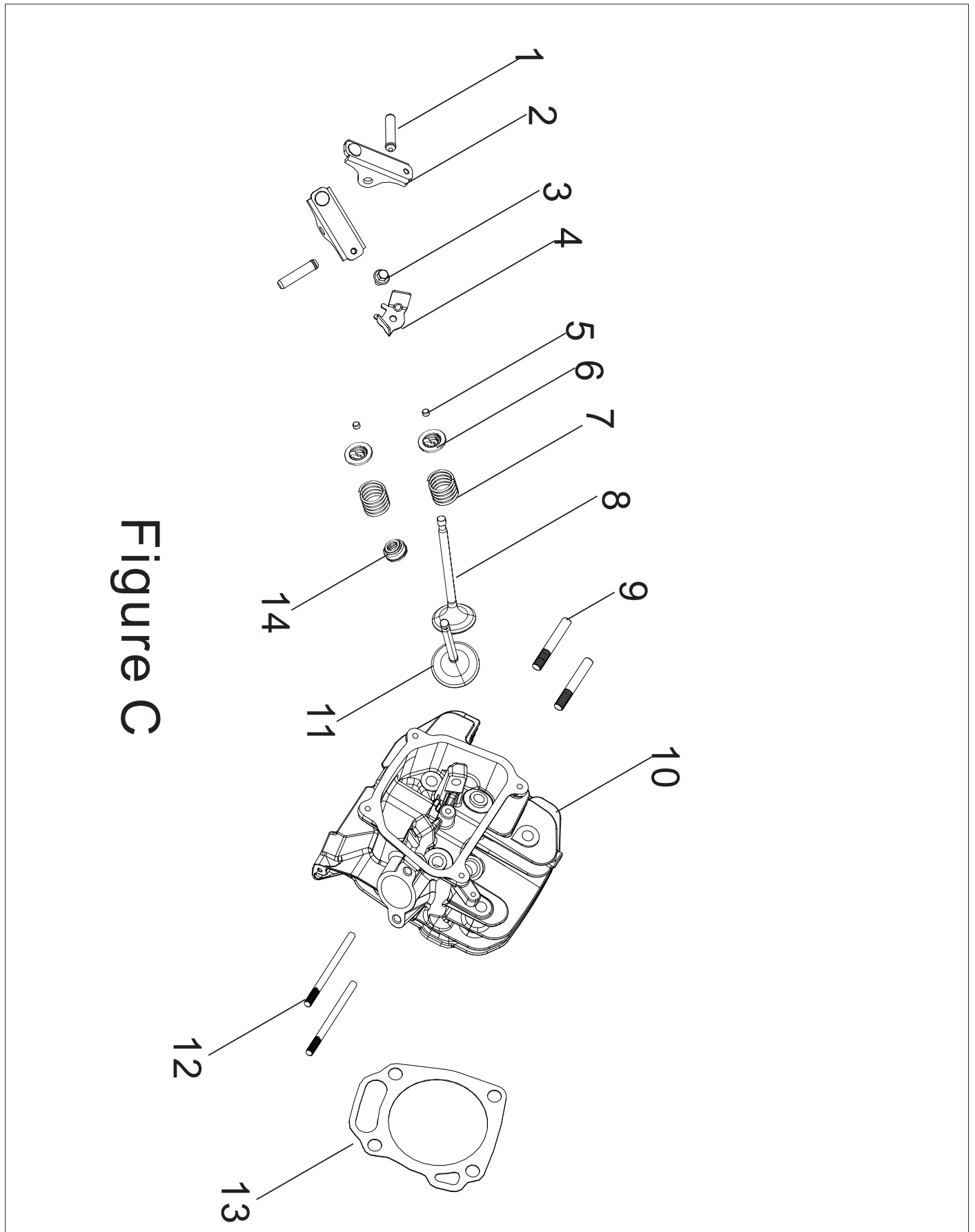

Figure C

**Figure C Part List**

#	Part Number	Description	Qty.
1	14318-000006	Valve Rocker Shaft Subassembly	2
2	14310-000003	Valve Rocker Subassembly	2
3	90001-000018	Hexagon Flange Bolt, M6 x 12, White Zinc	1
4	12419-000002	Pin Plate, Cylinder Head Cover	1
5	12104-000001	Valve Adjusting Cap, Ø5.6 x Ø8.5 x 5.2	2
6	12107-000001	Valve Spring Retainer, Exhaust valve	2
7	12103-000009	Valve Spring, Ø19.1 x Ø2.5 x 38	2
8	12121-000003	Exhaust Valve	1
9	90204-000019	Stud, M8 x 47, Black Zinc	2
10	12140-000028	Cylinder Head	1
11	12111-000002	Intake Valve	1
12	90204-000020	Stud, M6/M8 x 114, Black Zinc	2
13	12131-000006	Cylinder Head Gasket	1
14	12101-000005	Seal Guide	1

Figure D Parts Diagram

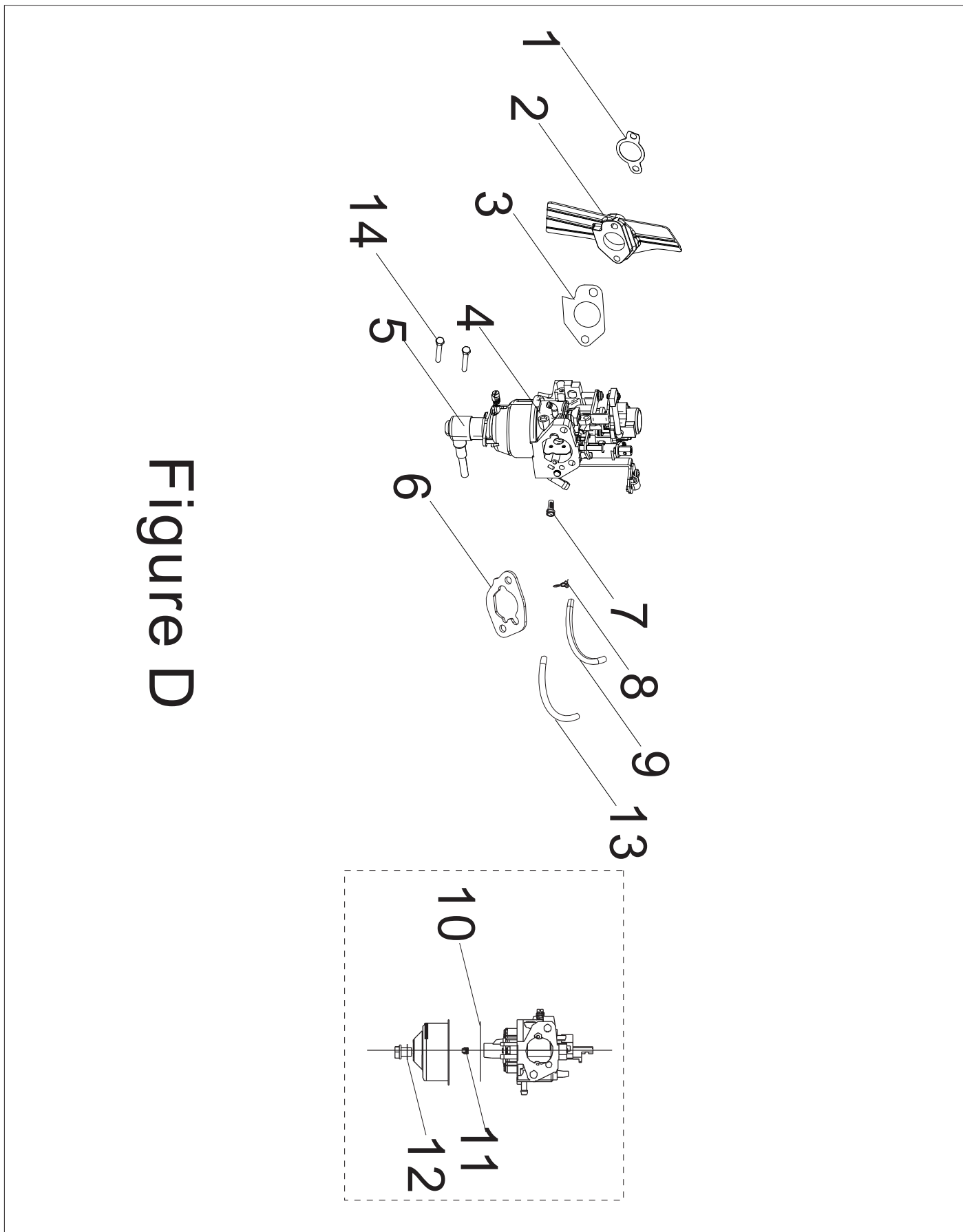

Figure D

**Figure D Part List**

#	Part Number	Description	Qty.
1	17002-000004	Gasket, Inlet	1
2	16003-000008	Carburetor Insulator Plate	1
3	16001-000003	Carburetor Gasket	1
4	16100-000023	Carburetor Assembly	1
5	16108-000005	Magnetic Valve	1
6	17001-000010	Air Cleaner Gasket	1
7	16652-000016	Fuel Filter	1
8	90685-000002	Clamp, Ø9 x Ø0.8 x 8, Army Green Zinc	1
9	90686-000008	Fuel Tube, Ø4.5 x Ø8.5 x 260	1
10	16112-000011	Seal Ring, Float	1
11	16161-000060	Main Jet (H128×0.52), Standard	1
	16161-000058	Main Jet (H128X0.55), Altitude 3000-6000 Feet	/
	16161-000007	Main Jet (H128X0.58), Altitude 6000-8000 Feet	/
12	90681-000008	Seal Ring	1
13	30431-000010	Rubber Sleeve, Ø10×Ø11×180	1
14	90102-000001	Hexagon Socket Bolt, M5 x 12, White Zinc	2

Figure E Parts Diagram

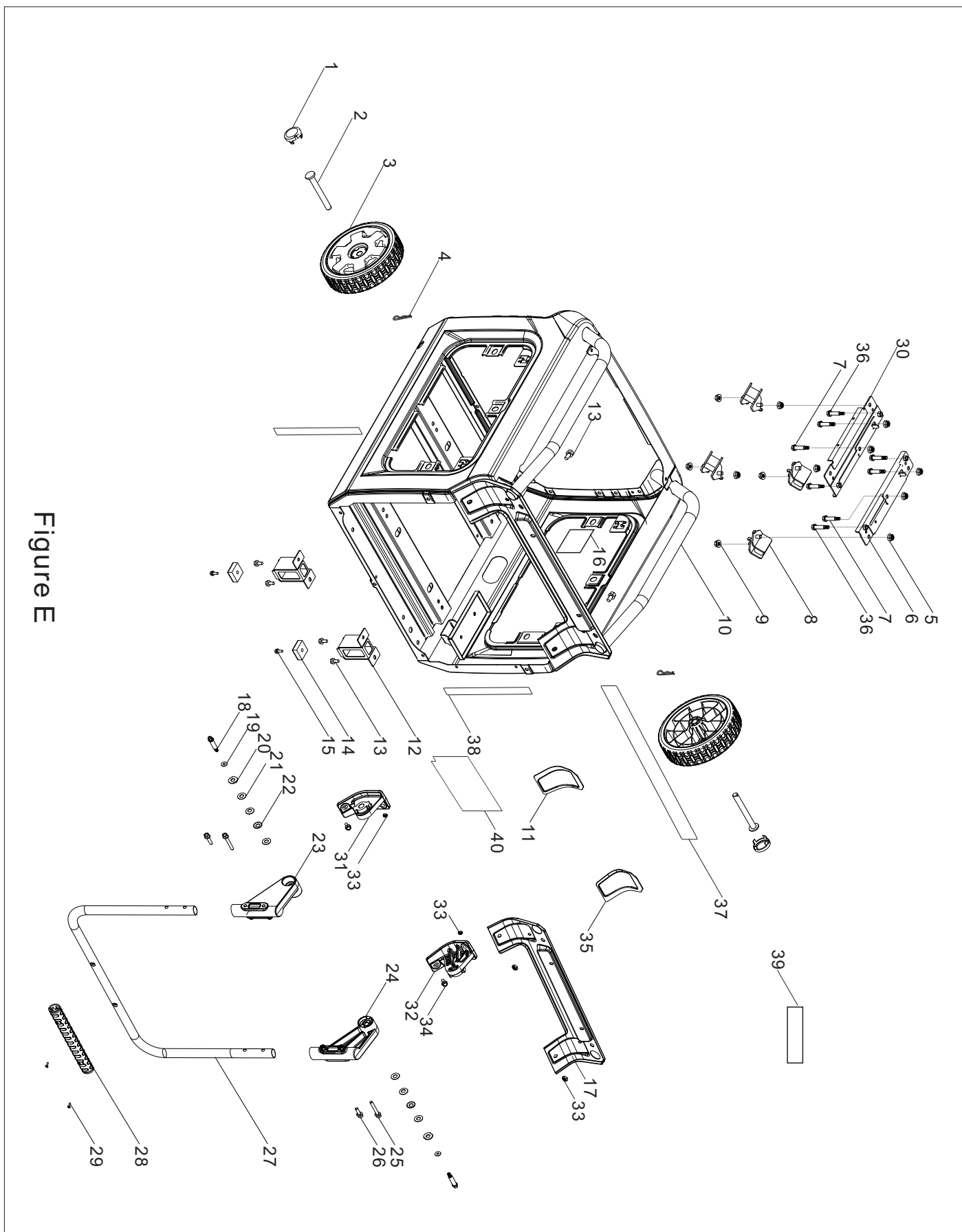

Figure E

## Figure E Part List

#	Part Number	Description	Qty.
1	44001-000003	Cover, Hub Decorated	2
2	42002-000003	Axle, Black Zinc	2
3	44110-000008	Wheel, 9.5in, Yellow	2
4	90501-000004	R-Clip, Black Zinc	2
5	90306-000001	Hexagon Flange Nut, M10, White Zinc	8
6	51002-000016	Engine base plate	1
7	90002-000002	Hexagon Flange Bolt, M10 x 40, White Zinc	4
8	51005-000009	Vibration Mount 1, Frame	4
9	90305-000010	Hexagon Flange Nut, M8, White Zinc	4
10	51100-000045	Frame Assembly	1
11	51198-000003	Sealing Strip, Right	1
12	51016-000005	Bracket, Support Leg	2
13	90001-000041	Hexagon Flange Bolt, M8 x 16, Black Zinc	6
14	51014-000005	Support Leg	2
15	90001-000023	Hexagon Flange Bolt, M6 x 16, Black Zinc	2
16	51198-000009	Sealing Strip, 100 x 100 x 2	1
17	51150-000001	Guard Plate Assembly	1
18	71116-000001	Connecting Bolt, M8 x 1.25 x 11.5, Black Zinc	2
19	90412-000001	Flat Washer, Ø12.2 x 27 x 2	2
20	42017-000001	Locking Washer, White Zinc	2
21	90412-000002	Flat Washer, Ø13 x 25 x 1, White Zinc	4
22	90419-000002	Washer, Butterfly, Ø12.2 x 25 x 1 x 2, Black Zinc	4

#	Part Number	Description	Qty.
23	54122-000003	Left Seat, Handle Tube Connecting	1
24	54122-000004	Right Seat, Handle Tube Connecting	1
25	90001-000052	Hexagon Flange Bolt, M8 x 45, Black Zinc	2
26	90001-000038	Hexagon Flange Bolt, M8 x 10, Black Zinc	2
27	54110-000011	Handle, Ø25 x 1.2	1
28	54101-000006	Handle Sheath, PMS 109C	1
29	90103-000007	Screw, M4 x 16, Black Zinc	2
30	51002-000015	Engine base plate 1	1
31	54113-000002	Left Seat, Handle Tube Connecting	1
32	54113-000003	Right Seat, Handle Tube Connecting	1
33	90305-000011	Hexagon Flange Nut, M8, Black Zinc	4
34	90007-000021	Hexagon Flange Bolt, M8 x 20, Black Zinc	2
35	51198-000002	Sealing Strip, Left	1
36	71116-000002	Connecting Bolt, M8 x 1.25 x 11.5, Orange	4
37	51198-000001	Sealing Strip, 420x15x2	1
38	51198-000004	Sealing Strip, 330x10x2	2
39	51198-000010	Sealing Strip, 70x10x2	1
40	51198-000005	Sealing Strip, 153x68x2	1

Figure F Parts Diagram

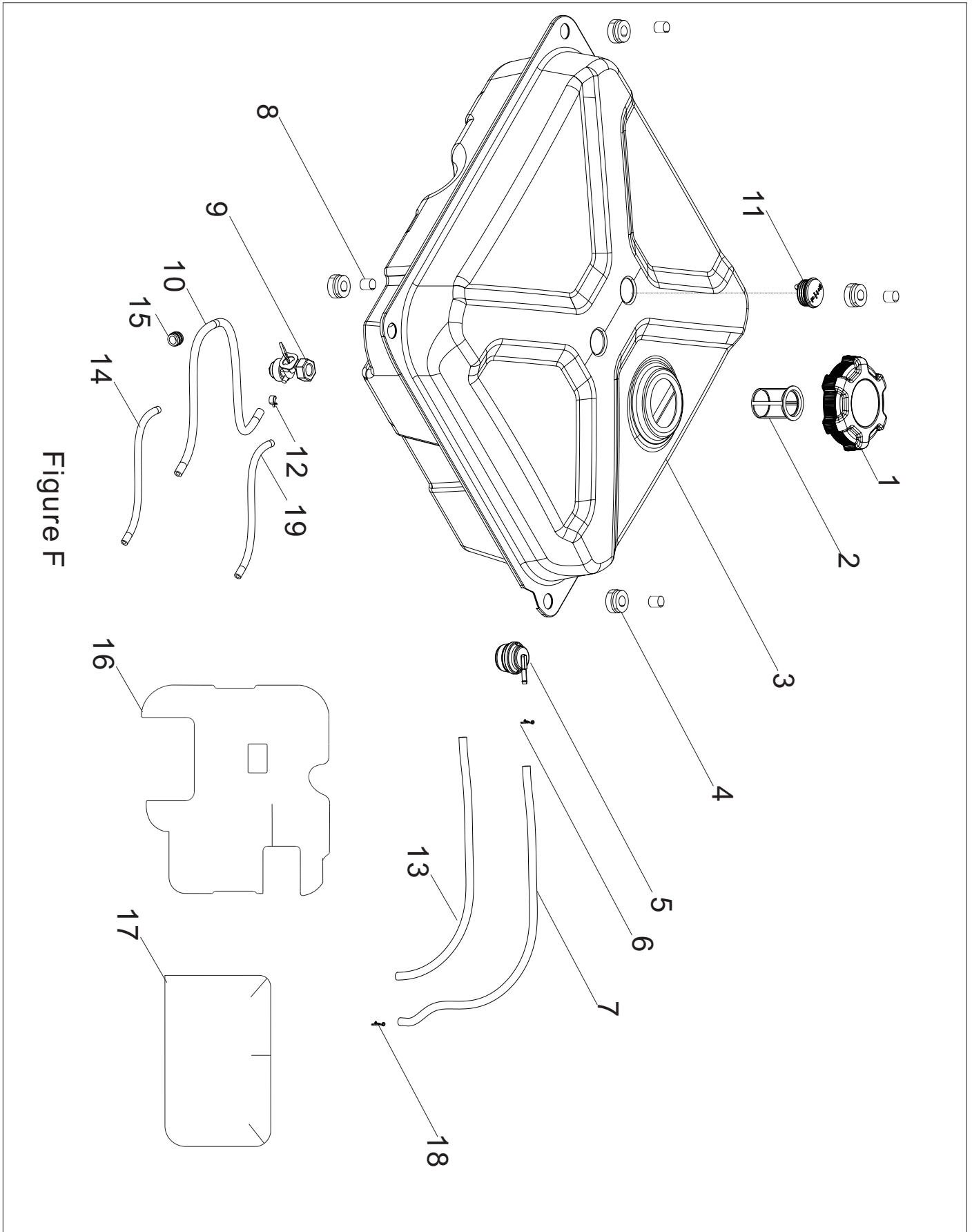

Figure F



**Figure F Part List**

#	Part Number	Description	Qty.
1	16730-000010	Fuel Tank Cap	1
2	16652-000009	Fuel Filter	1
3	16620-000008	Fuel Tank	1
4	16601-000001	Rubber Sleeve, Vibration Mount, Fuel Tank	4
5	15150-000003	One Way Valve	1
6	90740-000005	Clamp, Ø9, White Zinc	1
7	16805-000017	Connection Tube, Air Cleaner	1
8	90683-000001	Bushing, White Zinc	4
9	16750-000009	Fuel Valve Assembly	1
10	90686-000011	Fuel Tube, Ø4.5 × Ø8.5 × 340	1
11	37200-000012	Fuel Gauge	1
12	90685-000013	Clamp, Ø8.5 x 8 x 0.6	1
13	30431-000007	Rubber Sleeve, Ø9.5 x Ø11 x 300	1
14	30431-000013	Rubber Sleeve, Ø9.5 x Ø11 x 150	1
15	30431-000026	Rubber Sleeve, Ø8.5 x Ø17 x 17	1
16	82153-000006	Heat Insulation Cotton 1	1
17	82153-000007	Heat Insulation Cotton 2	1
18	90685-000002	Clamp, Ø9 x 0.8 x 8	1
19	30431-000025	Rubber Sleeve, Ø9.5 x Ø11 x 125	1

Figure G Parts Diagram

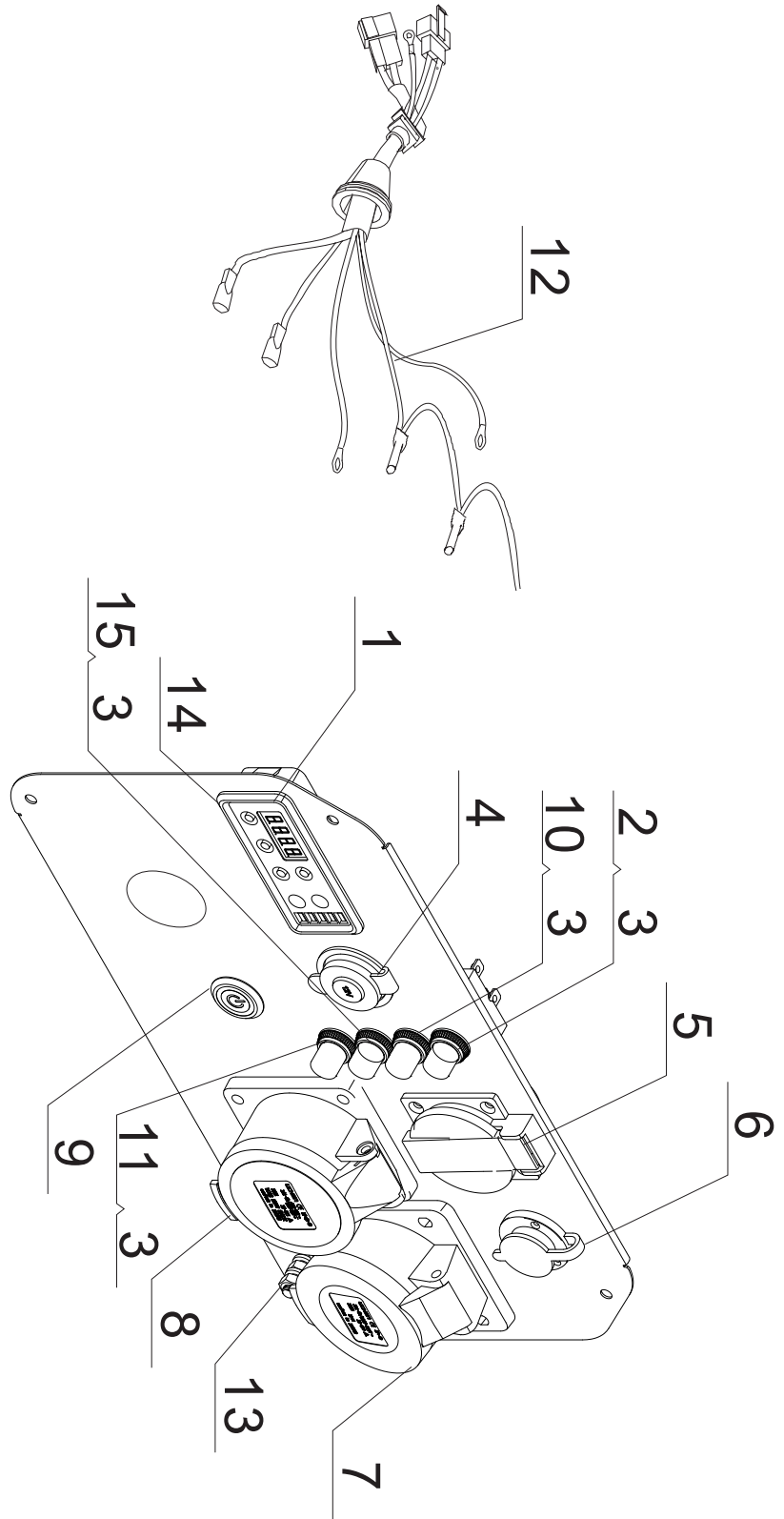
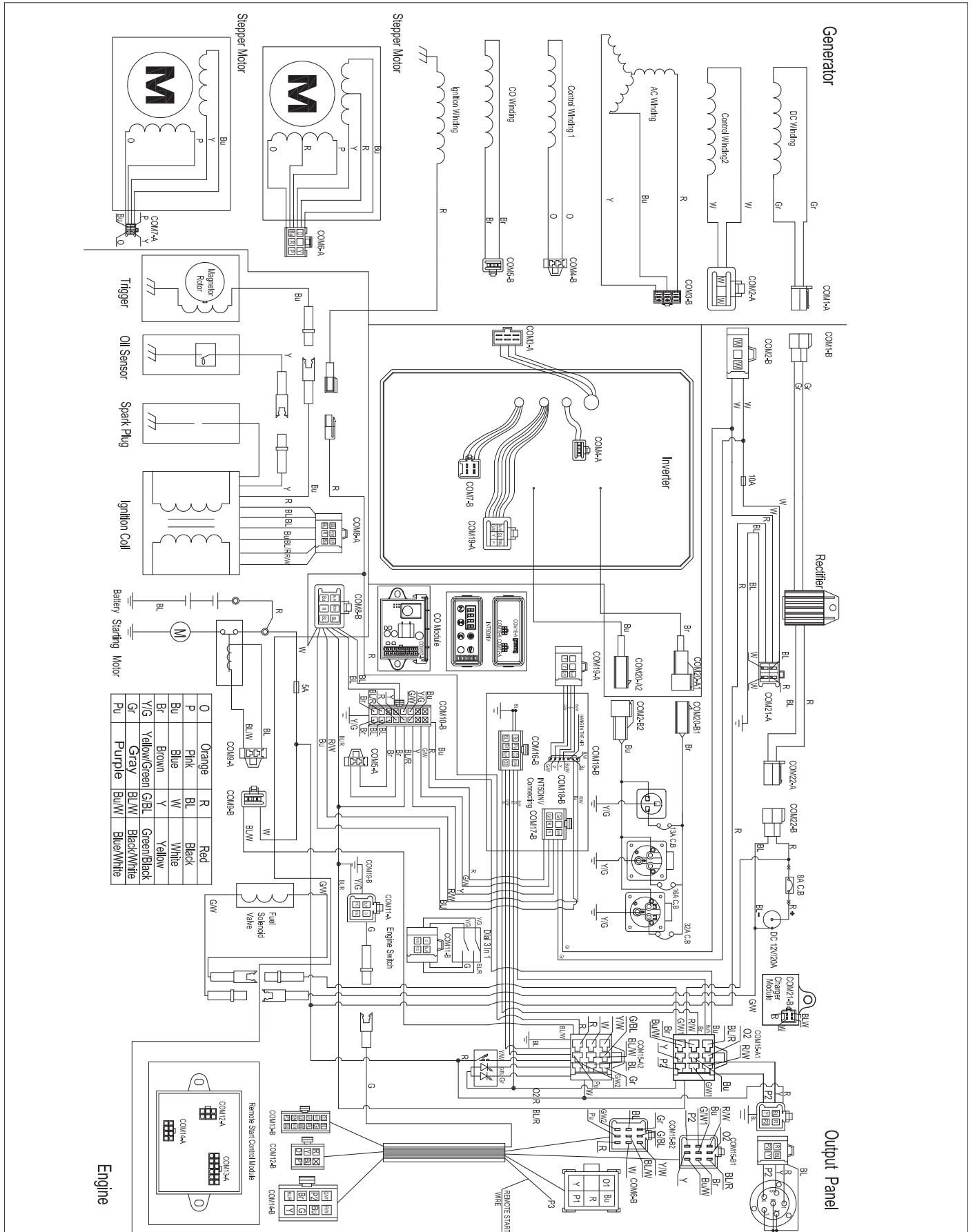

Figure G

**Figure G Part List**

#	Part Number	Description	Qty.
1	35650-000039	Control Panel	1
2	31234-000002	Circuit Breaker, Push Botton, 125/250V 8A	1
3	35654-000005	Receptacle Cover,Circuit Breaker	4
4	35619-000001	Automotive Receptacle, 12V DC	1
5	35614-000030	Receptacle, 13A, 250V	1
6	35614-000027	Receptacle,ATS	1
7	35614-000028	Receptacle, 32A, 250V	1
8	35614-000029	Receptacle, 16A, 250V	1
9	35160-000017	Switch Assembly, Engine	1
10	31234-000010	Circuit Breaker, Push Botton, 125/250V 13A	1
11	31234-000012	Circuit Breaker, Push Botton, 125/250V 32A	1
12	35660-000047	Cable, Control Panel	1
13	35629-000001	Ground Termina Assembly	1
14	35632-000018	Intelligauge, INT5DINV	1
15	31234-000011	Circuit Breaker, Push Botton, 125/250V 16A	1

Wiring Diagram



## TROUBLESHOOTING

Problem	Cause	Solution	
Engine will not start.	No fuel.	Add fuel.	
	Faulty spark plug.	Clean and adjust spark plug or replace.	
	Low oil level.		Fill crankcase to the proper level.
			Place generator on a flat, level surface.
	Spark plug wire loose.	Attach wire to spark plug.	
	EZ Start dial OFF.	Turn EZ Start dial ON.	
	Old fuel or water in fuel.	Drain fuel and replace with fresh fuel.	
	Flooded with fuel.	Let unit stand for 10 mins.	
CO Shield® module has been removed or tampered with.	Re-install module or contact technical support.		
Engine starts but runs roughly.	Choke in the wrong position.	Move EZ Start Dial to the RUN position.	
	Dirty air filter.	Clean or replace air filter.	
	Dirty fuel valve.	Clean the fuel valve.	
	Clogged spark arrestor.	Clean spark arrestor.	
Engine shuts down during operation.	Out of fuel.	Fill fuel tank.	
	Low oil level.	Fill crankcase to the proper level. Place generator on a flat, level surface.	
	If equipped, when CO Shield® shutoffs occur due to accumulating carbon monoxide (CO) and if the red LED light blinks on the panel.		Move generator to an open, outdoor area. Point exhaust away from people and buildings. Move to fresh air and get medical help if sick, dizzy, or weak.
			Make sure there are no objects creating obstructions within 5 feet of the generator. Obstructions in the vicinity of the generator may trap carbon monoxide emissions near the generator and cause the engine to shutoff. If the generator's exhaust is facing into the wind, the exhaust may be blown back into the generator's operating area, creating an accumulation of CO emissions and triggering an engine shutoff. To avoid an engine shutoff, turn the generator 45° in either direction to allow the exhaust emissions to blow away from the generator. If engine shutoff events continue, readjust and align the exhaust with the wind direction to blow away from the generator.
	If equipped, when CO Shield® shutoffs occur due to system fault and if the yellow LED light blinks on the panel.	Start by confirming yellow LED light blinks when/if generator shuts off. If CO Shield continues to sense the fault and shuts off, contact technical support.	
Clogged spark arrestor.	Clean spark arrestor.		

Problem	Cause	Solution
Engine starts and shuts off right away.	If equipped, when CO Shield® shutoffs occur due to accumulating carbon monoxide (CO) and if the red LED light blinks on the panel.	<p>Move generator to an open, outdoor area. Point exhaust away from people and buildings. Move to fresh air and get medical help if sick, dizzy, or weak.</p> <p>Make sure there are no objects creating obstructions within 5 feet of the generator. Obstructions in the vicinity of the generator may trap carbon monoxide emissions near the generator and cause the engine to shutoff.</p> <p>If the generator's exhaust is facing into the wind, the exhaust may be blown back into the generator's operating area, creating an accumulation of CO emissions and triggering an engine shutoff. To avoid an engine shutoff, turn the generator 45° in either direction to allow the exhaust emissions to blow away from the generator. If engine shutoff events continue, readjust and align the exhaust with the wind direction to blow away from the generator.</p>
	If equipped, when CO Shield® shutoffs occur due to system fault and if the yellow LED light blinks on the panel.	Start by confirming yellow LED light blinks when/if generator shuts off. If CO Shield continues to sense the fault and shuts off, contact technical support.
Both CO Shield® LEDs not blinking 10 times upon start up.	Starting the generator within 1 minute after being manually shutoff, not a CO shutoff event.	Wait 1 minute before trying to restart the generator. The LEDs should then blink ten (10) times.
Generator cannot supply enough power or overheating.	Generator is overloaded.	Review load and adjust. See "Connecting Electrical Loads."
	Dirty air filter.	Clean or replace air filter.
	Choke in the wrong position.	Move EZ Start Dial to the RUN position.

Problem	Cause	Solution
Engine is running but no AC output.	Poor cord connection.	Check all connections.
	Circuit breaker is open.	Reset circuit breaker. Check all circuit breakers.
	Loose wiring.	Inspect and tighten wiring connections.
	AC Overload: Button illuminated red	Reduce AC load and press Overload Reset Button until illuminated green.
	Other.	Contact the help line.
Engine hunts or falters.	Engine governor defective.	Contact the help line.
	Dirty fuel valve.	Clean the fuel valve.
	Carburetor is dirty and running lean.	Contact the help line.
	Choke in the wrong position.	Move EZ Start Dial to the RUN position.
Repeated circuit breaker tripping.	Overload.	Review load and adjust. See "Connecting Electrical Loads."
	Faulty power cords or device.	Check for damaged, bare or frayed wires. Replace defective device.
	Circuit breaker still too hot.	Let unit sit for 5 mins.



## WARRANTY\*

CHAMPION POWER EQUIPMENT  
3 YEAR LIMITED WARRANTY

### Warranty Qualifications

To register your product for warranty and FREE lifetime call center technical support please visit:

[www.championpowerequipment.co.uk](http://www.championpowerequipment.co.uk)

To complete registration you will need to include a copy of the purchase receipt as proof of original purchase. Proof of purchase is required for warranty service. Please register within ten (10) days from date of purchase.

### Repair/Replacement Warranty

CPE warrants to the original purchaser that the mechanical and electrical components will be free of defects in material and workmanship for a period of three (3) years for domestic usage and One (1) Year for commercial and industrial use. Transportation charges on product submitted for repair or replacement under this warranty are the sole responsibility of the purchaser.

This warranty only applies to the original purchaser and is not transferable. For full T&C's please visit [www.championpowerequipment.co.uk](http://www.championpowerequipment.co.uk)

### Do Not Return The Unit To The Place Of Purchase

Contact CPE's Technical Service and CPE will troubleshoot any issue via phone or e-mail. If the problem is not corrected by this method, CPE will, at its option, authorize evaluation, repair or replacement of the defective part or component at a CPE Service Center. CPE will provide you with a case number for warranty service. Please keep it for future reference. Repairs or replacements without prior authorization, or at an unauthorized repair facility, will not be covered by this warranty.

### Warranty Exclusions

This warranty does not cover the following repairs and equipment:

#### Normal Wear

Products with mechanical and electrical components need periodic parts and service to perform well. This warranty does not cover repair when normal use has exhausted the life of a part or the equipment as a whole.

#### Installation, Use and Maintenance

This warranty will not apply to parts and/or labor if the product is deemed to have been misused, neglected, involved in an accident, abused, loaded beyond the product's limits, modified, installed improperly or connected incorrectly to any electrical component. Normal maintenance is not covered by this warranty and is not required to be performed at a facility or by a person authorized by CPE.

### Other Exclusions

This warranty excludes:

- Cosmetic defects such as paint, decals, etc.
- Wear items such as filter elements, o-rings, etc, piston rings.
- Accessory parts such as starting batteries, and storage covers.
- Failures due to acts of God and other force majeure events beyond the manufacturer's control.
- Problems caused by parts that are not original Champion Power Equipment parts.

When applicable, this warranty does not apply to products used for prime power in place of a utility or city power.

### Limits of Implied Warranty and Consequential Damage

Champion Power Equipment disclaims any obligation to cover any loss of time, use of this product, freight, or any incidental or consequential claim by anyone from using this product. THIS WARRANTY AND THE ATTACHED U.S. EPA and/or CARB EMISSION CONTROL SYSTEM WARRANTIES (WHEN APPLICABLE) ARE IN LIEU OF ALL OTHER WARRANTIES, EXPRESS OR IMPLIED, INCLUDING WARRANTIES OF MERCHANTABILITY OR FITNESS FOR A PARTICULAR PURPOSE.

A unit provided as an exchange will be subject to the warranty of the original unit. The length of the warranty governing the exchanged unit will remain calculated by reference to the purchase date of the original unit.

This warranty gives you certain legal rights which may change from state to state or province to province. Your state or province may also have other rights you may be entitled to that are not listed within this warranty.

### Contact Information

Winch Solutions Ltd

Unit 17-18 Bradley Trading Estate

Standish WN6 0XQ / UK

[www.championpowerequipment.co.uk](http://www.championpowerequipment.co.uk)

[support@cpeurope.co.uk](mailto:support@cpeurope.co.uk)



We: CHAMPION POWER EQUIPMENT, INC.  
12039 SMITH AVENUE, SANTA FE SPRINGS,  
CA 90670, USA

Hereby declare that the following Appliance complies with the appropriate basic safety and health requirements of the UKCA Directives (see item 3 & 4) based on its design and type, as brought into circulation by us.

This declaration relates exclusively to the machinery in the state in which it was placed on the market, and excludes components which are added and/or operations carried out subsequently by the final user.

Designation / Function: Low Power generating sets

1. Type: 97001i-P-UK
2. Serial number: xxxxxxxxxxxxxx(on Dataplate Label and Package)
3. Used harmonized standards:
  - ISO 8528-13:2016
4. Applicable UKCA Directives:
  - Supply of Machinery (Safety) Regulations 2008
  - Directive (EU) 2016/1628
  - Noise Emission in the Environment Regulations S.I. 2001/1701
  - Electrical Equipment (Safety) Regulations 2016
  - Electromagnetic Compatibility Regulations 2016

Guaranteed sound power level:  
-96 dB(A) for 97001i-P-UK

5. Responsible for documentation: CHAMPION POWER EQUIPMENT, INC.  
Address: 12039 SMITH AVENUE, SANTA FE SPRINGS, CA 90670, USA

6. Person responsible for compiling the technical files established within the EUName, Surname: Winch Solutions LTD  
Address: Unit 17-18 Bradley Trading Estate, Bradley lane, Standish, Greater Manchester, WN6 0XQ, UK

7. Date/Place/Authorized Signature: August 20th 2023/Hangzhou/LI JIE

For and on behalf of  
Champion Power Equipment, Inc.  
  
-----  
Authorized Signature

8. Title of Signatory: General Manager

Note:

The person importing the products becomes responsible for ensuring that they comply with the directives which apply to them. At the very last, it is recommended that the importer obtain a copy of the original Declaration of conformity from manufacturer.

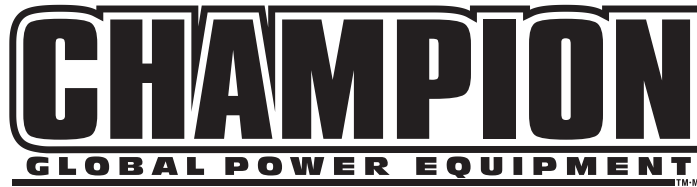

## Champion Power Equipment Europe

**For warranty and repair enquiries, please  
contact the retailer where you purchased  
your Champion Product.**

### **United Kingdom:**

BPE Holdings  
Unit 17-18  
Bradley Hall Trading Estate  
Bradley Lane, Standish  
Wigan, WN6 0XQ, UK

### **Germany:**

BPE Solutions Deutschland GmbH  
Altrottstraße 31  
D-69190 Walldorf  
Germany

### **France:**

BPE Solutions France SAS  
3 Boulevard de Belfort  
59000 Lille  
France

### **Sweden:**

BPE Nordic AB  
Valnäsgatan 2  
44252 Ytterby  
Sweden