

Wiring Diagram

THIS CIRCUIT DIAGRAM IS ONLY FOR REFERENCE, IF ANY CHANGE, THERE WILL BE WITHOUT NOTICE.

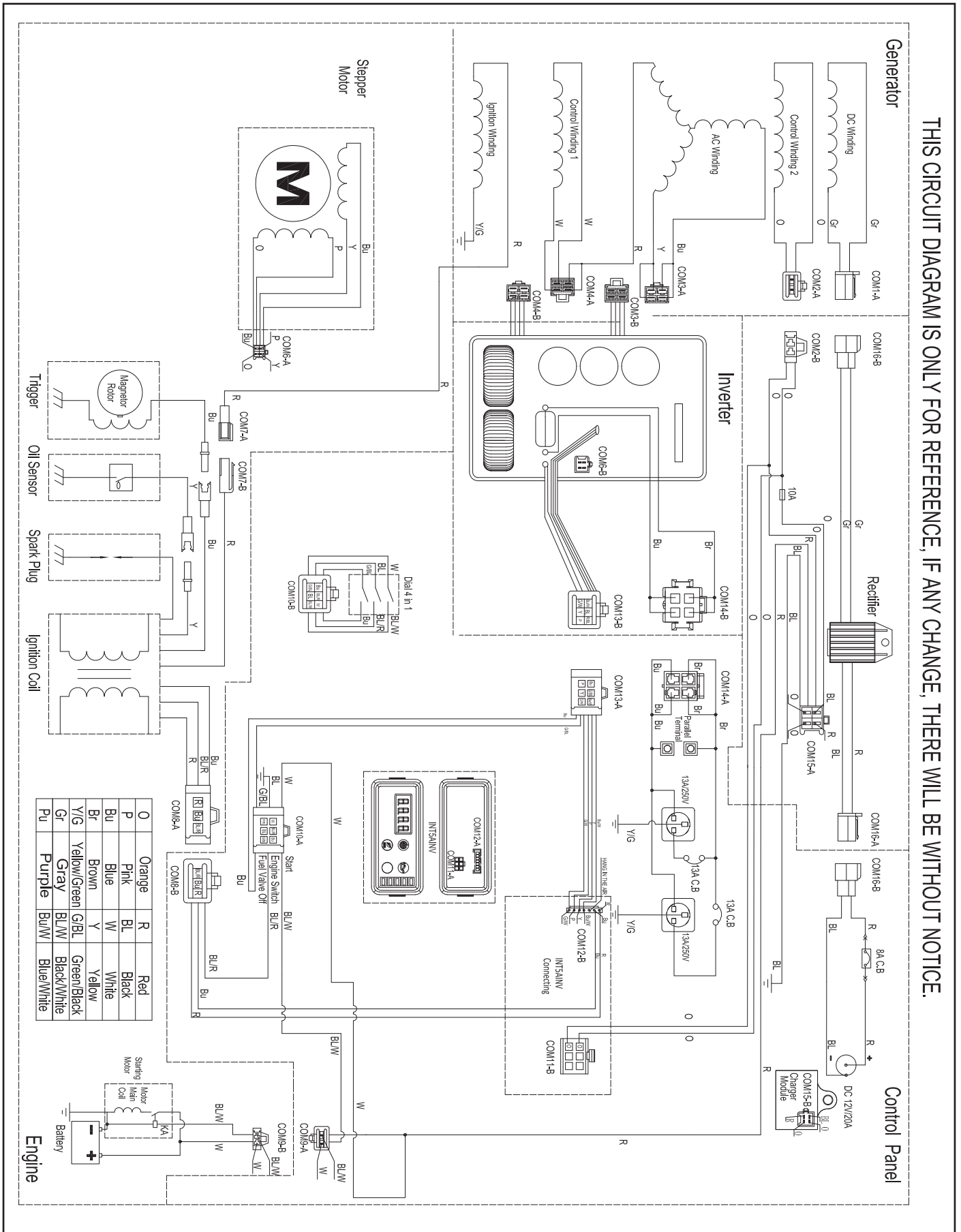

Parts Diagram Figure A

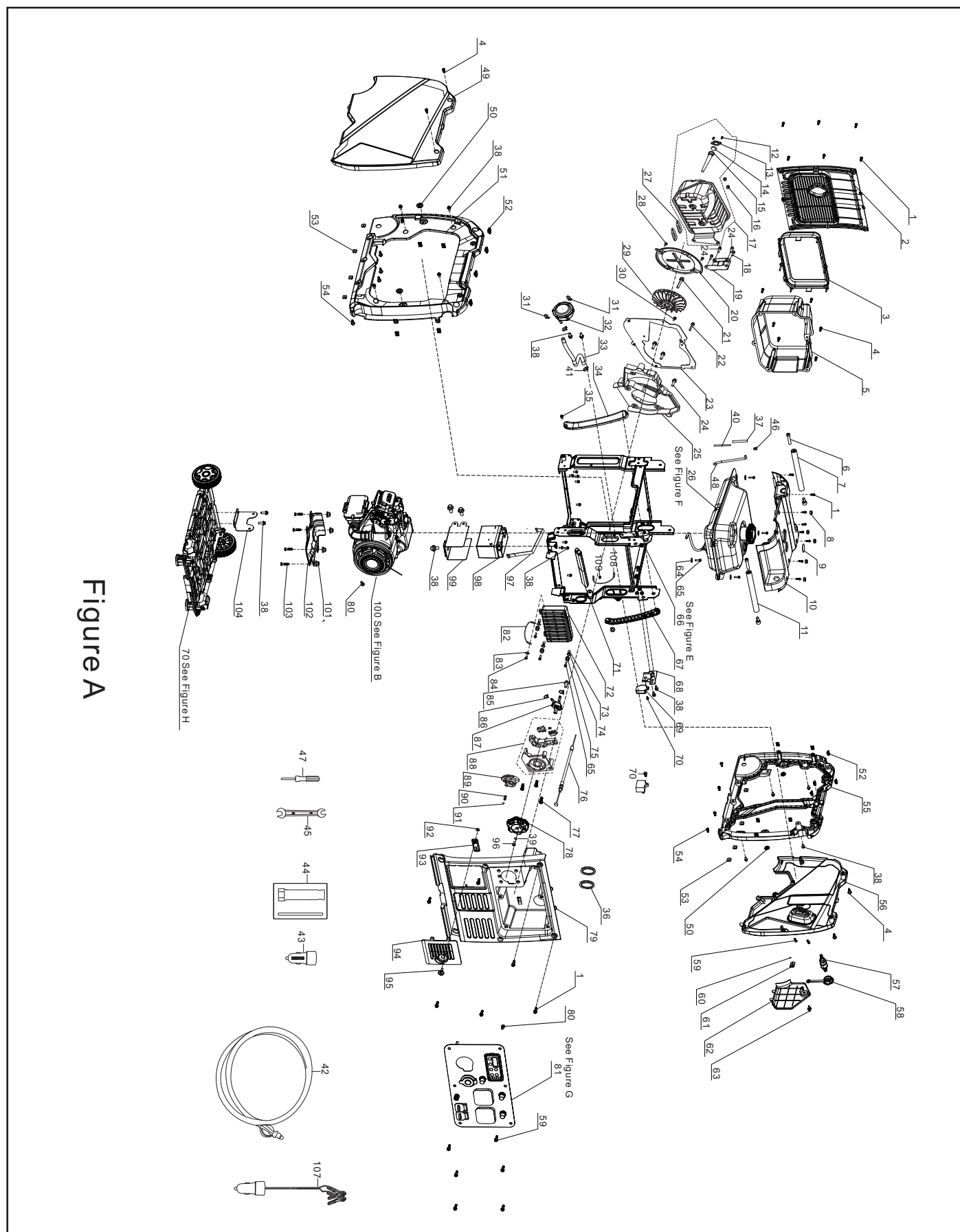

Figure A

## Parts List

#	Part Number	Description	Qty.
1	90208-YB00410-00A0	Hexagon Step Bolt, M5 x 16, 6.5mm, Black Zinc	20
2	18002HYBW0110-Q2A1	Louver, Muffler	1
3	18018-Y2P0120-00A1	Insulator Glue Cushion, Muffler	1
4	90208-YB00210-00A0	Hexagonal Step Bolt, M5 x 12, Black Zinc	10
5	18130HYBW0110-Q2A1	Muffler Guard	1
6	90115-0830-03A0	Hexagon Socket Bolt, M8 x 30, Black Zinc	4
7	80153HYBW0210-H8A1	Handle 2, Ø28 x 332	1
8	90722-YBW0110-00A1	Plug 1, End	6
9	37205-Y2V0310-00A1	Oil Lever View, Fuel Gauge	1
10	94230HYBW0110-Q2A0	Cover, Upper	1
11	80153HYBW0110-H8A1	Handle 1, Ø28 x 273	1
16	90303-0800-31A0	Hexagon Nut, M8, White Zinc	2
17	18100-YBW0111-00A0	Muffler Assembly	1
12	18012-Z800310-0000	Bolt, Spark Arrestor	2
13	18213-Z800310-0000	Cover Plate, Spark Arrestor	1
14	18218-Z800210-0000	Muffling Block	1
15	18250-Z800210-0000	Spark Arrestor	1
18	90007-0612-A1A0	Hexagon Flange Bolt, M6 x 12, White Zinc	2
19	18030HYBW0110-H7A0	Muffler Bracket	1
20	18020-YBW0110-00A0	Plate, Muffler Insulator	1
21	90001-0820-01A0	Hexagon Flange Bolt, M8 x 20, White Zinc	1
22	90007-0635-A1A0	Hexagon Flange Bolt, M6 x 35, White Zinc	1
23	18299HYBW0121-00A0	Bracket, Muffler Guard	1
24	90001-0816-01A0	Hexagon Flange Bolt, M8 x 16, White Zinc	5
25	28110HYBW0111-Q2A0	Shroud	1
26	96003-ZSS2210-0000	Fuel Tank Assembly - See Figure F	1
27	18001-Z950110-00A0	Exhaust Outlet Gasket	2
28	90134-YB00110-00A0	Bolt, Cross Hexagon Pan Head, M5 x 12	2
29	19352HYBW0110-Q2A0	Cooling Fan	1
30	90124-Y9T0310-00A0	Tapping Screw, PT4x13	1
31	90748-0812-00A0	Clamp	2

#	Part Number	Description	Qty.
32	77100-Z3R0311-00A0	Regulator, Auxiliary	1
33	90729-YMQ0110-00A0	Vent Pipe	1
34	54912HYBW0111-Q2A1	Rotating Arm, Left	1
35	90001-0612-03A0	Hexagon Flange Bolt, M6 x 16, Black Zinc	2
36	30431-Y2V0310-00A1	Rubber Sleeve, Ø30 x Ø40 x 9.8	2
37	30431-YBW0210-00A1	Rubber Sleeve, Ø10 x Ø11 x 180	1
38	90001-0612-01A0	Hexagon Flange Bolt, M6 x 12, White Zinc	26
39	90408-0400-E1A0		1
40	30431-Y020110-00A1	Rubber Sleeve, Fuel Pipe	1
41	90748-1222-00A0	Clamp	2
42	77300HYMQ0110-00A0	LPG Hose With Regulator	1
43	35613-YBE0110-0000	12VDC USB Adapter	1
44	93130-Z010410-0100	Spark Plug Socket	1
45	93107-Y920210-01A0	Wrench, 8 x 10	1
46	90685-D105-0EA0	Clamp, Ø10.5 x 8 x 0.8	2
47	93120-Y020310-00A0	Screwdriver	1
48	16804-YG80110-0001	Connection Pipe	1
49	80092HYMQ0110-L4A0	Cover Board, Left	1
50	16601-Y2V0210-00A1	Vibration Mount 2, Fuel Tank	4
51	80091HYBW0110-Q2A1	Shell, Left	1
52	17199-YE50210-01A0	Clip Nut, M5, White Zinc	16
53	90326-Y2V0110-00A0	Square Nut, M6, White Zinc	8
54	90208-YB00110-00A0	Hexagonal Step Bolt, M6 x 20, Black Zinc	8
55	80095HYBW0110-Q2A1	Shell, Right	1
56	80096HYMQ0110-L4A0	Cover Board, Right	1
57	16021-YJR0210-00A0	Inlet Connection	1
58	90722-YJR0110-00A0	Plug, Gas	1
59	90255-0512-53A0	Cross Recess Pan Head Screw & Washer Assembly, M5x12, Black Zinc	8
60	37073-Y2V0110-00A0	Clip, Spring	1
61	24329-Y9T0120-Q2A1	Block 1	1
62	51197HYH30110-L4A0	Side Access Panel, Service	1

#	Part Number	Description	Qty.
63	80105-YB00110-Q2A1	Knob, Side Access Panel, Service	1
64	90408-Y020310-00A0	Flat Washer, White Zinc	4
65	90001-0625-01A0	Hexagon Flange Bolt, M6 x 25, White Zinc	7
66	96003-ZSS7810-0000	Frame Assembly - See Figure E	
67	54912HYBW0211-Q2A1	Right, Rotating Arm	1
68	51124-YJR0110-0000	Mounting Bracket	1
69	30060-YB30110-00A0	Regulator	1
70	90001-0616-03A0	Hexagon Flange Bolt, M6 x 16, Black Zinc	2
71	54913-YBW0110-GUA0	Rotating Bar	1
72	30043-YMR0110-00A0	Inverter	1
73	90683-Y2P0210-00A0	Bushing	3
74	90406-0600-E1A0	Flat Washer, Ø6, White Zinc	3
75	30431-Y2P0110-00A1	Rubber Sleeve	3
76	16080-YBW0110-00A0	Choke Handle Subassembly	1
77	90129-0416-01A0	Cross Recess Countersunk Head Tapping Screw, ST4.2x16, White Zinc	3
78	35643HYH30210-Q2A1	Knob, Switch Dial, Engine	1
79	35680HYBW0110-Q2A1	Control Panel Housing	1
80	90001-0610-01A0	Hexagon Flange Bolt, M6 x 10, White Zinc	2
81	35610-YMQ0110-H2A1	Panel Assembly - See Figure G	1
82	30009-YH30110-00A0	Grounding Wire	1
83	90408-0500-E1A0	Flat Washer, Ø5, White Zinc	1
84	90005-0408-09A1	Hexagon Bolt, M4 x 8, White Zinc	1
85	90001-0614-01A0	Hexagon Flange Bolt, M6 x 14, White Zinc	1
86	90685-D080-0EA0	Clamp, Ø8 x 7 x 0.6	2
87	16750-Y2V0210-00A0	Fuel Valve Assembly	1
88	35160-YH30111-00A0	Switch, Engine	1
89	94111-Y2V0410-00A1	Cover Board	1
90	16527-Y2V0210-00A0	Spring, Stopper Adjusting	1
91	90543-0500-00A0	Ball, Steel	1
92	90341-YA50110-00A0	Nylon Nut	1
93	24329-YCF0110-Q2A1	Block 2	1

#	Part Number	Description	Qty.
94	31123HYBW0110-Q2A1	Cover, Battery	1
95	90208-Y9T0120-00A0	Hexagonal Step Bolt, M5 x 16, 6mm	1
96	90103-0416-51A0	Cross Recess Pan Head Screw, M4 x 16, White Zinc	1
97	31115-YBW0110-00A1	Clamp, Battery	1
98	31110-Y030610-00A0	Battery	1
99	31130-YBW0210-H6A0	Battery Holder	1
100	R210DNV10F0B-CMP06	Engine, 212cc - See Figure B	1
101	90305-0800-31A0	Hexagon Flange Nut, M8, White Zinc	4
102	19306-Z1D0110-00A0	Crankcase Air Deflector	1
103	90001-0840-01A1	Hexagon Flange Bolt, M8 x 40, White Zinc	4
104	17003HYBW0110-H7A1	Air Cleaner Support	1
105	96003-ZSS7710-0000	wheel kit - See Figure H	1
106	30007-Y9X0210-00A0	Charging Module	1
107	93041-YBE0110-00A0	Battery Charger Cables	1
108	30009-YE50210-00A0	Grounding Wire	1
109	90415-0600-Z3A1	Lock Washer, Toothed, Black Zinc	1

Parts Diagram Figure E

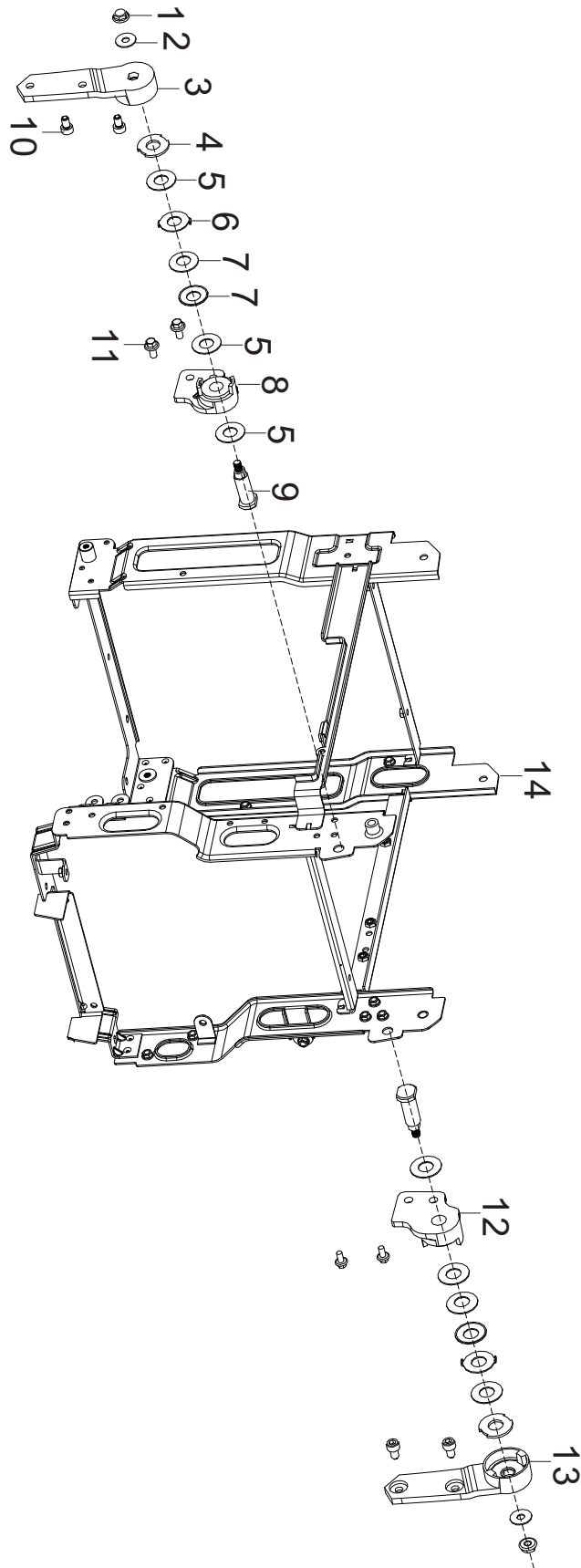

Figure E

## Parts List

#	Part Number	Description	Qty.
1	90341-Y2D0210-00A0	Nylon Nut, M6, White Zinc	2
2	90408-Y840210-00A0	Flat Washer, Ø18 x 6.5 x 1.5, White Zinc	2
3	54122-YBW0110-H7A0	Handle Tube Connecting 2, Left Seat	1
4	90412-YBW0110-Q2A0	Flat Washer, Ø12.2 x 27 x 2	2
5	90412-YBW0210-01A0	Flat Washer, Ø13 x 25 x 1, White Zinc	6
6	42017-YG80110-09A0	Lock Washer	2
7	90419-YBW0110-03A0	Washer, Butterfly, Black Zinc	4
8	54113-YBW0120-00A0	Handle Tube Connecting 1, Left Seat	1
9	26231-YBW0110-00A0	Shaft, Fixed Axis, Black Zinc	2
10	90001-0610-03A0	Hexagon Flange Bolt, M6 x 10, Black Zinc	4
11	90007-0616-A1A0	Hexagon Flange Bolt, M6 x 16, White Zinc	4
12	54113-YBW0220-00A0	Handle Tube Connecting 1, Right Seat	1
13	54122-YBW0210-H7A0	Handle Tube Connecting 2, Right Seat	1
14	51100-YJR0110-H7A0	Frame Assembly	1

Parts Diagram Figure F

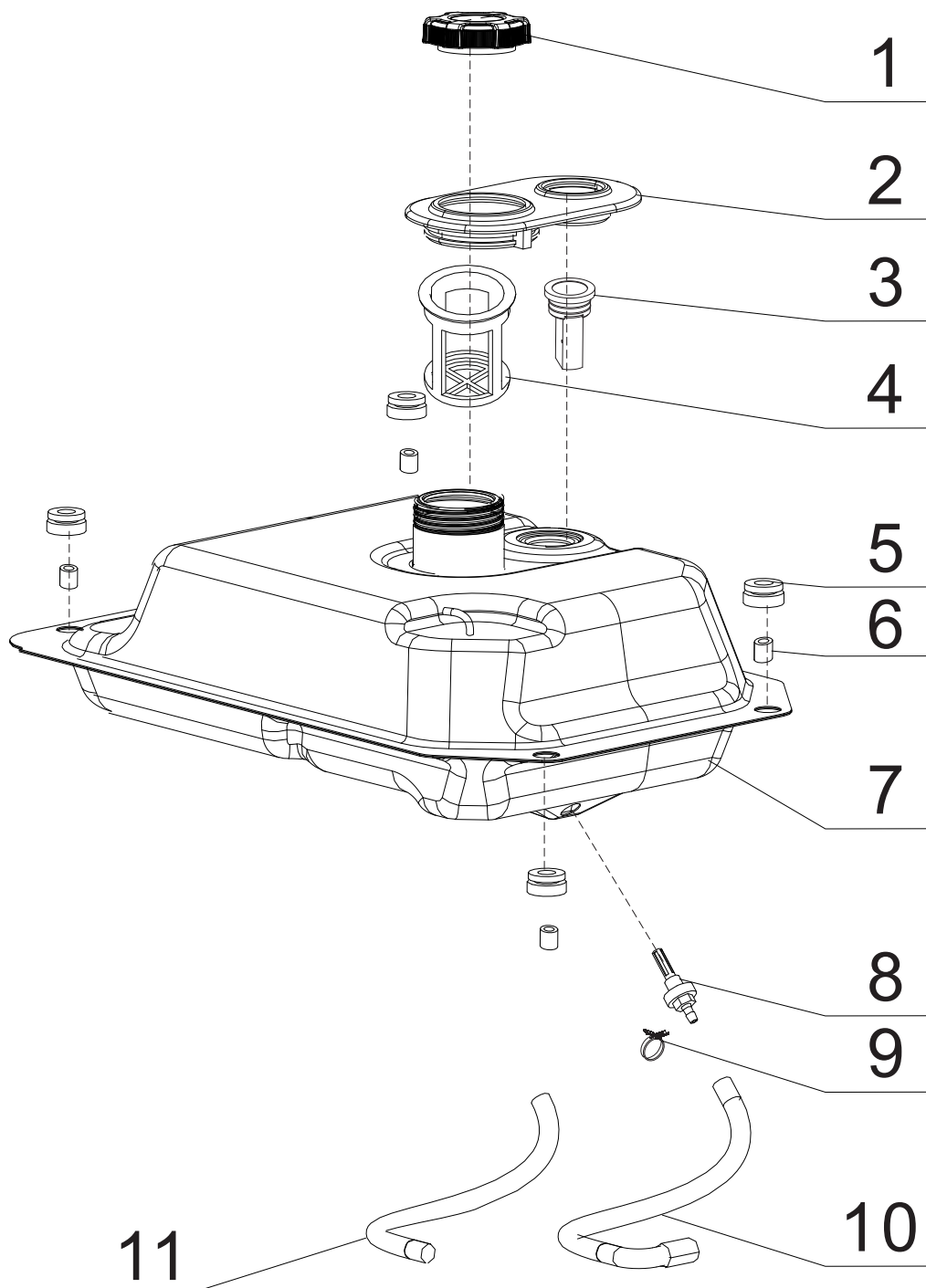

Figure F

## Parts List

#	Part Number	Description	Qty.
1	16730-YH30110-Q2A0	Fuel Tank Cap	1
2	16641-YBW0110-00A1	Rubber Sleeve, Filling Oil Hole	1
3	37200-Y5V0110-00A1	Fuel Gauge	1
4	16652-Y9T0110-00A1	Fuel Filter	1
5	16601-Y020120-00A1	Vibration Mount 1, Fuel Tank	4
6	90683-Y020110-00A0	Bushing, White Zinc	4
7	16620-YBW0111-H7A1	Fuel Tank	1
8	16680-Y2P0110-00A1	Fuel Tank Fuel Outlet Subassembly	1
9	90685-D095-0EA0	Clamp, Ø9.5 x 0.8 x 8, Army Green Zinc	1
10	90686-YBW0210-00M1	Fuel Pipe, Ø4.5 x Ø8.5 x 130	1
11	30431-Y020110-00A1	Rubber Sleeve, Fuel Pipe	1



Parts Diagram Figure G

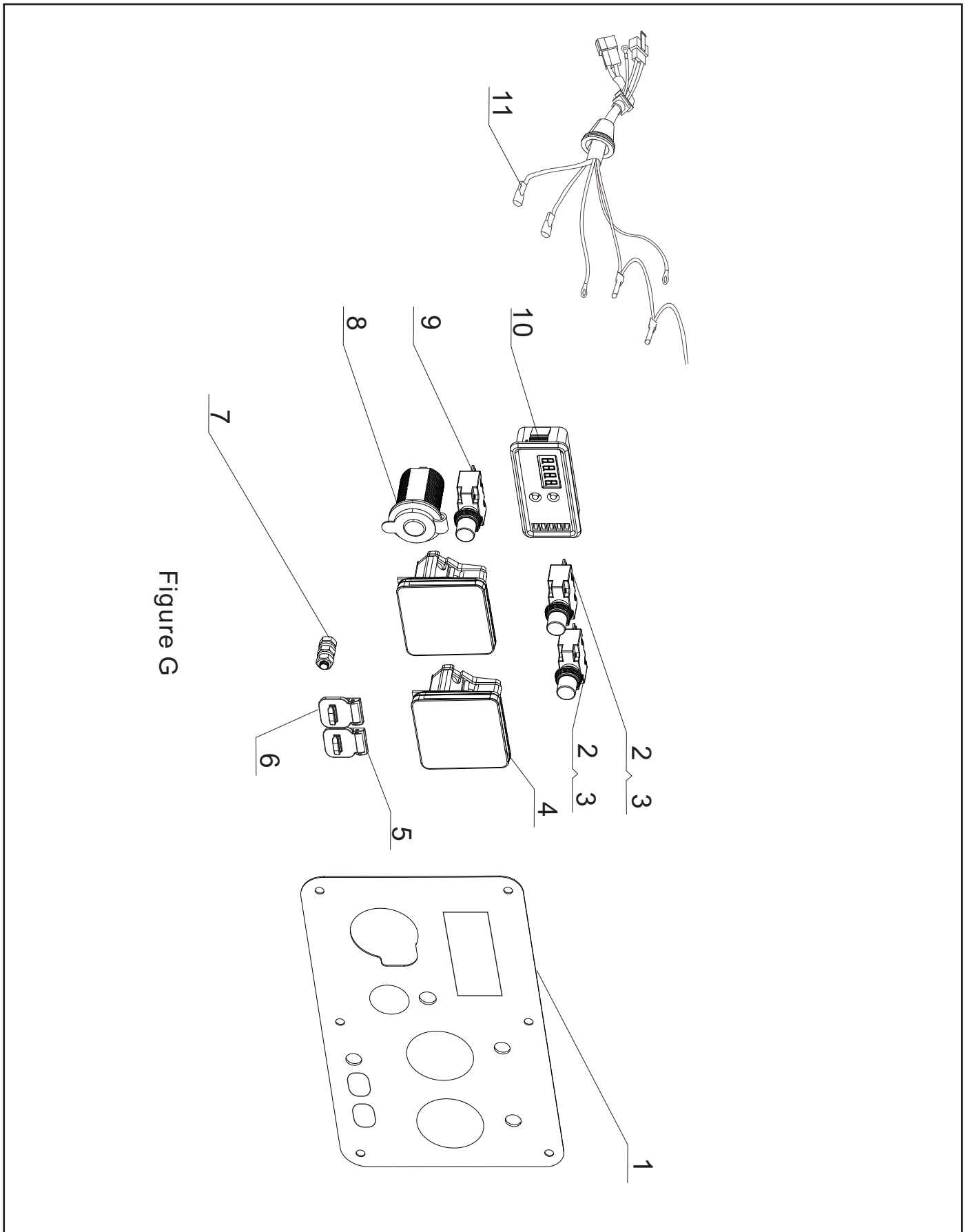

Figure G

## Parts List

#	Part Number	Description	Qty.
1	35650-YMQ0110-H2A1	Control Panel	1
2	35654-YGK0110-0000	Cover, Push Button	2
3	31234-YGK0310-0000	13 Amp Circuit Breaker, Push Button	2
4	35614-Y020410-0000	Receptacle, 30A, 125V	2
5	35614-YMQ0210-0000	Wireless Parallel, Black	1
6	35614-YMQ0110-0000	Wireless Parallel, Red	1
7	35629-Y090110-0000	Grounding Terminal	1
8	35619-Y110110-0000	Automotive Receptacle, 12V DC	1
9	31234-YBE0110-0000	8Amp Circuit Breaker, Push Button	1
10	35632-YMQ0110-0000	Multifunctional Display	1
11	35660HYMQ0110- 0000	Wire Harness, Control Panel	1

Parts Diagram Figure H

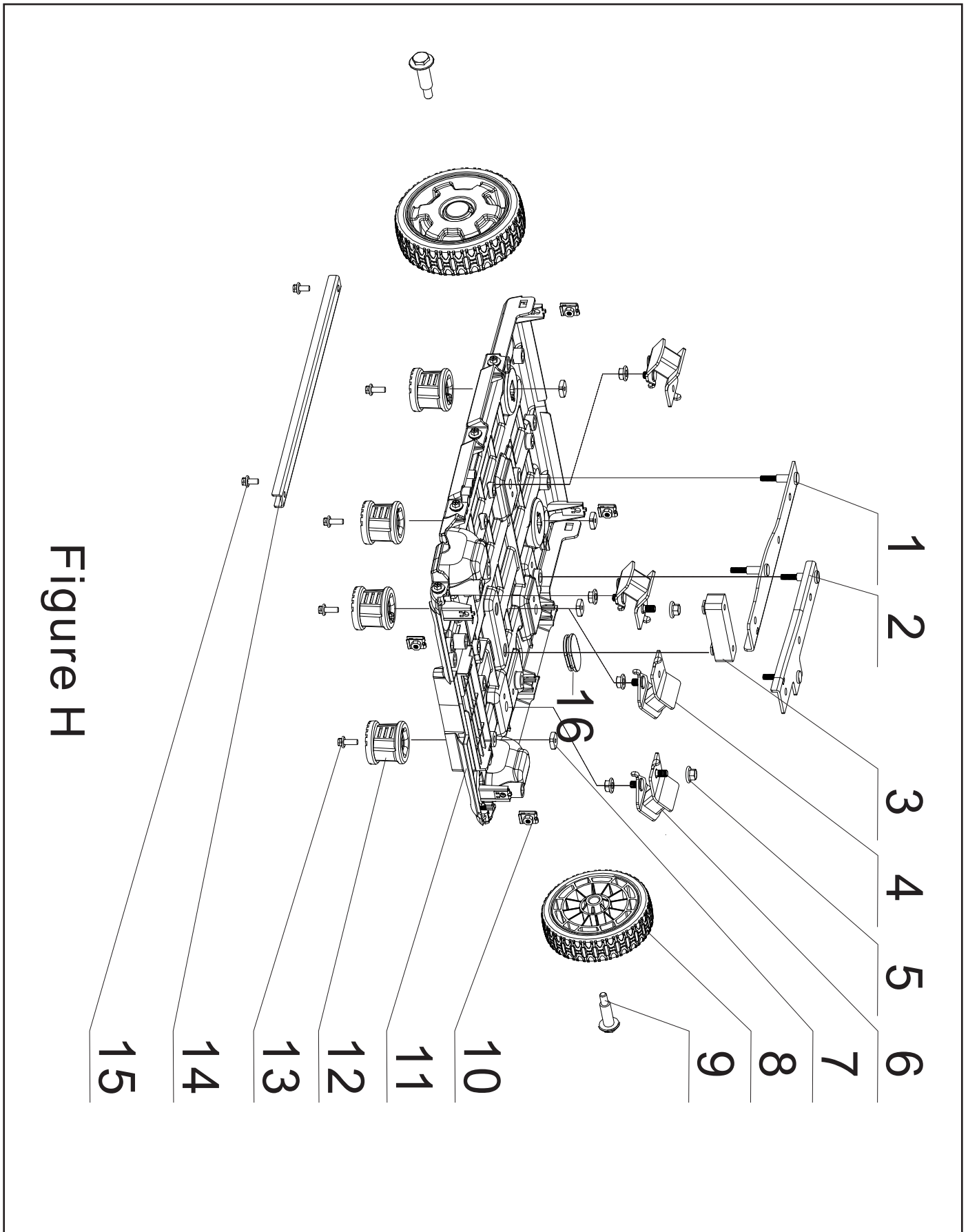

Figure H

## Parts List

#	Part Number	Description	Qty.
1	51188HYBW0110-H6A0	Left Support, Engine	1
2	51189HYBW0110-H6A0	Right Support, Engine	1
3	50035-YBW0110-00A1	Bracket, Cushion Rubber	1
4	51011HY2P0210-00A0	Vibration Mount, Right, Frame	2
5	90305-0800-31A0	Hexagon Flange Nut, M8, White Zinc	6
6	51009HY2P0110-00A0	Vibration Mount, Left, Frame	2
7	90326-Y2V0110-00A0	Square Nut, M6, White Zinc	6
8	44110HYH30110-L4A0	5in. Wheel, Yellow	2
9	42002-YH30110-03A0	Roll Pin, M8x15, Black Zinc	2
10	17199-YB00110-00A0	Clip Nut, M5, White Zinc	4
11	51143HYBW0111-Q2A1	Plate, Bottom	1
12	51014HYBW0110-00A1	Support Leg	4
13	90001-0616-01A0	Hexagon Flange Bolt, M6 x 16, White Zinc	4
14	51103-YJR0110-H7A0	Reinforcing Plate, Black Zinc	1
15	90001-0612-01A0	Hexagon Flange Bolt, M6 x 12, White Zinc	2
16	90722-Y2P0110-00A1	Plug 2, End	1

### Engine Parts Diagram Figure B

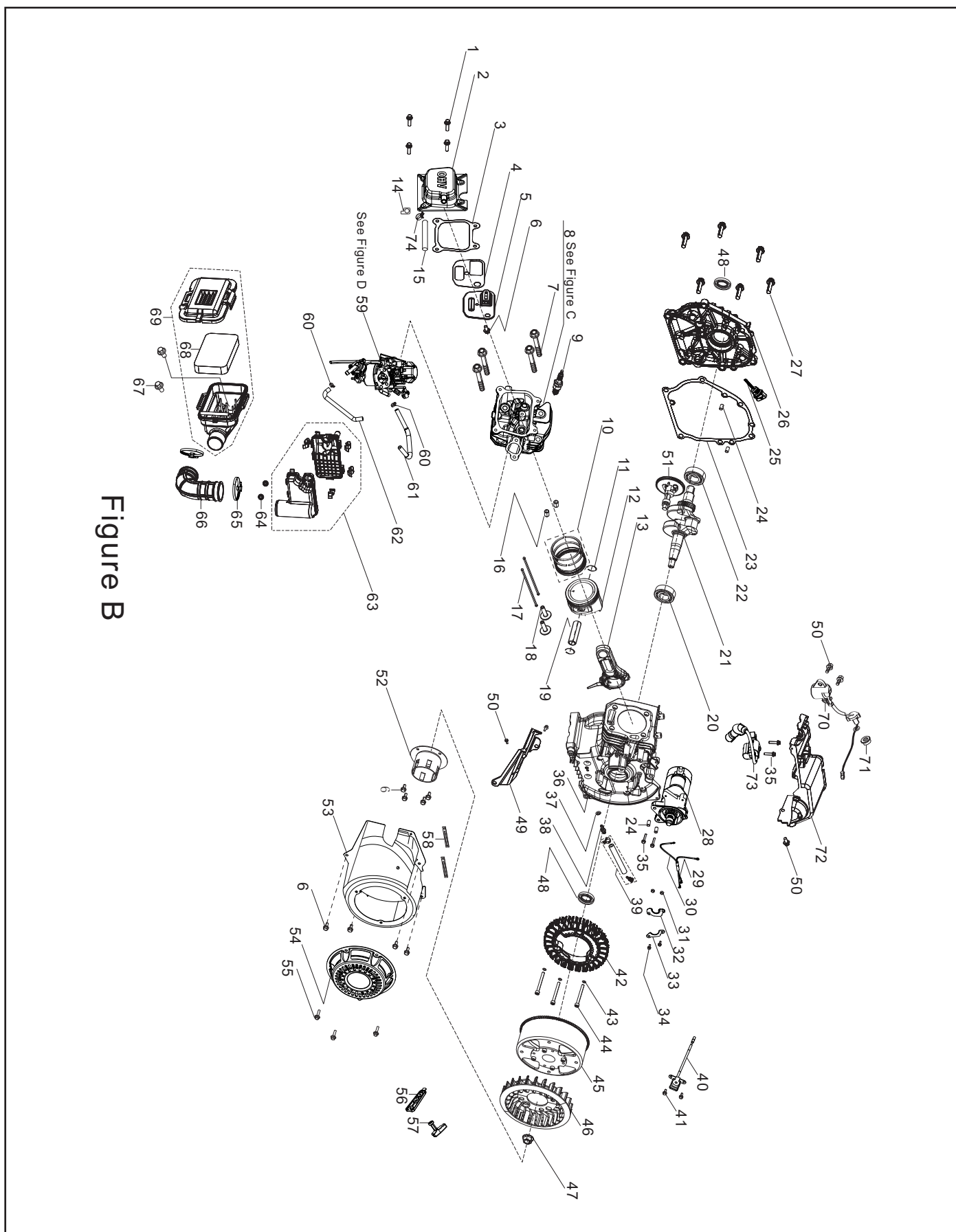

Figure B

## Engine Parts List

#	Part Number	Description	Qty.
1	90001-0620-01A0	Hexagon Flange Bolt, M6 x 20, White Zinc	4
2	12410-Z1D0111-00A0	Cylinder Head Cover Subassembly	1
3	12004-Z1D0110-00A0	Cylinder Head Cover Gasket	1
4	11332-Z1D0110-00A0	Gasket, Breath Groove Cover	1
5	11320-Z1D0110-00A0	Piece, Breath	1
6	90001-0612-01A0	Hexagon Flange Bolt, M6 x 12, White Zinc	9
7	12003-Z010110-00A0	Cylinder Head Bolt, M8 x 60, White Zinc	4
8	96003-ZSS2010-0000	Cylinder Head - See Figure C	1
9	30010-Z010110-00A0	Spark Plug, F6RTC	1
10	13200-Z140210-00A9	Piston Ring Assembly	1
11	13122-Z010110-00A0	Piston Pin Clip	2
12	13111-Z950120-00A0	Piston	1
13	13010-Z950110-00A0	Connecting Rod	1
14	90804-Y5Z0210-0001	Stop Block	1
15	17004-Z1D0110-00A0	Tube, Breather	1
16	90502-1114-00A0	Pin, Ø11 x 14	2
17	14071-Z950110-00A0	Valve Lifter	2
18	14081-Z040110-00A0	Valve Tappet	2
19	13121-Z010110-00A0	Piston Pin, Ø18 x Ø54	1
20	90547-6305-00A1	Bearing 1	1
21	13300-Z1D0110-00A1	Crankshaft Assembly	1
22	90547-0205-00A0	Bearing 2	1
23	11001-Z010120-00A0	Crankcase Gasket	1
24	90502-0812-00A0	Pin, Ø8 x 12	4
25	15010-Z010210-Q2A0	Oil Dipstick Subassembly	1
26	11411-Z1D0110-00A0	Crankcase Cover	1
27	90001-0832-01A0	Hexagon Flange Bolt, M8 x 32, White Zinc	6
28	30300-Z1D0210-0000	Starting Motor Assembly	1
29	31112HYH30310-00A0	DC Wire Harness, Battery	1
30	31114HYH30210-00A0	DC Wire Harness, Engine	1
31	90305-0500-31A0	Hexagon Flange Nut, M5, White Zinc	2
32	54066-YE50110-09A0	Wiring Clamp, White Zinc	1
33	30002-Z1D0110-00A0	Magneto Wiring Clamp	1

#	Part Number	Description	Qty.
34	90001-0520-01A0	Hexagon Flange Bolt, M5 x 20, White Zinc	2
35	90001-0628-01A0	Hexagon Flange Bolt, M6 x 28, White Zinc	4
36	11310-Z1D0110-00A9	Crankcase Subassembly	1
37	90408-Z010510-00A0	Flat Washer, Ø10 x Ø15.8 x 1.5	1
38	90689-Z430211-00A0	Joint, Fuel Pile, White Zinc	1
39	11011HZ1D0210-L4A0	Oil Drain Hose	1
40	30130-Z1D0310-0000	Trigger	1
41	90001-0516-01A0	Hexagon Flange Bolt, M5 x 16, White Zinc	2
42	30120-YMR0110-00A0	Stator Component, Ø152 x 38	1
43	90408-0600-E1A0	Washer, Ø6, White Zinc	3
44	90102-0660-06A0	Hexagon Socket Cap Screw, M6 x 60	3
45	30110-YH30110-00A0	Rotor Component	1
46	19352-Z1D0110-00A0	Cooling Fan, Engine	1
47	13501-Z010110-00A0	Flywheel Nut, M14 x 1.5, White Zinc	1
48	90682-Z010110-00A0	Oil Seal, Ø25 x Ø41.25 x 6	2
49	19309-Z1D0110-00A0	Right Shield, Crankcase	1
50	90001-0616-01A0	Hexagon Flange Bolt, M6 x 16, White Zinc	5
51	14200-Z1D0110-00A9	Camshaft Assembly	1
52	28002-Z1D0210-00A0	Starter Pulley	1
53	28110-Z1D0110-H600	Shroud	1
54	28200-Z1D0410-H600	Recoil Starter Assembly	1
55	90251-0608-03	Bolts and Washer Assembly	3
56	28004-YHX0110-Q200	Guide Plate, Starter Rope	1
57	28210-YEB0110-L400	Handle, Starter Rope	1
58	90684-Z030120-00A0	Clip, 100 mm	2
59	96003-ZSS7410-0000	Carburetor Assembly	1
60	90748-0812-00A0	Clamp, Ø8x12	2
61	90729-YEY0310-00A0	Hose, Ø6.3 x Ø13 x 260	1
62	90729-YEY0411-00A0	Hose, Ø6.3 x Ø13 x 210	1
63	17400-Z1D0112-00A0	Air Cleaner, Auxiliary	1

#	Part Number	Description	Qty.
64	90305-0600-31A0	Hexagon Flange Nut, M6, White Zinc	2
65	12081-Z1D0110-00A0	Clamp 1	2
66	12510-Z1D0110-00A1	Inlet Pipe	1
67	90001-0625-01A0	Hexagon Flange Bolt, M6 x 25, White Zinc	2
69	17100-Z1D0112-00A1	Air Cleaner	1
68	17151-Z1D0110-0000	Element, Air Cleaner	1
70	37060-Z1D0112-0000	Engine oil Sensor, W/O Nut	1
71	90305-Z010210-01A0	Hexagon Flange Nut, M10, White Zinc	1
72	16675-Z1D0112-00A0	Shield	1
73	30400-Z1D0311-0000	Ignition Coil	1
74	90685-Z120110-00A0	Clamp, Ø14	1

Engine Parts Diagram Figure C

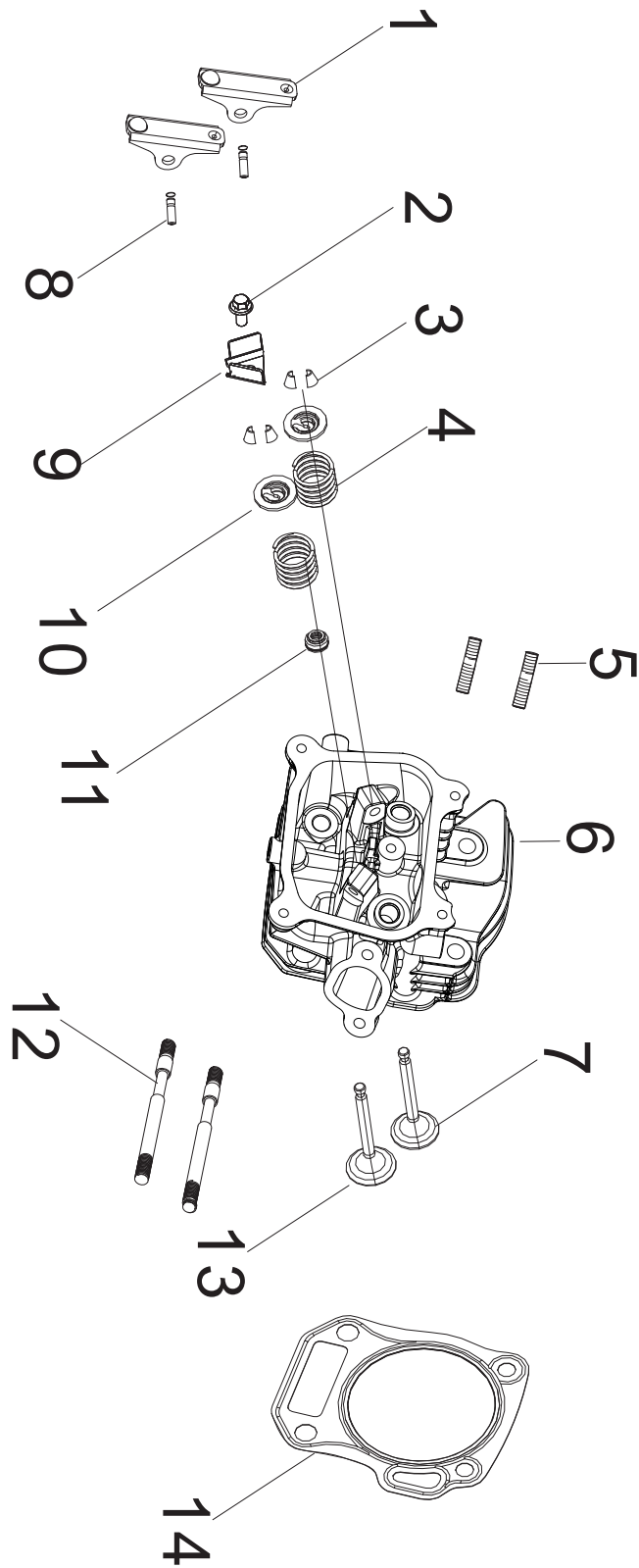

Figure C



## Engine Parts List

#	Part Number	Description	Qty.
1	14310-Z950110-00A0	Valve Rocker Subassembly	2
2	90001-0612-01A0	Hexagon Flange Bolt, M6 x 12, White Zinc	1
3	12109-Z810110-00A0	Valve Lock Clamp	4
4	12103-Z010110-00A0	Valve Spring	2
5	90203-Z010110-00A0	Stud, M8 x 34, Black Zinc	2
6	12140-Z950310-00A0	Cylinder Head Subassembly	1
7	12121-Z950110-00A0	Exhaust Valve	1
8	14318-Z950110-00A0	Valve Rocker Shaft Subassembly	2
9	12419-Z950311-00A0	Pin Plate, Cylinder Head Cover	1
10	12112-Z810210-00A0	Valve Spring Retainer	2
11	12101-Z810210-00A0	Seal Guide	1
12	90207-Z330210-00A0	Stud, M6 x 105, Black Zinc	2
13	12111-Z950110-00A0	Inlet Valve	1
14	12131-Z950210-00A0	Cylinder Head Gasket	1

Engine Parts Diagram Figure D

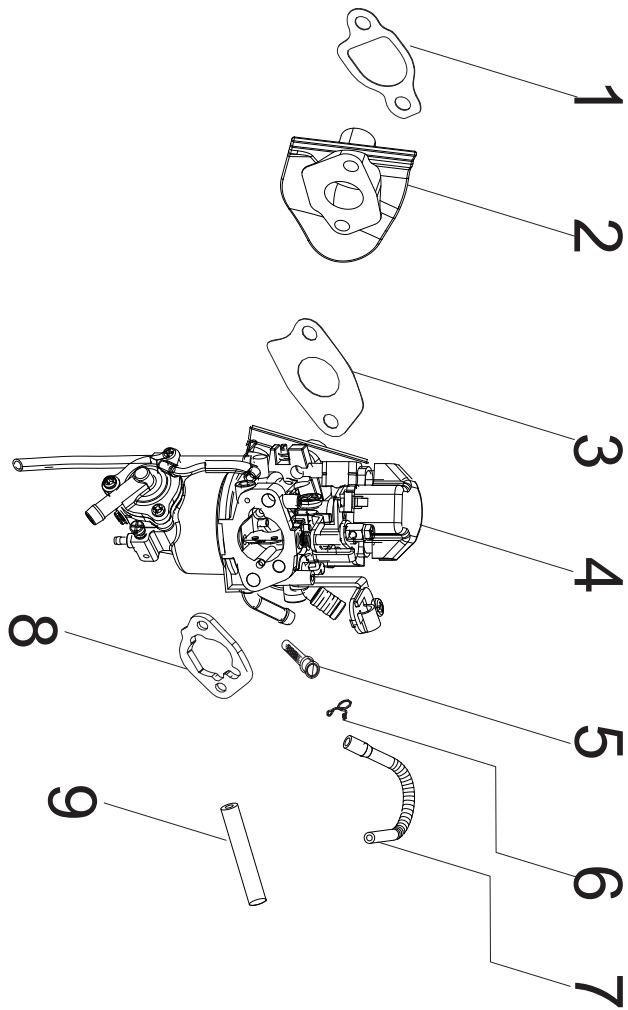
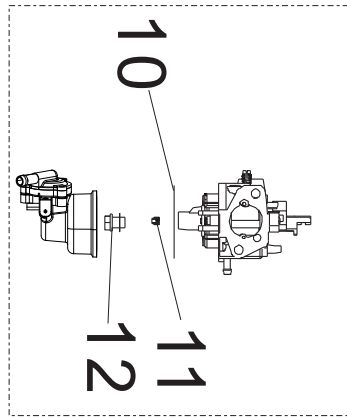

Figure D