

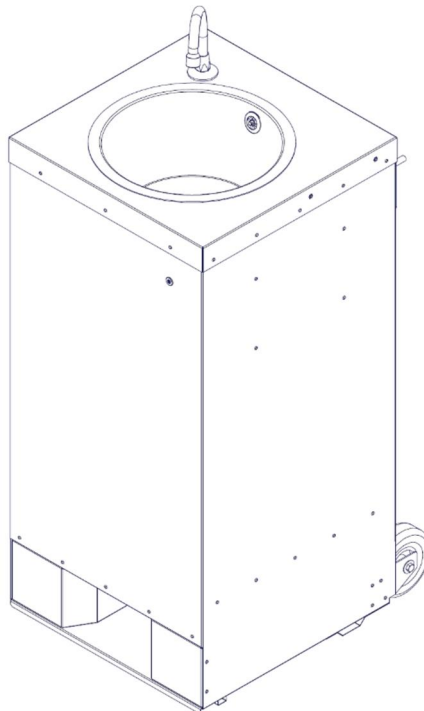

MOBILE HAND WASH UNIT

INSTALLATION, OPERATION & MAINTENANCE MANUAL

PLEASE LEAVE WITH OPERATOR



MOBILE HAND WASH UNIT – Series 1

Imperial Machine Company Limited
Unit 1, Abbey Road
Wrexham Industrial Estate
Wrexham LL13 9RF
Tel: +44 (0)1978 661155
Fax: +44 (0)1978 729990
Spares Fax: +44 (0)1978 667759
E-mail: service@imco.co.uk
E-mail: sales@imco.co.uk
Website: www.imco.co.uk

INDEX

INTRODUCTION	1
Guarantee	1
Delivery	1
SAMPLE RATING LABEL	2
DIMENSIONS.....	2
SPECIFICATION	2
INSTALLATION.....	5
Procedure	5
Location	5
Electricity Supply Connection	6
USING YOUR IMC MOBILE HAND WASH UNIT	7
Commissioning	7
Hand Washing	8
Emptying / Refilling	8
Cleaning	10
Descaling	10
MAINTENANCE	11
ADDITIONAL EXTRAS.....	11
WIRING DIAGRAM	12
SPARE PARTS	13
Spare Parts List	13
Ordering Spare Parts	13

INTRODUCTION

Congratulations on your purchase of the IMC Mobile Hand Wash Unit. Thoughtfully designed to allow the users to wash their hands at a safe comfortable temperature wherever there is a suitable power source available. This manual outlines the installation, operation and maintenance procedures relevant to this unit.

Guarantee

The Mobile Hand Wash unit is guaranteed by IMC for 2 years from the date of purchase from IMC, or from one of its stockists, dealers or distributors. The guarantee is limited to the replacement of faulty parts or products and excludes any consequential loss or expense incurred by purchaser

. Defects which arise from faulty installation, inadequate maintenance, incorrect use, connection to the wrong electricity supply or fair wear and tear are not covered by the guarantee.

The guarantee applies in this form to installations within the United Kingdom.

Please observe these instructions carefully.

Delivery

The packaged unit contains:

IMC MOBILE HAND WASH UNIT: Fully Assembled Hand Wash Unit	1
Splashback Panel*	1
Paper Tower Dispenser*	1
Soap Dispenser*	1
Instruction Booklet	1

* - Details can be found in the ADDITIONAL EXTRAS section of this document.

Please notify both the carrier and the supplier within three days of receipt if anything is missing or damaged.

Check that the correct machine has been supplied and that the voltage, marked on the rating plate, is suitable for the supply available. The rating plate is located on the right hand side of the case.

SAMPLE RATING LABEL

imc IMPERIAL MACHINE COMPANY Ltd			
LL13 9RF, UNITED KINGDOM TEL +44 (0)1978 661155			
MOBILE HAND WASH STATION		FREQUENCY(Hz) 50	
TYPE / MODEL	F63/500	IP RATING	IPX4
VOLTAGE RANGE	230	dB (A)	70
PHASE	1	AMPS (MAX)	12
SERIES #	1	kW (MAX)	3
SERIAL NUMBER = 6301190001			

www.imco.co.uk

DIMENSIONS

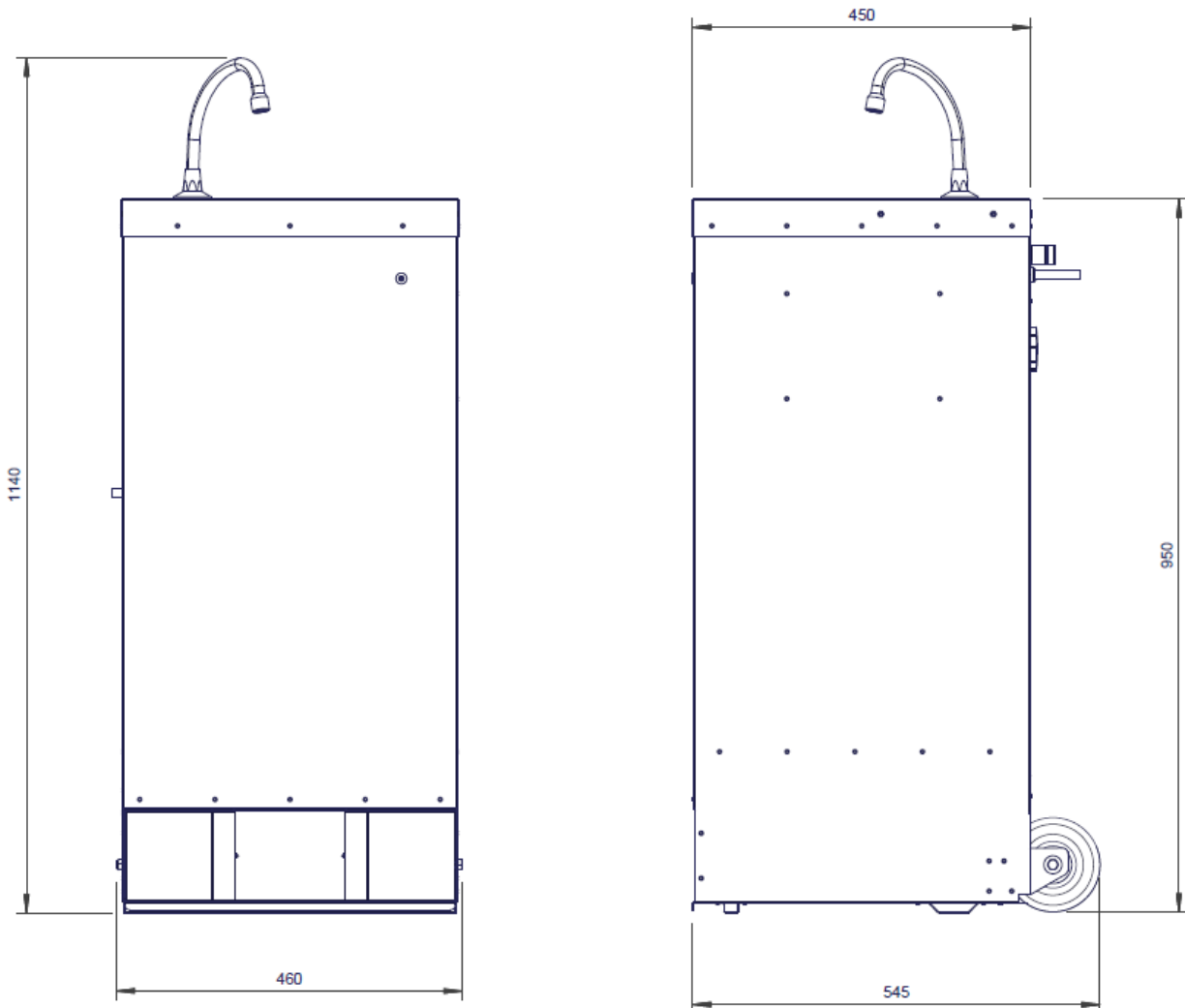

SPECIFICATION

Part No.	S63/200
Power rating	3 kW
Voltage	230 V ~50 Hz
Tank Capacity	10 litres
No. of hand washes per tank	85
Net Weight	30kg
Water Temperature	42 °C

PRODUCT FEATURES

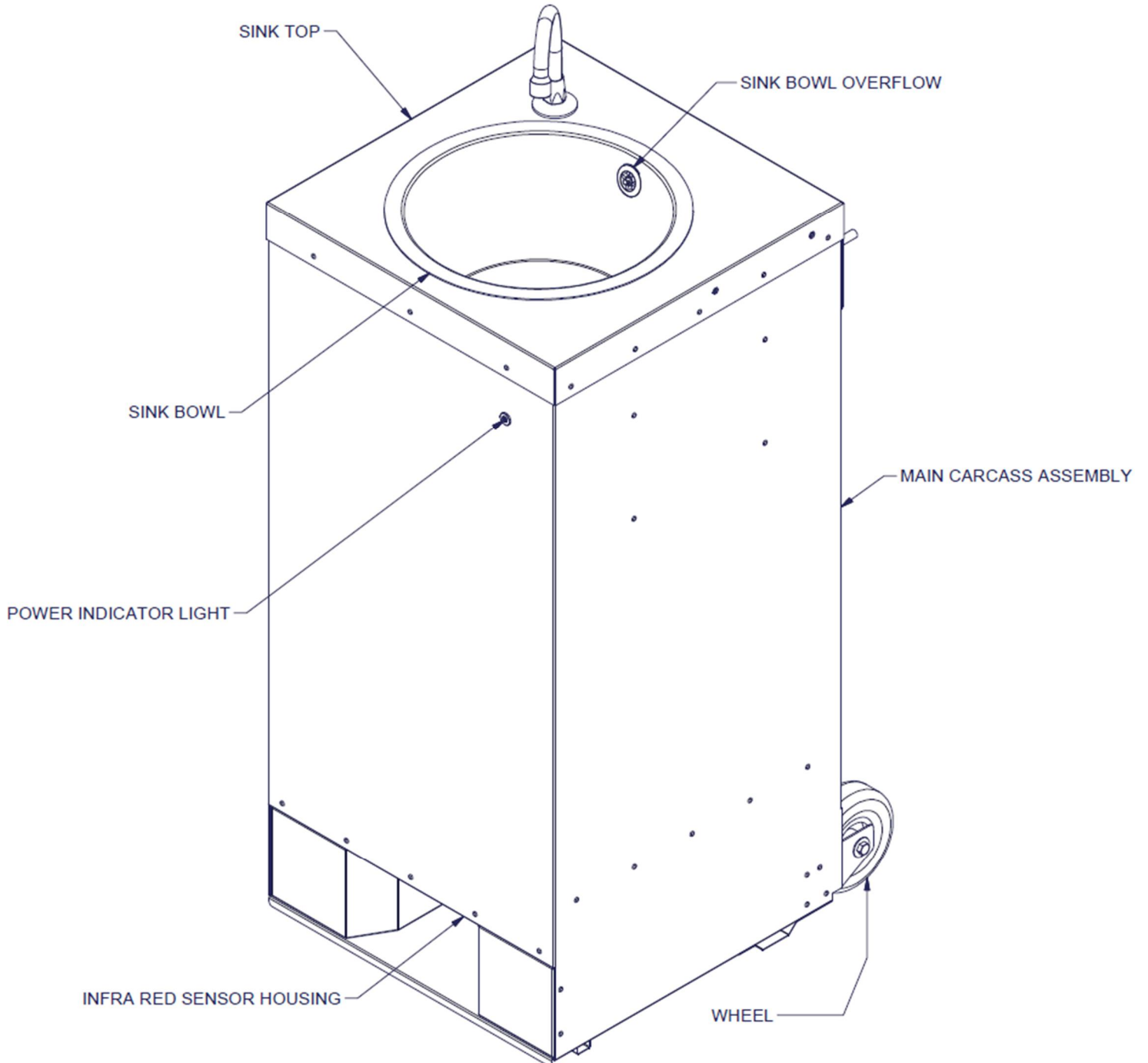

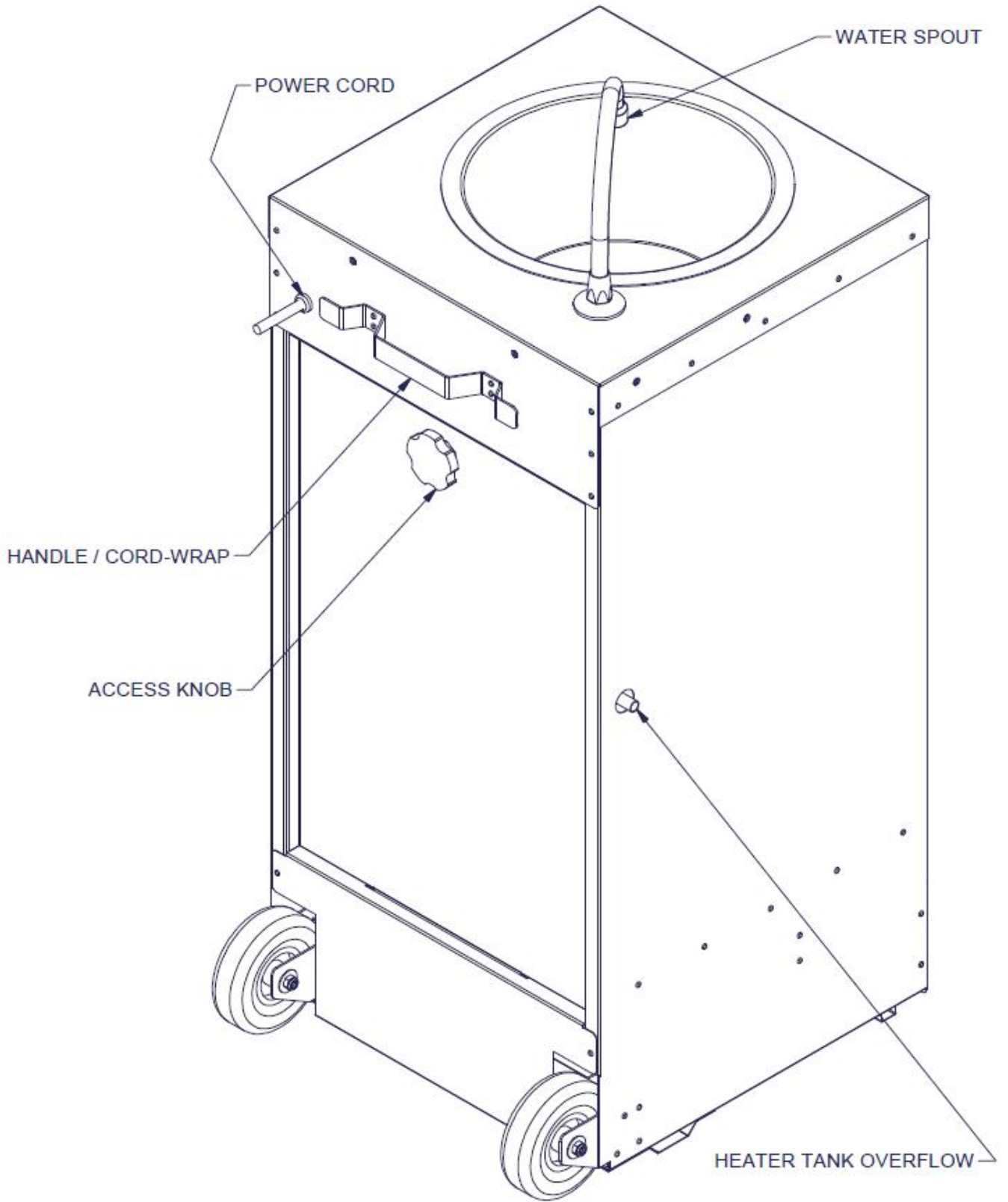

INSTALLATION

These Instructions contain important information designed to help the user obtain the maximum benefit from their investment in an IMC Mobile Hand Wash Unit.

Please read them carefully before starting work and consult with your distributor/supplier in the event of any queries.

Be sure to leave this Instruction Manual with the user after installation of the machine is complete.

Procedure**WARNING**

The following table shows the weight and the minimum quantity of people required to lift each unit:

	Net Weight	Quantity of People
IMC Mobile Hand Wash Unit	30 kg	2

Before connecting the unit to a power supply; remove all packaging and ensure that the unit is checked over for damage, any damage must be reported to the carrier or distributor/supplier immediately.

Remove any protective plastic coating on the unit.

Do not be alarmed if water is present in the tanks of the unit, this is normal and only a mere consequence of the rigorous testing procedures implemented here at IMC in Wrexham.

Location

The Mobile Hand Wash Unit is only suitable for use where there is no risk for the unit to be adversely affected by its surrounding environment or for the electrical components/connections to get wet.

The unit must be stationed on a flat surface capable of safely supporting the units weight when fully laden with water.

Ensure that the surface which the unit is to be stationed on is dry to avoid any water ingress into the lower electrical compartment.

Always ensure that the unit is unplugged before moving, move the unit using the handle on the back which also acts as a wrap bracket to hold the power cord in place when not in use.

The unit must be stationed at a reasonable distance from the power outlet socket so as not to put strain on the electrical connections, or causing a trip hazard. The power cord should not come in contact with any hot surfaces at any time.

Electricity Supply Connection

Position the unit at the chosen site, the electricity supply connection should be made to a power outlet socket or isolator mounted on the wall close to the machine. This socket or isolator must be accessible once the machine is installed. Before connecting, check that the voltage shown on the rating is correct for the electricity supply you have available. If the plug does not fit your sockets or a longer lead is required, changes must be made by an approved electrician.

NOTE: The plug is fitted with a 13amp fuse.

The plug fuse cover must be refitted when changing the fuse. In the event of losing the fuse cover the plug must NOT be used until a replacement fuse cover has been obtained and fitted or the plug replaced.

WARNING: This machine must be earthed!

Should the supply cord become damaged then a replacement must be fitted by an approved electrician. The IEE Codes of Practice must be observed.

The wires in the mains lead are coloured in accordance with the following code:

Green and yellow	Earth
Blue	Neutral
Brown	Live

USING YOUR IMC MOBILE HAND WASH UNIT**Commissioning**

Firstly, ensure that the unit is unplugged from any power source before following the steps outlined below.

Remove the back panel by unscrewing the black knob on the rear of the unit, tilt the panel backwards and pull away from the unit at an upward angle. This will enable the operator to gain access to the inner components of the unit.

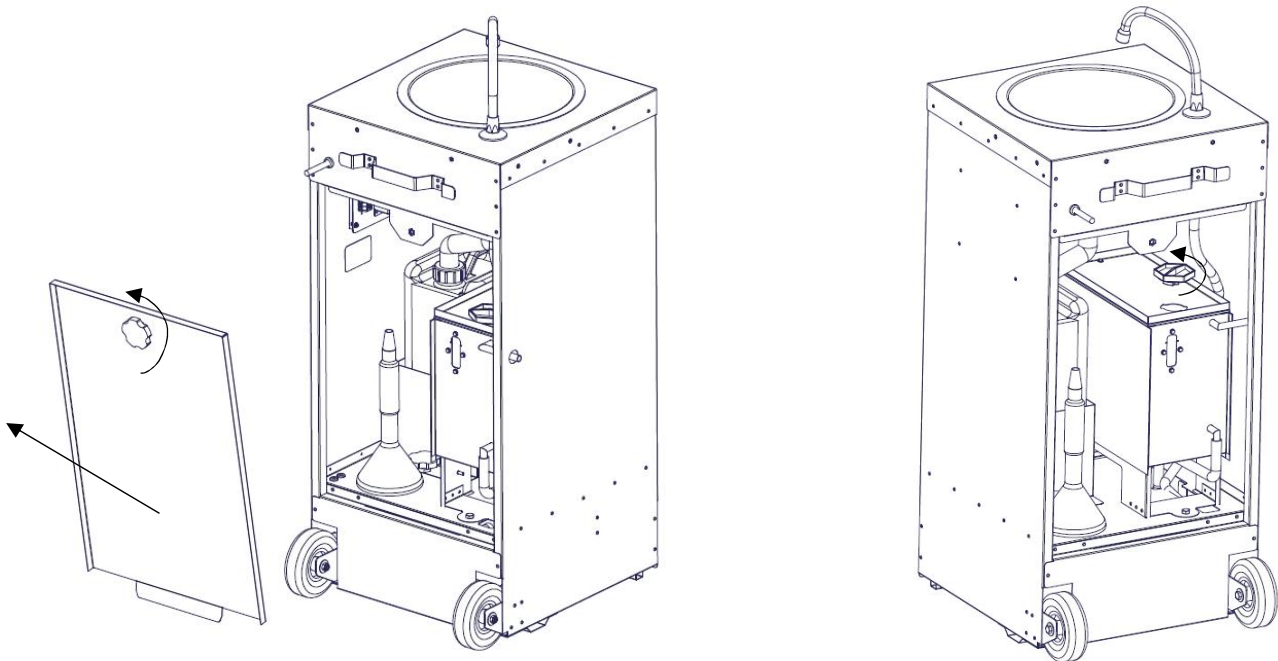

Once the rear panel has been removed, the hot water cap can be removed by twisting anti-clockwise. With the cap removed, the flexible plastic funnel supplied with the unit can be used to fill the tank up to the level shown on the fill level indicator on the tank. The filler cap can then be secured back in position.

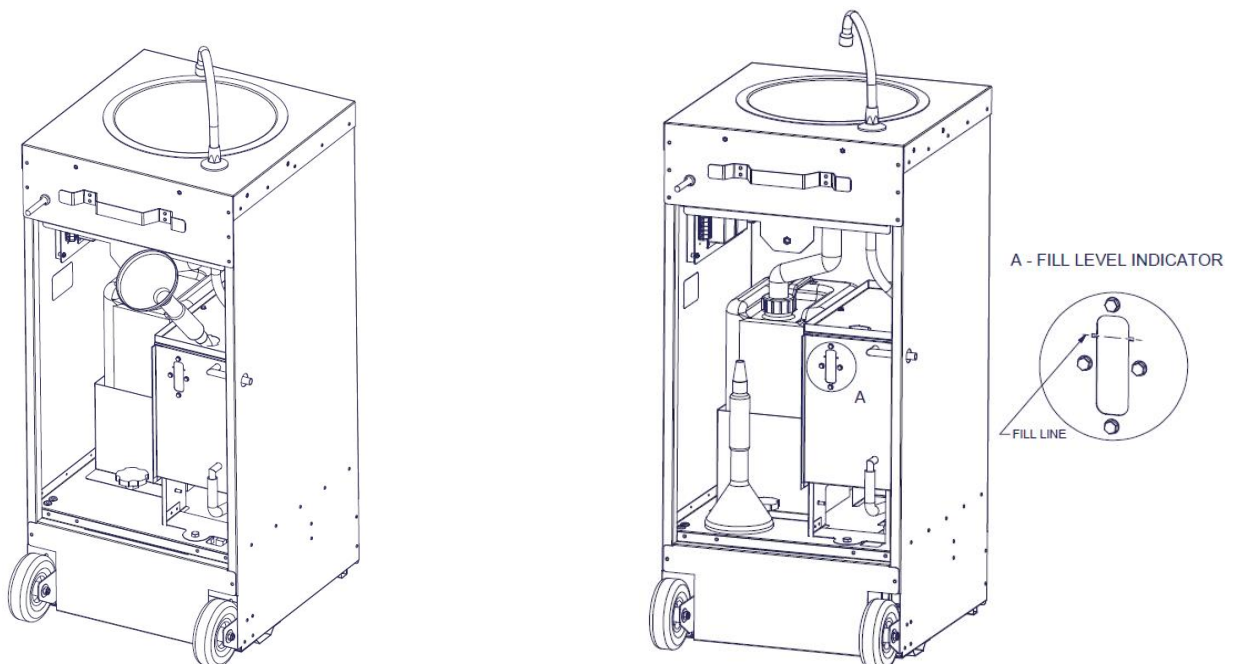

Power the unit up by connecting it to a suitable power source, the green light indicator on the front of the unit should light up once this is done. Once the unit has been connected, the element in the hot water tank will start heating up the water immediately; it should take approximately 15 minutes to reach operating temperature on a full tank of water.

The next step will be to prime the pump ready for operation. To do this; place your foot inside the infra-red housing located at the front of the unit, this should run the pump for 8 seconds. Repeat this step until water can be seen coming out of the spout located above the sink of the unit.

Once all of the above steps have completed, your Mobile Hand Wash Unit should now be ready for operation.

Hand Washing

To operate the unit; place your foot inside the infra-red sensor housing located at the front of the unit, this action will break the infra-red beam running across the housing and initiate a hand wash cycle; running the pump for 8 seconds. The pump will then not re-activate until the beam is reinstated and then broken again for the next hand wash cycle.

New hand wash cycles can be initiated until the hot water tank has reached its lower level, when this point is reached the wastewater tank must be emptied and the hot water tank refilled by following the steps outlined in the next section.

Emptying / Refilling

Once the unit has completed its total number of cycles, the waste water tank will need emptying before the hot water tank is refilled.

To empty the waste-water tank; remove the back panel from the and identify the plastic waste water tank on the rear left hand side of the unit. Place the flexible plastic funnel to one side, unscrew the plastic turn knob which holds the waste water retaining bracket in place and remove the bracket from the unit. The waste-water pipe can now be removed and the tank can be slid out of the unit and emptied appropriately.

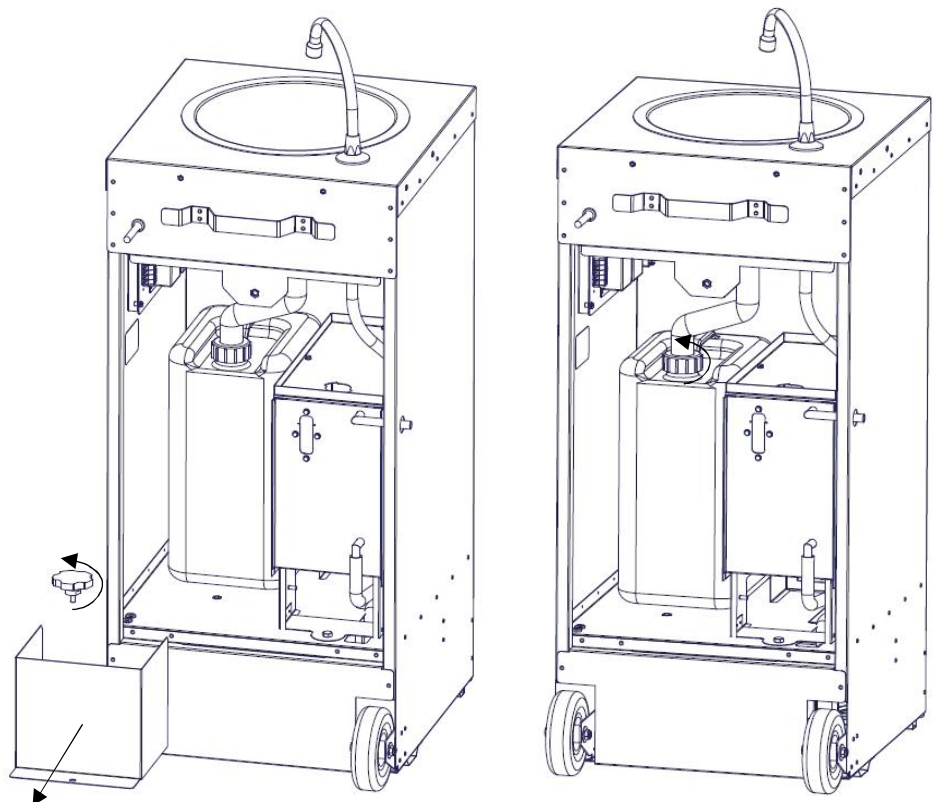

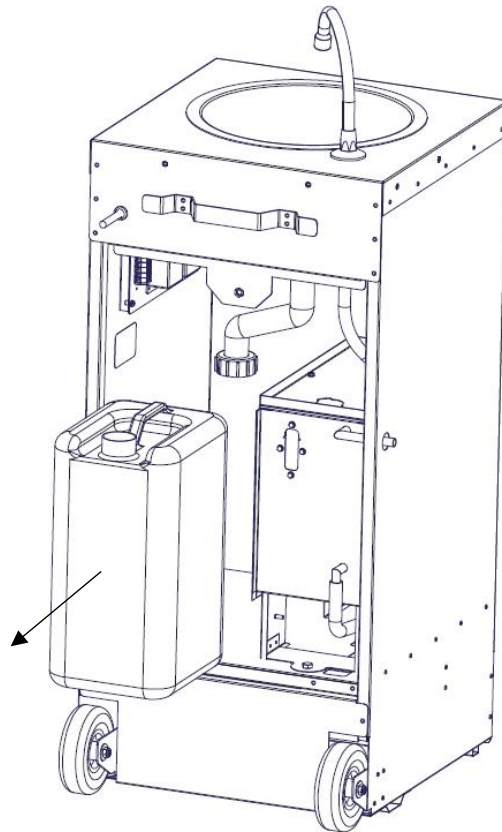

To re-install the waste-water tank, follow the above steps in reverse.

To refill the hot water tank, follow the steps outlined in the commissioning section.

Draining

When the unit is to be stored away or not used for the mid-long term, the hot water tank must be drained in order to reduce the risk of bacteria and other harmful organisms multiplying in the water reservoir. A drainage valve has been integrated in to the design of the tank which can be seen in the figure below.

To drain

Remove the flexible hose and place inside a suitable waste water container.

Open the tap and allow enough time for the water to flow out.

Close the tap and place the hose back in its stowing position.

Ensure that the waste water is disposed of appropriately.

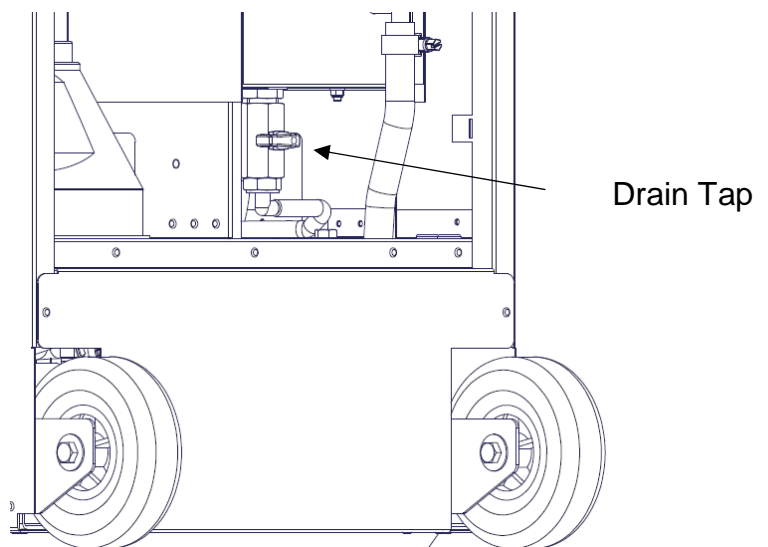

Cleaning

NOTE: This hand wash station is not waterproof and therefore must not be cleaned using a hose or any type of water jet equipment.

Clean the externals of the unit as required; using a damp cloth and an appropriate cleaning product.

DO NOT USE CLEANING MATERIALS CONTAINING ABRASIVES OR BLEACHES.

Descaling

In addition to regular cleaning the unit will also need to be descaled on a regular basis, the frequency of which depends on the hardness of the water being used. Descaling is required when calcium carbonate deposits are left on the water heating element and interior of the hot water tank after repeated use.

Use a propriety descaling product recommended for stainless steel kettles; follow all instructions provided with the descaling product. Upon using the descaling product, ensure that the hot water tank is filled with water, heated and emptied to ensure that no remnants of the product remain in the tank

MOBILE HAND WASH UNIT

11

MAINTENANCE



Warning

Never service, repair or troubleshoot a unit unless you are a professional and qualified to do so. Improper servicing can lead to serious injury or death from fire, electric shock or explosion.

It is recommended that the unit is serviced by an IMC approved engineer at least once a year.

Details of IMC Service Contracts are available on application.

ADDITIONAL EXTRAS

The IMC mobile hand wash unit is available with an optional splashback which is available in 4 different configurations (contact supplier/distributor for details).

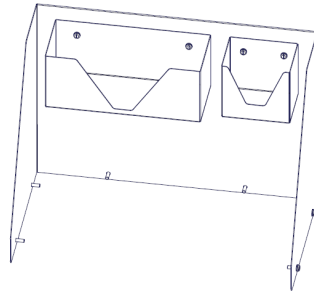

The splashback is simply fixed to the unit using six M5 screws which are supplied with the splashback when chosen as an optional extra. The figure below shows the height of the unit when the splashback is present.

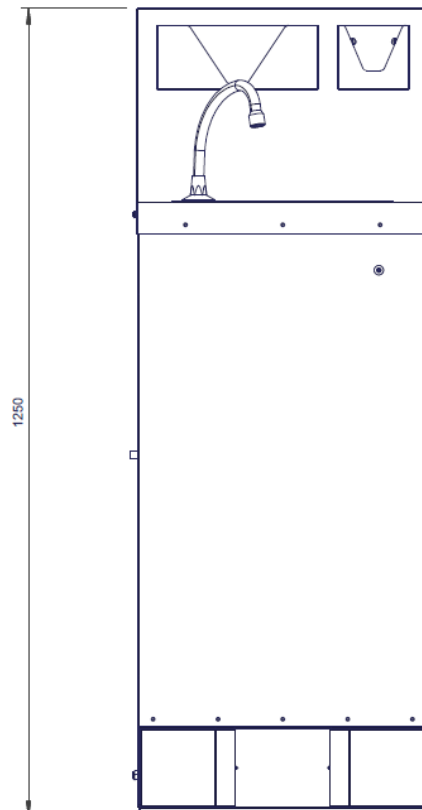
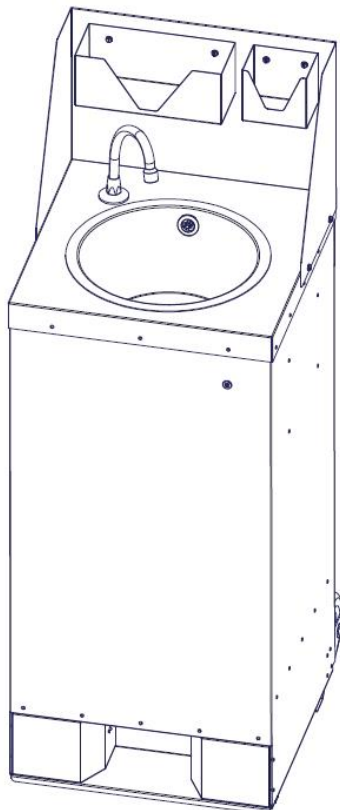

MOBILE HAND WASH UNIT 13

SPARE PARTS

Spare Parts List

PART NUMBER	QTY	DESCRIPTION
A10/497	1	WASTE WATER TANK 12 LTR
A10/498	1	PLASTIC FUNNEL WITH FLEXIBLE SPOUT
A13/156	1	HOT WATER TANK CAP & SEAL ASSY
A19/042	2	MOBILE HANDWASH WHEEL
A21/044	2	KNOB 2160_M M8 x 14 BLACK
E63/008	1	MOBILE HANDWASH REAR PANEL
E63/018	1	MOBILE HANDWASH WASTE WATER RETAINING BRACKET
G45/190 M1	1	THERMOSTAT ASSY
G45/191 M1	1	THERMAL CUT-OUT
G45/192 M1	1	WATER LEVEL SENSOR
G45/193 M1	1	TEMP PROBE MOUNT SEAL KIT
G50/186 M1	1	GREEN NEON LIGHT NE43
G55/040	1	PCB BOARD & MOTION SENSOR
G60/908 M1	1	PLUG & CABLE (UK)
G86/034	1	HEYCO CORD ANCHORAGE SR6N34 PT No1200
G95/040	1	MOBILE HANDWASH HEATER ELEMENT - EL277
G96/070 M1	1	WATER PUMP
J03/171	1	TAP ASSEMBLY
S63/210	1	MOBILE HANDWASH ELECTRICS PANEL ASSY COMPLETE
S63/213	1	MOBILE HANDWASH SENSOR ASSEMBLY
S63/217	1	MOBILE HANDWASH WATER HOSE KIT

Ordering Spare Parts

In the event that spare parts or accessories need to be ordered, please always quote the SERIES AND SERIAL NUMBER of the machine. This is to be found on the rating plate located near the supply cable.

For installations outside the UK please contact your supplier.

For information on IMC spares and service support (if applicable), please call IMC on +44 (0)1978 661155. Alternatively, contact us via email:

IMC Service Desk

E-mail: service@imco.co.uk

IMC Spares Desk

E-mail: spares@imco.co.uk

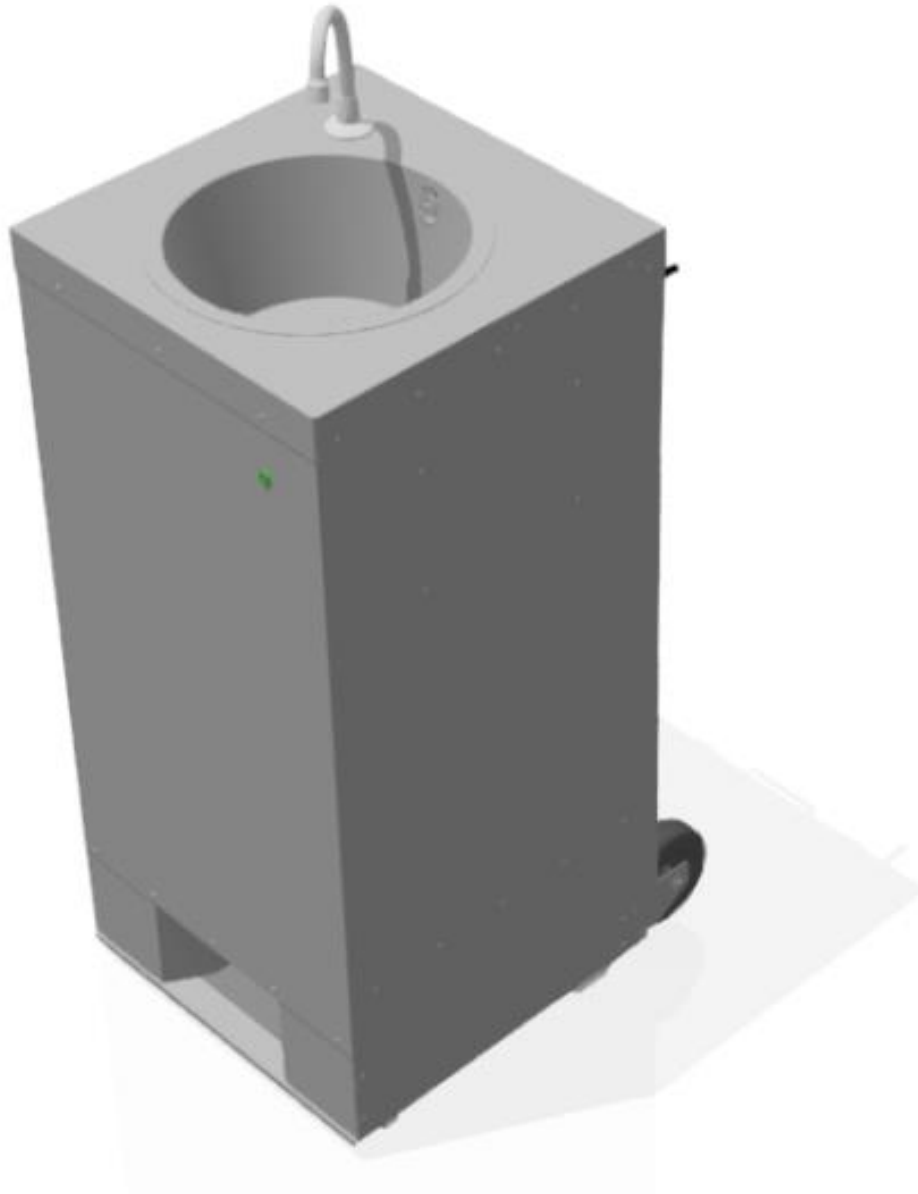
imc

Imperial Machine Company Limited
Unit 1, Abbey Road
Wrexham Industrial Estate
Wrexham LL13 9RF
Tel: +44 (0)1978 661155
Fax: +44 (0)1978 729990
Spares Fax: +44 (0)1978 667759
E-mail: service@imco.co.uk
E-mail: sales@imco.co.uk
Website: www.imco.co.uk