

HALLCO RHAMHWS+ MOBILE HAND WASH STATION USER MANUAL

PLEASE LEAVE WITH OPERATOR



Index

| | |
|----|--|
| P1 | Introduction, Warranty Information and Included Contents |
| P2 | Dimensions, Specification and Product Features |
| P3 | Installation and Safety Details |
| P4 | Commissioning |
| P5 | Emptying/Refilling and Cleaning |
| P6 | Spare Parts and Contact Information |

Introduction

Thank you for your purchase of the R H Hall Fabrications HALLCO RHAMHWS+ Mobile Hand Wash Station. This manual provides instruction for safe and proper use of the item.

Warranty

The RHAMHWS+ Mobile Hand Wash Station is sold with a 12 months warranty from date of purchase from R H Hall or from one of its approved dealers. The warranty is limited to the replacement of faulty parts or products and excludes any consequential loss or expense incurred by the purchaser. Defects which arise from faulty installation, inadequate maintenance, incorrect use or fair wear and tear are not covered by the warranty.

The warranty applies to goods installed within the United Kingdom only.

For Warranty Calls, please contact your Approved Dealer or the R H Hall Customer Service Team
01296 663400 – customerservice@rhhall.com

Contents

The RHAMHWS+ Mobile Hand Wash Station includes the following:

- Fully Assembled Hand Wash Unit with Tap & Foot Pump x1
- Splashback Panel x1
- Paper Tower Dispenser x1
- Soap Dispenser Holder x1
- 20 Litre Water Container x1
- 25 Litre Waste Container x1
- 6 Litre Waste Bin x1
- Door Key x1
- Anti slip pads (Optional to fit) x4
- User Manual x1

Please notify R H Hall or your approved dealer on the day of receipt if anything is missing or damaged.
01296 663400 or sales@rhhall.com

The data plate containing model number and serial number details is located inside the rear door of the machine.

Dimensions and Specification

| | |
|----------------------------------|-------------------------------------|
| Overall External Dimensions (mm) | 603 W 455 D 1145 H (inc splashback) |
| Water Capacity | 20 Litres |
| Waste Capacity | 25 Litres |
| Bowl Size | 260mm O/D |
| Net Weight | 29KG Approx. (when empty) |
| Electrical Requirement | None |

Product Features

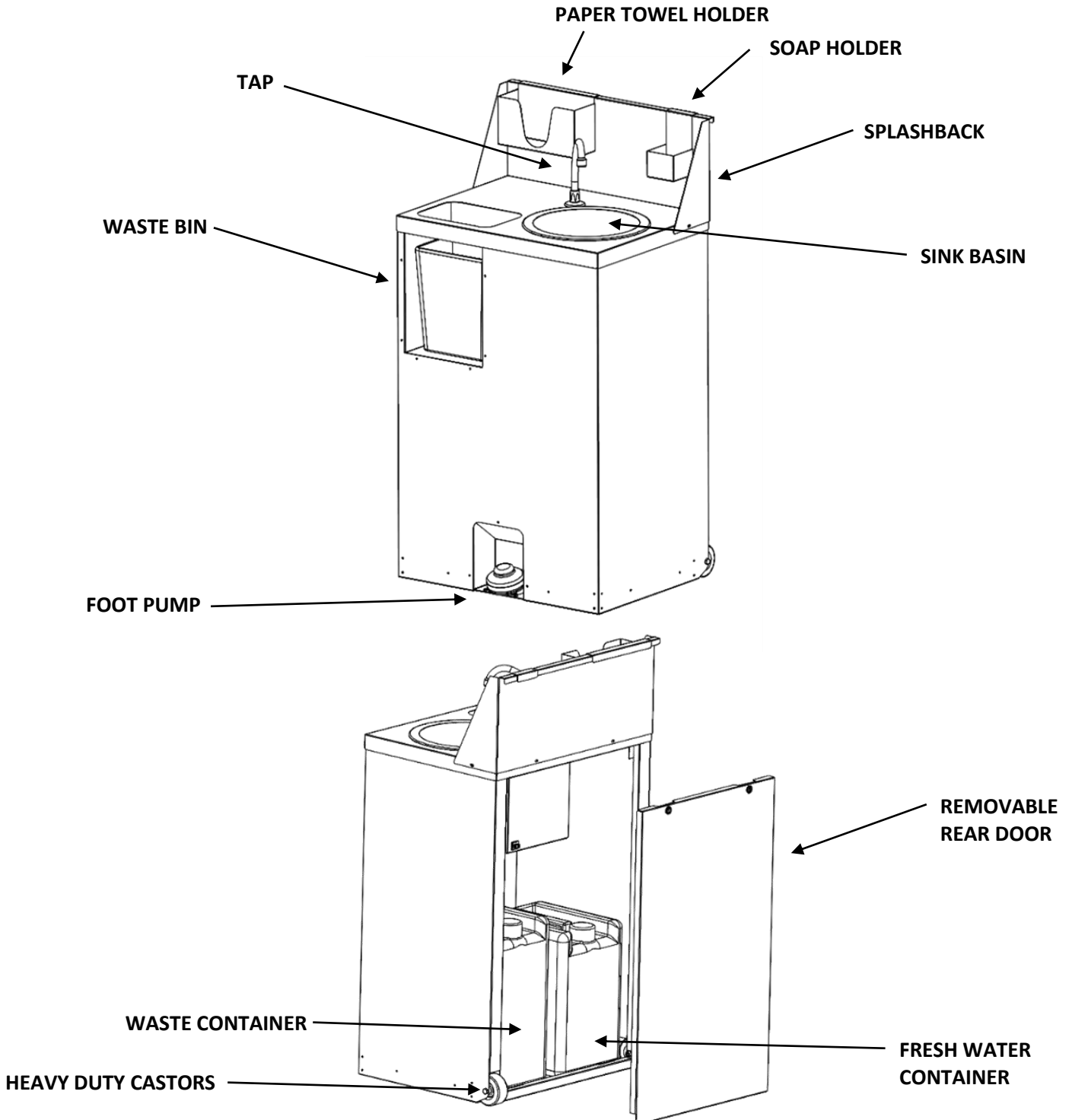

Installation

These Instructions contain important information designed to help the user obtain the maximum benefit and safe operation of their RHAMHWS+ Mobile Hand Wash Station

Please read through carefully before use and consult with the manufacturer or your approved dealer in the event of any queries.

Be sure to leave this User Manual with the operator after installation of the unit is complete.

WARNING

The following table shows the weight and the minimum quantity of people required to lift each unit:

| | Net Weight | Required People |
|-----------------------------------|----------------------|-----------------|
| RHAMHWS+ Mobile Hand Wash Station | Approx. 29kg (empty) | 2 |

Before using the hand wash; remove all packaging and ensure that the unit is checked over for damage, any damage must be reported to the carrier and manufacturer/approved dealer immediately. Failure to report damage within 24 hours may lead to any claim becoming null and void.

Remove any protective plastic coating on the unit.

Do not be alarmed if water is present in the tanks or pipes of the unit, this is normal and part of quality control procedures.

The Mobile Hand Wash Station should only be moved when both fresh water and waste containers are empty. Tilt the unit back slightly from the rear and use the castors to move on a flat surface.

Location

The Mobile Hand Wash Station is only suitable for use where there is no risk for the unit to be adversely affected by its surrounding environment.

The unit must be stationed on a flat surface capable of safely supporting the unit weight when fully laden with water.

The unit is fitted with a heavy duty rear castors, 140KG capacity per wheel.

Commissioning

Remove the rear panel by unlocking the two rear door locks with the key provided and lift the door out. This will enable the operator to gain access to the clean and waste water containers inside the unit.

Once the rear panel has been removed, lift out the suction hose from the clean water container and remove the water container. Note the water container can hold a maximum of 20 litres. Ensure when refitting the water container that the suction hose has been placed near the bottom of the container.

We advise that you operate the foot pump and pass water through the unit before refitting the rear panel. Before you do this though, please ensure the waste pipe is inside the 25 Litre waste container. To prime the pump ready for operation and pass water through the unit; place your foot inside the housing above the pump. Depress the foot pump several times until water is seen coming out of the spout located above the sink on the unit.

Once all of the above steps have completed and the rear panel has been refitted, your Mobile Hand Wash Station should now be ready for operation.

Emptying/Refilling

Once the unit has completed its total number of operations, the waste water container will need emptying and the clean water tank refilled.

To empty the waste water container; remove the rear panel. The waste-water pipe can now be removed and the container can be slid out of the unit and emptied appropriately.

To re-install the waste water container, follow the above steps in reverse.

To refill the clean water container, follow the steps outlined in the commissioning section.

Cleaning

Clean the outside of the unit as required, using a damp cloth and an appropriate cleaning product.

DO NOT USE CLEANING MATERIALS CONTAINING ABRASIVES OR BLEACHES.

Ordering Spare Parts

In the event that spare parts or accessories need to be ordered, please always quote the serial number located inside the rear door of the machine. Please provide this information to your Approved Dealer or the R H Hall Spares Team

01296 663400 – spares@rhhall.com

For further information on please call R H Hall on 01296 663400 Alternatively, contact us via email:

R H Hall Sales Team – sales@rhhall.com

R H Hall Customer Service Team – customerservice@rhhall.com

R H Hall Spares Team – spares@rhhall.com

We hope you are completely satisfied with your purchase!



R H Hall, Hallco House, Beacon Court, Pitstone Green Business Park, Pitstone, LU7 9GY
T: 01296 663400 F: 01296 663401 E: sales@rhhall.com W: www.rhhall.com