

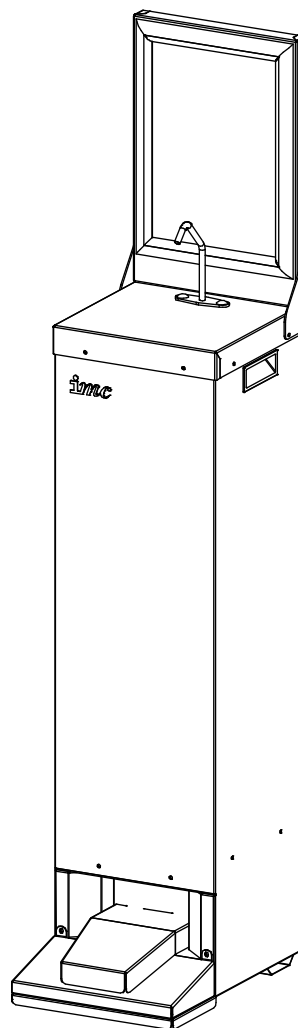

**HAND SANITISING STATION**

**INSTALLATION AND USER MANUAL**

**PLEASE LEAVE WITH OPERATOR**



**HAND SANITISING STATION – F63/250**

## INDEX

<b>IMPORTANT INFORMATION</b>	1
Guarantee	1
Delivery	1
<b>DIMENSIONS</b>	2
<b>SPECIFICATION</b>	2
<b>PRODUCT FEATURES</b>	3
<b>INSTALLATION</b>	4
Procedure	4
Location	4
Commissioning	5
Emptying / Refilling	6
Cleaning	6
<b>SPARE PARTS</b>	
Spare Parts List	6
Ordering Spare Parts	6
	6

**IMPORTANT INFORMATION**

Read these instruction carefully. This manual outlines the installation, operation procedures relevant to this unit.



**WARNING**

The unit should be used under adult supervision

**Guarantee**

The Hand Sanitising Station unit is guaranteed by Lincat-IMC for 1 year from the date of purchase from Lincat-IMC, or from one of its stockists, dealers or distributors. The guarantee is limited to the replacement of faulty parts or products and excludes any consequential loss or expense incurred by purchaser. Defects which arise from faulty installation, inadequate maintenance, incorrect use or fair wear and tear are not covered by the guarantee.

The guarantee applies in this form to installations within the United Kingdom.

Please observe these instructions carefully. Keep this manual for future reference

The manufacturer disclaims any liability for incidental, or consequential damages. Attendance is based on reasonable access to the appliance to allow the authorised technician to carry out the warranty work.

**Delivery**

The packaged unit contains:

IMC HAND SANITISING STATION: Fully Assembled Hand Sanitising Station Pump cover panel (removable) Rear upstand A4 click frame fitted	1
Instruction Booklet	1

Please note this unit is not supplied with Sanitiser.

Please notify **LINCAT-IMC** on the day of receipt if anything is missing or damaged.

**☎ UK: 01522 875555**

Check that the correct machine has been supplied. The data plate is located on the rear of the unit.

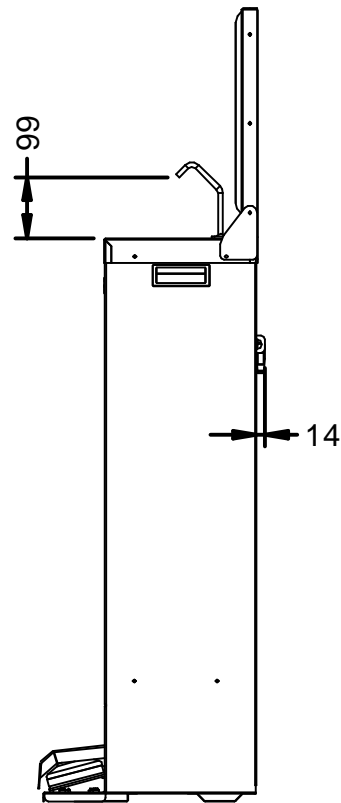
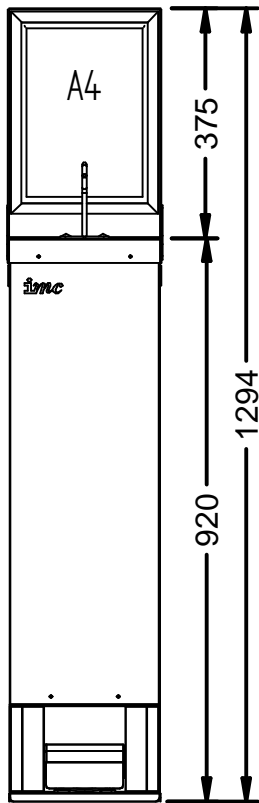
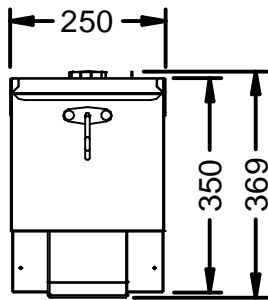

## DIMENSIONS

## SPECIFICATION

Sanitiser container compatible	5 litres
Net Weight	12.2kg

PRODUCT FEATURES

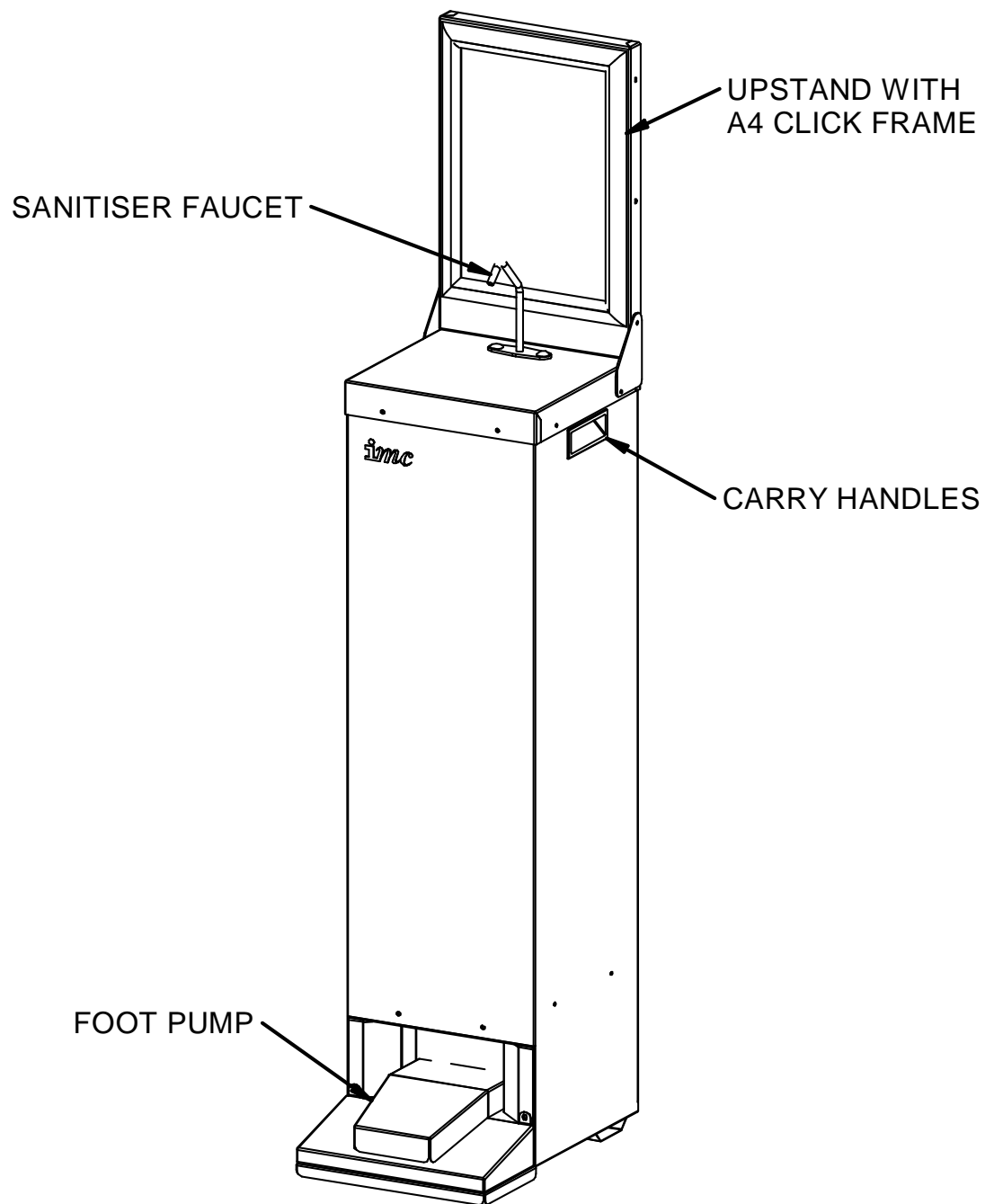

**INSTALLATION**

These Instructions contain important information designed to help the user obtain the maximum benefit from their investment.

Please read them carefully before starting work and consult with your distributor/supplier in the event of any queries.

Be sure to leave this Instruction Manual with the user after installation of the machine is complete, or in a safe location.

**Procedure****WARNING**

The following table shows the weight and the minimum quantity of people required to lift the unit:

	Net Weight	Quantity of People
F63/250	12.2kg	1

Before use; remove all packaging and ensure that the unit is checked over for damage, any damage must be reported to the carrier or distributor/supplier immediately.

Remove any protective plastic coating on the unit.

**Location**

The Hand Sanitising Station is only suitable for use where there is no risk for the unit to be adversely affected by its surrounding environment.

The unit must be stationed on a flat surface capable of safely supporting the units weight when fully laden with sanitiser.

The unit is fitted with a handles on the side to assist when moving.

## Commissioning

Remove the rear panel by unscrewing the black knob on the back of the unit, tilt the panel backwards and pull upwards away from the unit at an upward angle. This will enable the operator to gain access to the suction hose and place a suitable containers inside the unit.

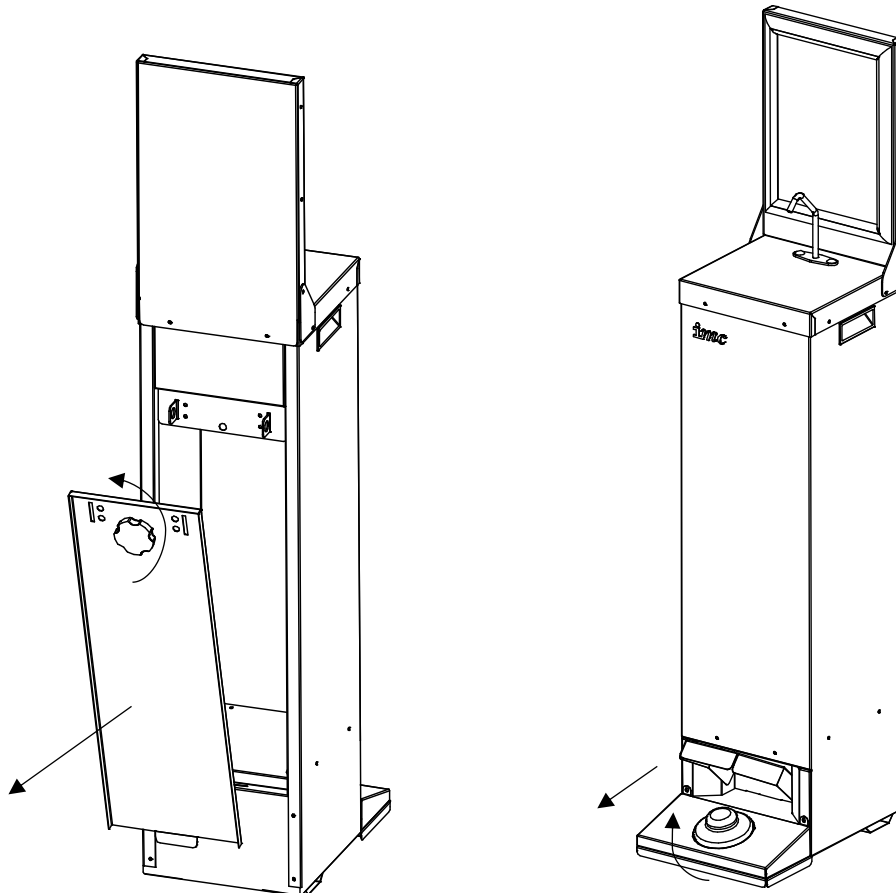

Once the rear panel has been removed, fit the suction hose pipe into the sanitiser container. Place the container on to the inner base panel. Note the suction tube is suitable for 5 litre containers.

The rear panel can now be refitted. Note there are two securing brackets through the back panel. These can be used to secure the back panel and the unit if being left unattended.

To prime the pump remove the pump cover panel. To do this lift upwards and away from the unit. Depress the foot pump several times until sanitiser is seen coming out of the dispense spout.

Once all of the above steps have completed the pump cover panel can now be refitted, your station should now be ready for operation.

Note the pump cover is required to restricts the volume of sanitiser dispensed per operation. This should only be removed to prime the unit with sanitiser.

**Emptying / Refilling**

Once the unit has completed its total number of operations, the sanitiser container will need replacing or refilled.

To replace the sanitiser container, follow the steps outlined in the commissioning section.

**Cleaning**

Clean the externals of the unit as required; using a damp cloth and an appropriate cleaning product.

***DO NOT USE CLEANING MATERIALS CONTAINING ABRASIVES OR BLEACHES.***

**SPARE PARTS**

PART NUMBER	DESCRIPTION
WP02	FOOT PUMP
A21_044	SECURING KNOB
CF01	A4 CLICK FRAME

**Ordering Spare Parts**

In the event that spare parts or accessories need to be ordered, please always quote the SERIES AND SERIAL NUMBER of the machine. This is to be found on the rating plate located near the supply cable if applicable or at the rear of the appliance.

For help with the installation, maintenance and use of your **Lincat - IMC** equipment, please contact our service department:

**☎ UK: 01522 875520**

For non-UK customers, please contact your local Lincat dealer

All service work, other than routine cleaning should be carried out by one of our authorised service agents. We cannot accept responsibility for work carried out by other persons.

To ensure your service enquiry is handled as efficiently as possible, please tell us:

- Brief details of the problem
  - Product code
  - Type number
  - Serial number
- } All available on serial plate

Lincat reserve the right to carry out any work under warranty, given reasonable access to the appliance, during normal working hours, Monday to Friday, 08:30 to 17:00.