



Installation, Operating and Servicing Instructions

Silverlink 600 Free Standing Gas Fryers J5 – A008, J10 – A008

Please make a note of your product details for
future use:

Date Purchased: _____

Model Number: _____

Serial Number: _____

Dealer: _____

SILVERLINK 600

CONTENTS

Important Information	2
Warnings and Precautions	3
Technical Data	4
Checklist of Enclosures	4
Installation and Commissioning	5-7
Operating Instructions	8-10
Cleaning	11
Servicing, Maintenance and Component Replacement	11-13
Fault Finding	14-17
Spare Parts List	18
Service Information and Guarantee	19
Notes	20

IMPORTANT INFORMATION



Read these instructions carefully before using this product, paying particular attention to all sections that carry warning symbols, caution symbols and notices. Ensure that these are understood at all times.



WARNING!

This symbol is used whenever there is a risk of personal injury.



CAUTION!

This symbol is used whenever there is a risk of damaging your Lincat product.

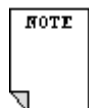

NOTE:

This symbol is used to provide additional information, hints and tips.

KEEP THIS MANUAL FOR FUTURE REFERENCE

WARNINGS AND PRECAUTIONS



Only qualified or trained personnel should use this appliance.

Parts protected by the manufacturer shall not be adjusted by the user.

Do not leave the appliance unattended whilst operating.

Do not operate with dust cover in place.

Do not obstruct or block the flue.

All equipment must be earthed to prevent shock.

During operation parts may become hot - avoid accidental contact.

Install a suitable fire extinguisher and fire blanket within reach of the appliance.

Do not use flammable solvents and cleaning aids.

Strip plastic coating and clean the appliance before use.

This unit is designed to be used with oils and fats in a liquid form.

Oils and fats that become solid at lower temperatures must be liquefied prior to dispensing into the fryer tank.

Old oil has a reduced flashpoint and is more prone to surge boiling.

Do not operate without oil in the tank.

Do not over heat the oil.

Care must be taken when replenishing the oil during service.

Oil should be filtered regularly.

This instruction includes both filling from empty and topping up during use.

This appliance is designated Category 1 and is not intended for conversion between gas types. Certified types I_{2E}, I_{2H}, I_{2L}, I_{3B/P} & I_{3P}.

TECHNICAL DATA

	J5	J10
Height (mm)	1050	1050
Width (mm)	300	600
Depth (mm)	750	750
Weight (kg)	46	75
Inlet connection	R _{1/2} (1/2" BSP)	
Gross heat input – Natural (kW)	12	24
Gross heat input – Propane (kW)	12	24
Gross heat input – Butane (kW)	12.5	25
Supply pressure – Natural (mbar)	20	20
Supply pressure – Propane (mbar)	37 - 50	37 - 50
Supply pressure – Butane (mbar)	30	30
Burner pressure – Natural (mbar)	20	20
Burner pressure – Propane (mbar)	37	37
Burner pressure – Butane (mbar)	28-30	28-30
Injector size – Natural (mm)	1.8	1.8
Injector size – Propane (mm)	1.2	1.2
Injector size – Butane (mm)	1.2	1.2
Gas consumption – Natural (m ³ h ⁻¹)	1.14	2.28
Gas consumption – Propane (kg h ⁻¹)	0.86	1.72
Gas consumption – Butane (kg h ⁻¹)	0.91	1.82
Maximum cooking load per basket (kg)	1.5	1.5
Tank capacity to upper level (litres)	12	12

CHECK LIST OF ENCLOSURES

Warranty card
Instructions manual
Baskets
Stability kit (J5 only)
Lid knob
Drain pipe

INSTALLATION AND COMMISSIONING

This appliance must be installed, commissioned, serviced and converted by a qualified person in accordance with national and local regulations in force in the country of installation.

Install this appliance on a level surface ensuring all vents are unobstructed. Minimum distances – see Fig 1, A 50mm B 1000mm.

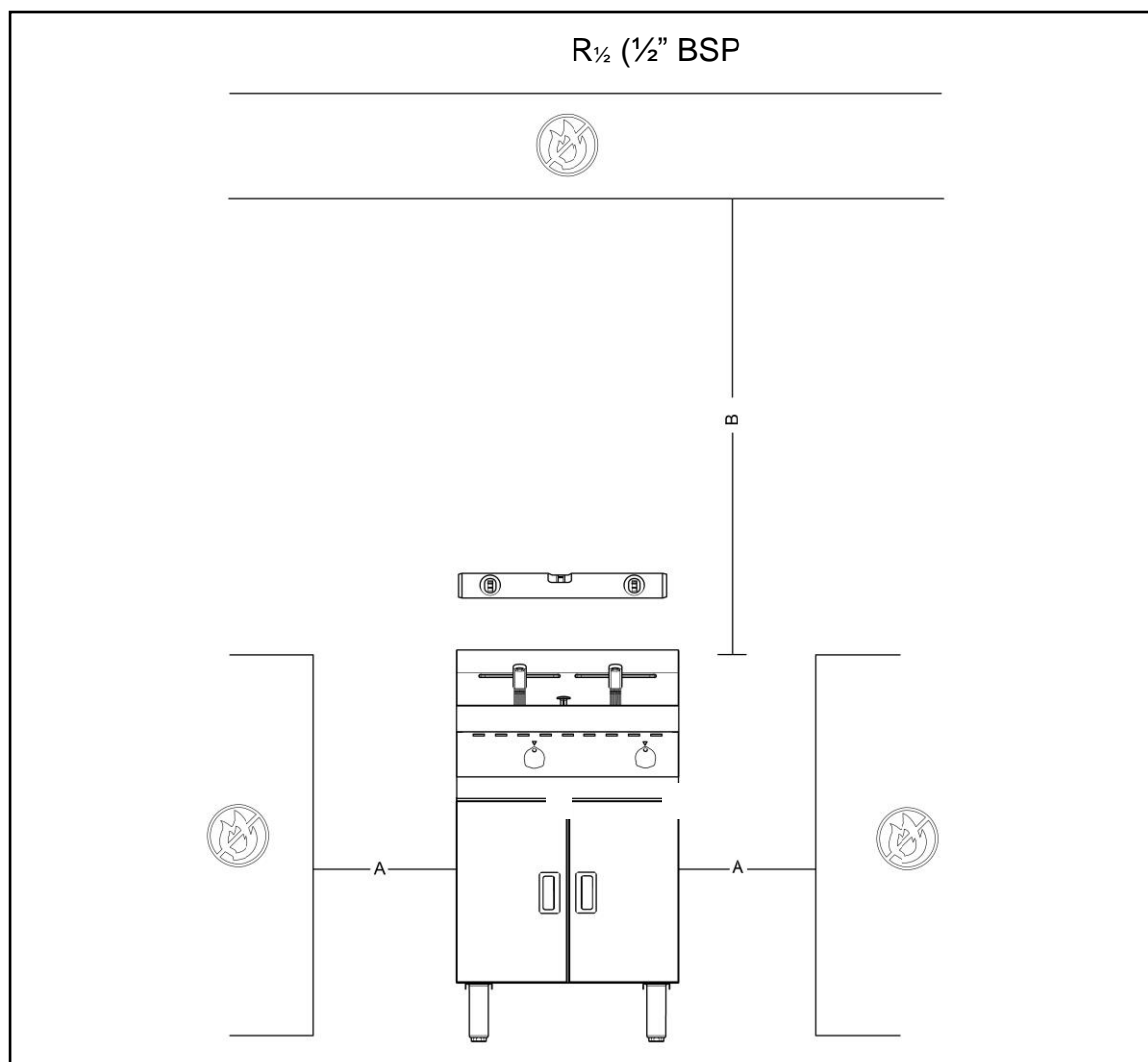

Fig 1

Site this appliance beneath an extraction canopy for the removal of combustion products.

Installation must include sufficient ventilation to prevent the occurrence of unacceptable concentrations of substances harmful to health in the room of installation. There must be a minimum free area of 4.5cm² per kW of total heat input.

Allow for a sufficient flow of fresh air for complete gas combustion.

Do not connect directly to any flue, ducting or mechanical extraction system.

The gas supply hose or tubing shall comply with national requirements in force and shall be periodically examined and replaced as necessary.



An equipotential bonding terminal is provided to allow cross bonding with other equipment.

When making the connection to the supply, secure the hexagon on the rear fitting to prevent rotation of internal pipe work.

Stability kit –fixing procedure Fig 2

The J5 model must be suitably fixed to the floor with the brackets provided.

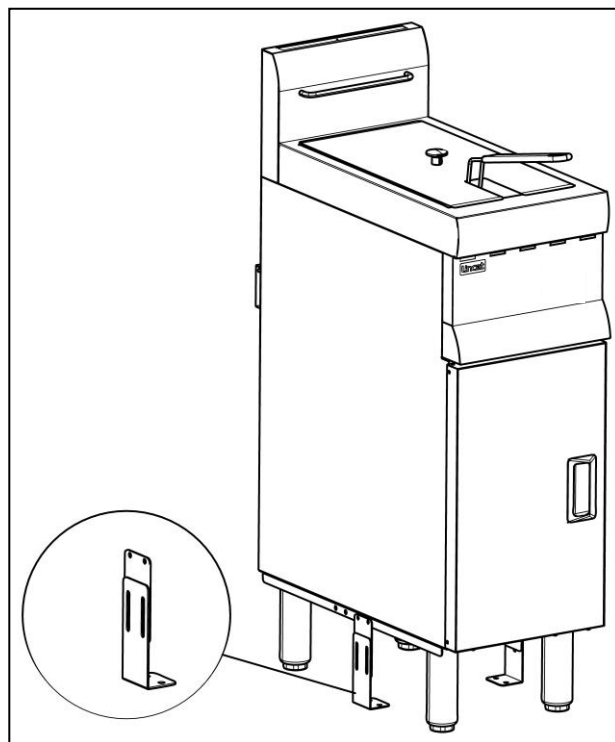

Fig 2

Site the appliance in its intended position. Fit the upper brackets to the bottom of the appliance using the screws provided.

Loosely fitting the lower brackets to the upper brackets, mark the floor through the holes in the lower brackets.

Drill the floor as marked with a 7mm drill and fit the plugs provided to the holes.

Reposition the appliance and screw the lower brackets in place with the screws provided.

Level the appliance and tighten the brackets together.

Supply Pressures

The appliance is connected directly to the gas supply where the gas supply pressure is controlled at the source of inlet in the building or via the governor attached to the bottle gases. See Technical Data for the supply pressures.

Undo the screw and attach a pressure gauge to the boss of the test nipple which is located on the gas inlet pipe.

Light the oven burner and set thermostat to the highest setting and check the pressure.

For Propane with a 50mbar supply pressure a governor is required for adjustment to 37mbar.

(For J10, set each side individually)

Commissioning must include a functional check of all controls and a calibration check on the thermostat. Oil temperature should be checked once the main burners have cut out for a second time.

Upon handover, ensure all operators know how to safely light, operate and shutdown the appliance and are aware of the isolating cock.

OPERATING INSTRUCTIONS

This appliance is for professional use and must be operated by qualified or trained personnel only.

This unit is intended to be used to produce deep fried products only.

Operator precautions

Do not leave the appliance unsupervised whilst operating.

Never put water in the oil and always drain food of excess moisture before frying.

Avoid overloading the baskets with product.

Do not use dust cover lid whilst operating.

Always allow oil or fat to cool before replenishing – do not attempt to add cold oil to hot whilst cooking.

Notes on frying

Good quality vegetable oil is recommended, which has a higher smoke and fire temperature than animal fat, and also carries less taint when different products are fried in the same oil.

The life expectancy of oil will lengthen with regular filtering, and will also be extended if the appliance is turned to standby when the fryer is not in use.

Old oil becomes more prone to boil or surge. It also has a lower flashpoint and will be prone to overheating. Changing oil frequently reduces the risk of a fire hazard.

It is advisable to defrost frozen food first – cooking from frozen will affect the heating recovery time, lowering output.

Always allow the oil to heat to temperature before introducing product.

Preparation for use

Ensure the drain valves are closed.

Fill the tanks with water and a little mild detergent to the lower indicated mark on the batter plate. Do not use flammable solvents and cleaning aids.

Following the Lighting Instructions, turn the appliance on and allow the water to boil for a short time.

Switch off and drain the water.

Rinse the tank and dry thoroughly.

Run a small quantity of oil around the whole of the tank and allow it to drain. This will remove any residual water and provide the tank with a coating of oil.

Close the drain valve, fit the blanking nut and fill the appliance with clean oil to the lower level, maintain oil at the upper level during service.

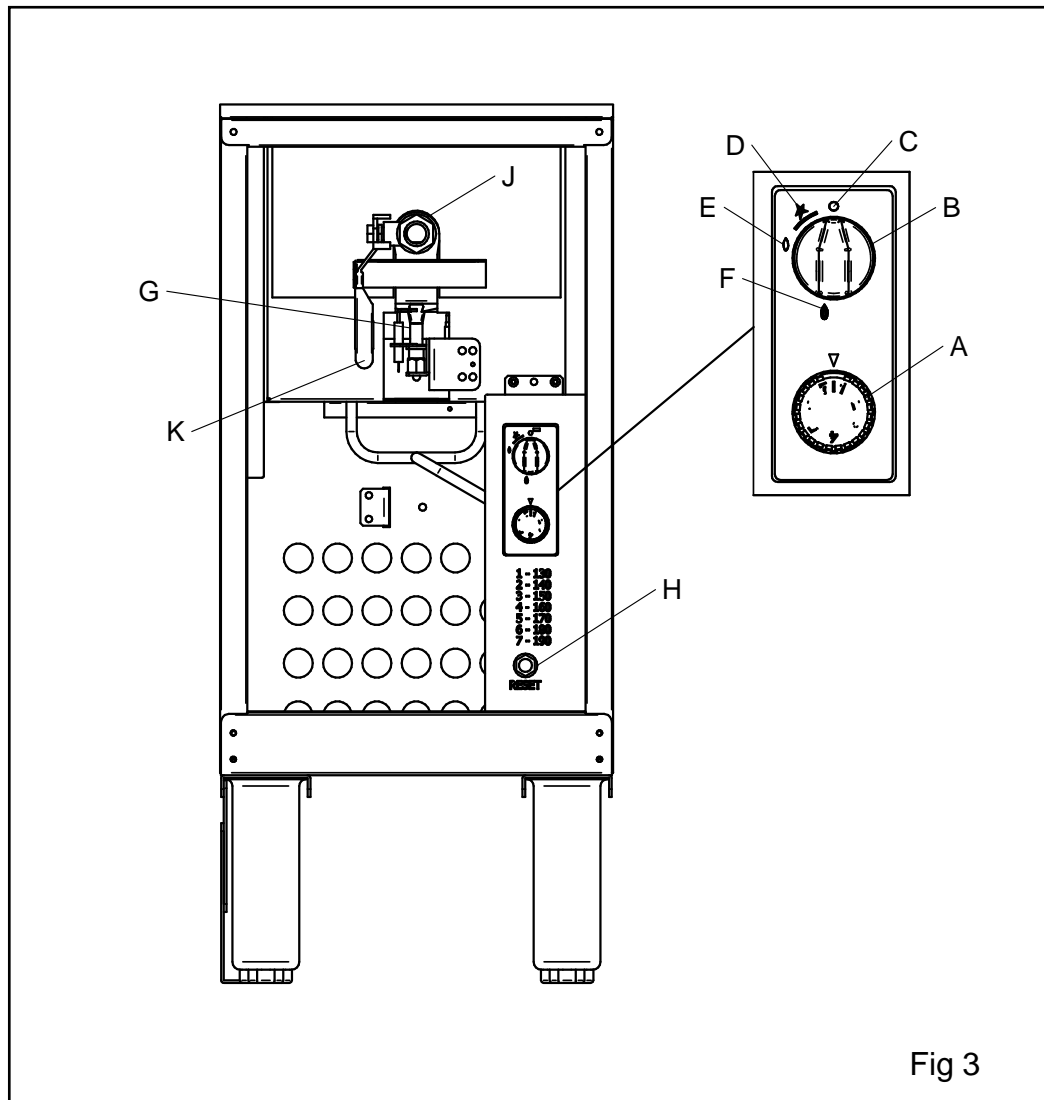

Fig 3

Lighting

Ensure that the supply isolation valve is open.

Ensure the control knob (Fig 3 B) is in the 'Off' position (Fig 3 C). Push in and turn anticlockwise to the pilot position (Fig 4 E) during which the piezo igniter will click to ignite the pilot.

When the pilot is lit keep the knob depressed a further 20 seconds to establish the pilot flame. If the pilot fails to light, return the knob to the 'Off' position, allow time for the control to reset and then repeat the process.

To operate the main burner with the pilot lit, turn the control knob to the operating position (Fig 3 F) and turn the thermostat control knob (Fig 3 A) to the required setting.

If for any reason the burner runs and then fails, the valve may go in to 'lockout' mode – see note under **Shut down** section.

Standby

The appliance may be left on standby by lighting the pilot and leaving the control knob in the pilot position (Fig 3 E). The main burner cannot be operated in this position. To re-ignite the main burner, follow the instructions above.

Safety cut-out

Should the safety thermostat operate during use, the appliance will shut down. Allow the oil to cool before resetting the thermostat by depressing the red button (Fig 3 H).

Shut down

When the appliance is not required, turn the control knob (Fig 3 B) to the pilot position (Fig 3 E) which will shut down the main burner but leave the pilot lit ready for when the appliance is next required.

To turn the appliance off fully, turn the control knob (Fig 3 B) to the 'Off' position (Fig 3 C) and shut off at the gas supply.

Drainage

Allow the oil to cool below 55 Deg C before draining.

Remove the blanking nut (Fig 4 J) from the front of the appliance. Fit the drain tube. Place a suitable receptacle under the pipe outlet. Lift the drain valve handle lock (Fig 4 K) to allow operation of the drain valve, then move the drain valve handle forwards and upwards to drain. After draining, close the valve, remove the pipe and refit the blanking nut. Excess oil remaining in the base of the tank can be removed with kitchen paper.

Ensure the handle lock has dropped into position before refilling the tank.

CLEANING



Do not use a water jet or steam cleaner, and do not immerse this appliance.

Drain as per the above instructions. Clean all panels with warm water and mild detergent do not use abrasive or flammable materials. Dry with a soft cloth.

Clean the drain valves from both inside and outside with a tube or flue brush.

SERVICING, MAINTENANCE AND COMPONENT REPLACEMENT

All servicing, maintenance and component replacement on this appliance should be carried out by one of our recommended service engineers.

Routine Service

A general check on the installation should pay particular attention to the following:

That the correct hose has been used which is compliant with national requirements and that it is in good condition. Replace if necessary.

That there is a safety chain fitted.

That there is a separate isolation valve.

Specific checks should include:

Burner operation, flame picture, signs of debris or damage.

A check that the pilot flame is burning correctly, cleaning of the pilot components if necessary.

Operation of the safety thermostat.

Observation that the flue is clear.

A gas soundness check.

Component Replacement

Access to the ignition system components most liable to need replacing is best obtained by removing the complete ignition assembly from the fryer. Referring to Fig 4, this may be achieved by undoing the pilot nut (A) from the pilot pipe (B) at the pilot end. Ensure that the pilot jet (D) is not dropped. Next, release the holding bolts from the bracket (C) and lower the assembly clear of the unit. Replace the specific part as detailed below, and reassemble in the reverse order.

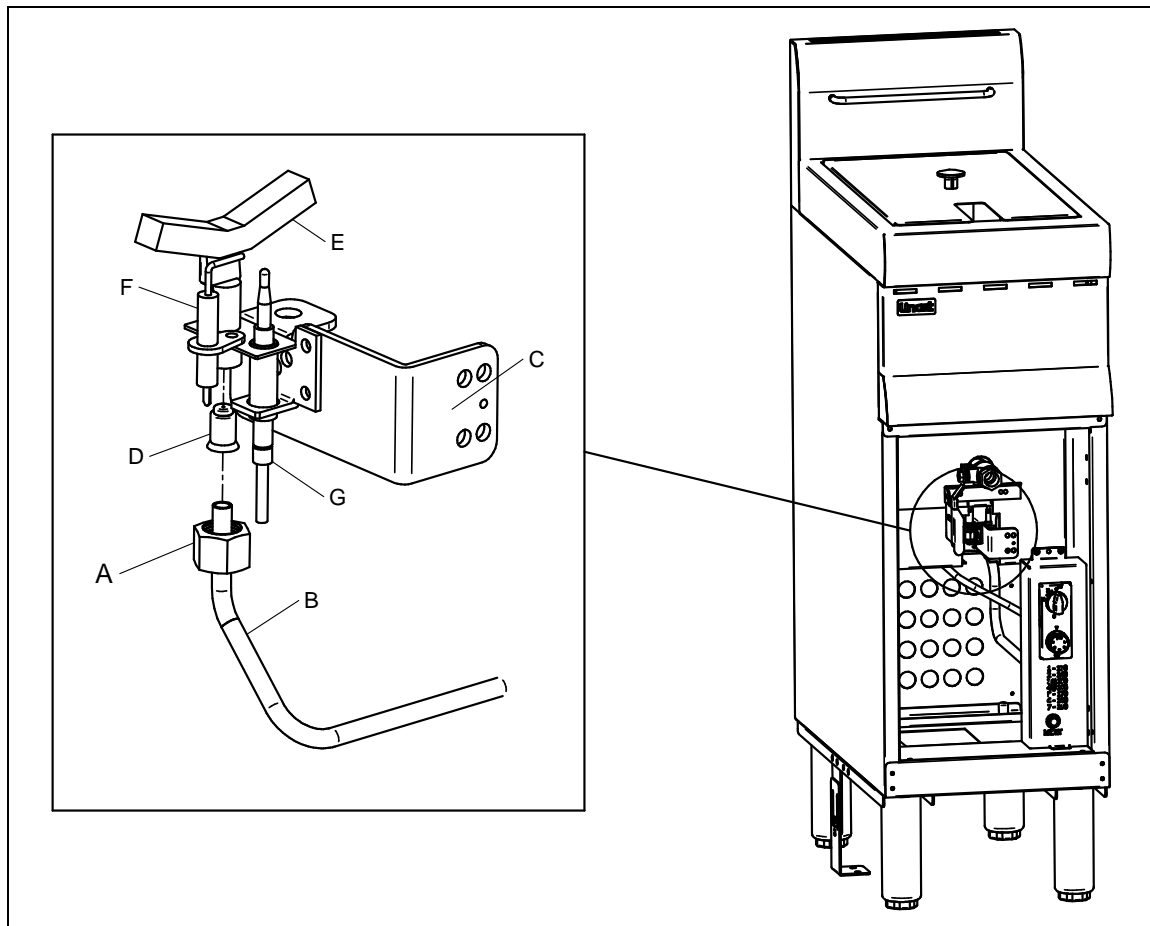

Fig 4

Igniter electrode and Pilot jet

Remove the ignition assembly as detailed above.

Disconnect igniter lead from igniter.

Remove screw holding igniter electrode.

Reassemble by reversing above. Ensure pilot jet is refitted when fitting pilot pipe.

Thermocouple

Remove the ignition assembly as detailed above.

Undo the nut from the pilot body which secures the thermocouple to the pilot body and pull down.

Undo the nut holding the thermocouple into the rear of the valve.
Disconnect wiring from the interrupter thermocouple block.

Replace thermocouple and reverse procedure for reassembly.

Multi Function Control Valve (M.F.C.).

Undo the two screws and remove the M.F.C. cover plate.

Disconnect the wires from the interrupter then disconnect thermocouple.
Remove the interrupter then disconnect all pipe work – pilot, gas supply and burner.

Disconnect the ignition lead from the M.F.C.

Locate the retaining screw in the lower rear of the M.F.C. undo and remove the valve.

Remove compression fittings from old valve and fit to replacement. Fit the supplied blanking plugs as per the old valve. Do not reuse the old blanking plugs.

Reverse the above for reassembly.

Safety Thermostat

Drain oil from tank.

Remove thermostat phial cover and securing bracket.

Remove the fascia panel. Undo gland nut at front of tank.

Carefully withdraw thermostat phial through tank – there will be resistance due to packing behind the gland nut becoming compacted.

Undo the two screws and remove the M.F.C. cover plate.

Slide up the cover to gain access to the capillaries for ease of removal and refitting.

Disconnect wiring from thermostat.

Undo the the locknut from the thermostat body and remove.

Reverse the above for reassembly.

FAULT FINDING

Piezo igniter not sparking

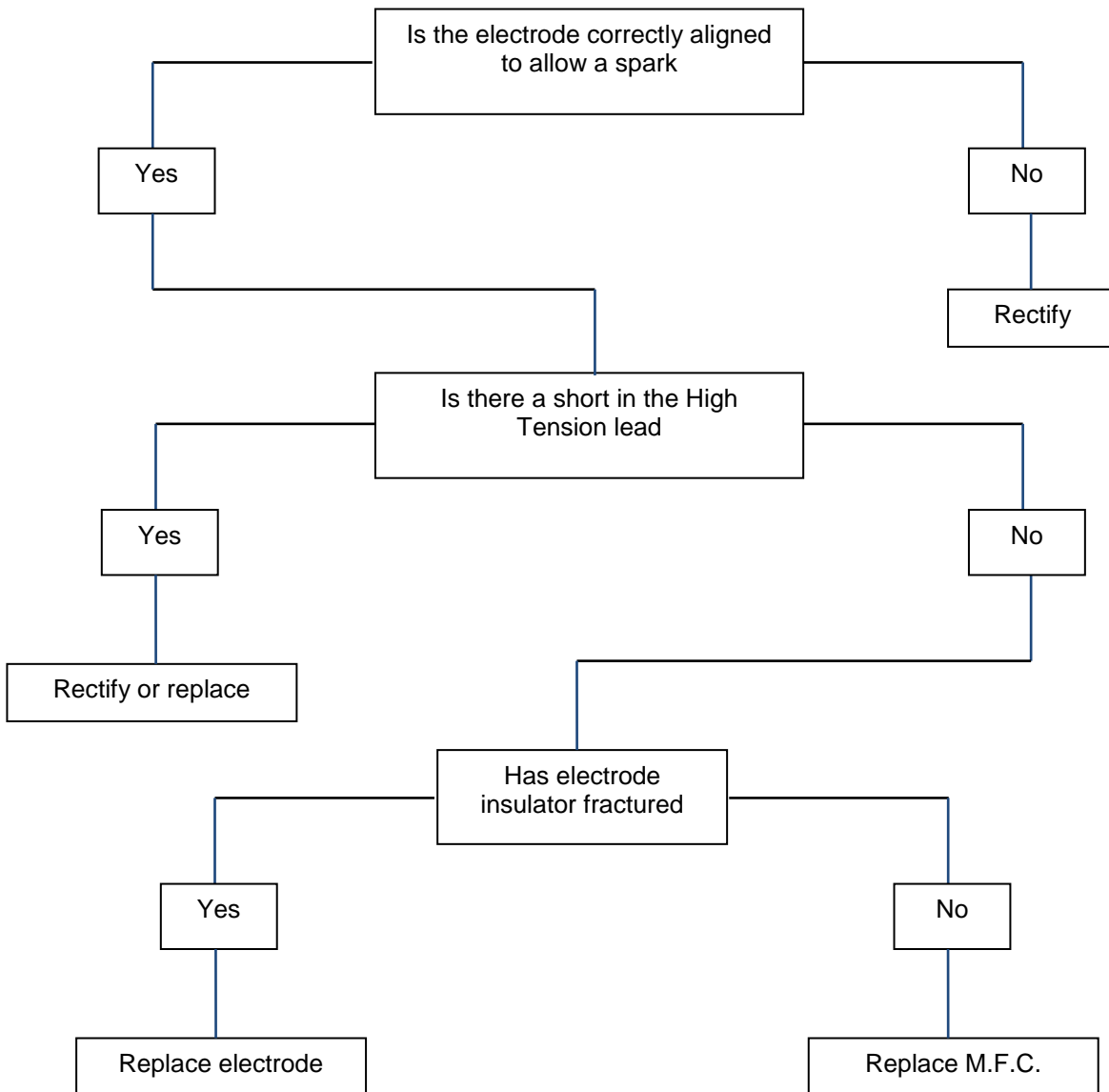

Pilot burner will not light or stay lit

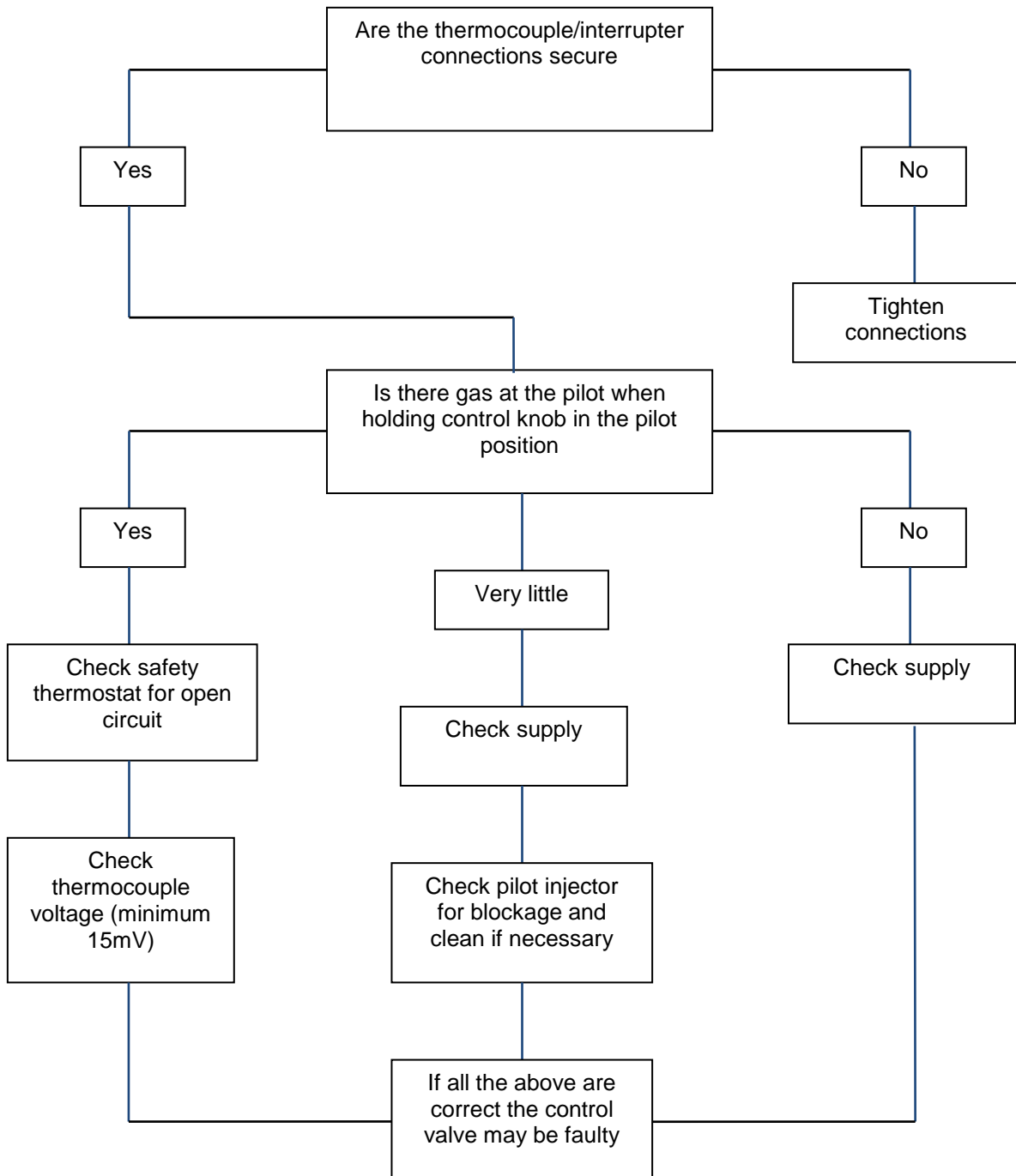

Main burner will not light

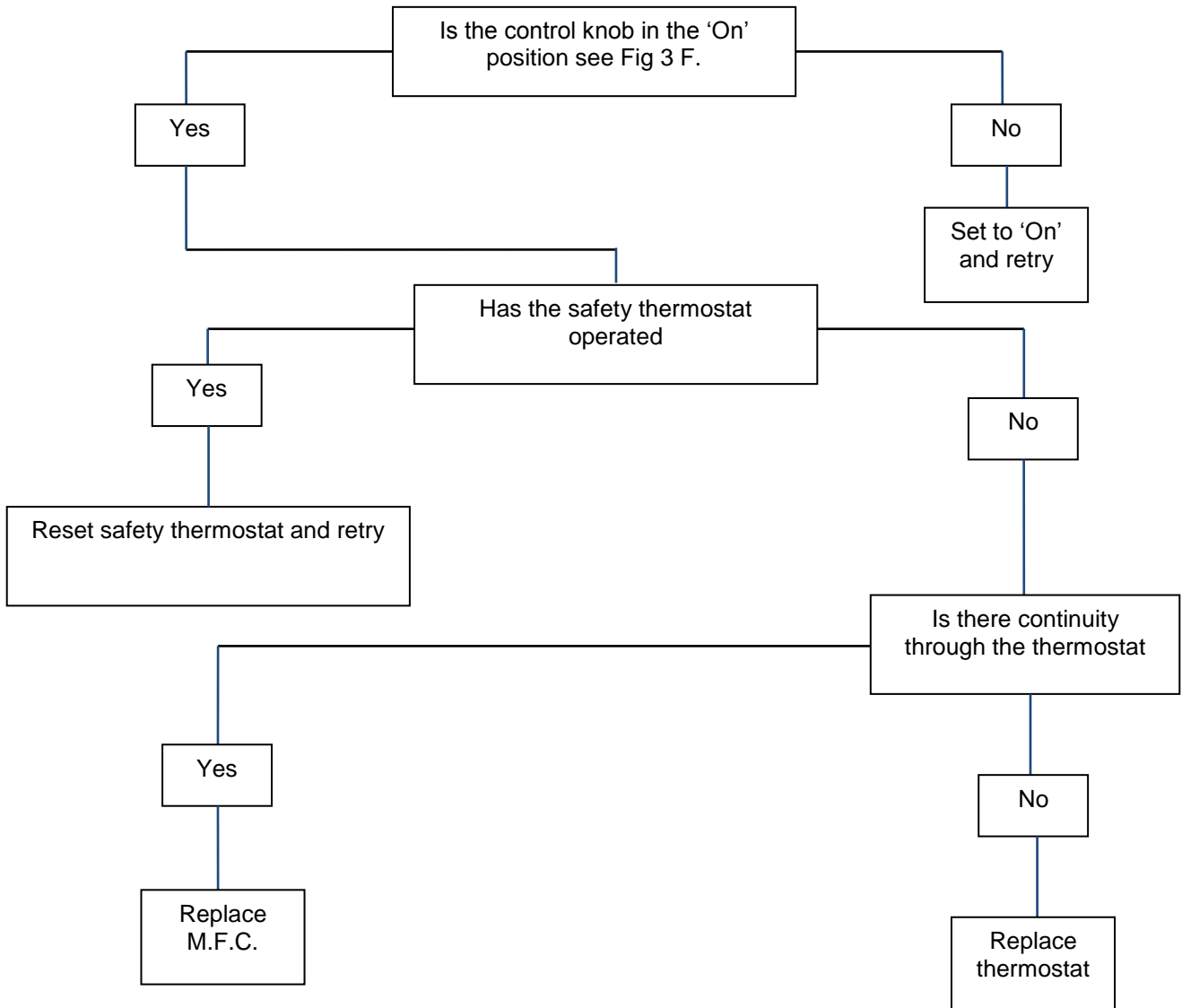

Safety thermostat operates

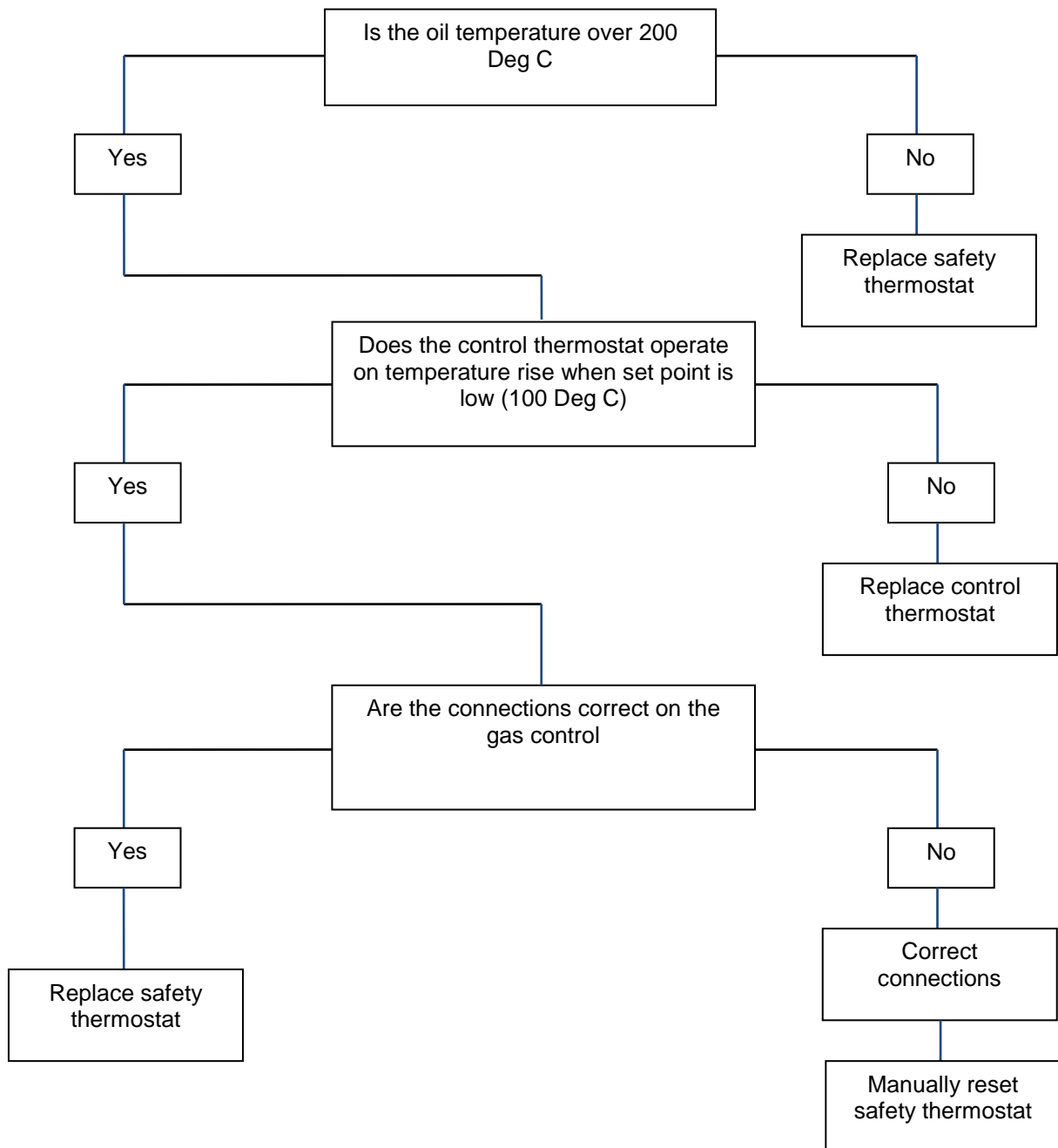

SPARE PARTS LIST

Part Number	Description	Used on
BA98	Basket	All
BU43	Burner	
FE29	Leg	
IG06	Igniter lead	
IG14	Igniter electrode	
JE31 (26N).	Pilot jet	J5/N, J10/N
JE32 (LP16).	Pilot jet	J5/P, J10/P
JE46 (440).	Burner jet	J5/N, J10/N
JE13 (200).	Burner jet	J5/P, J10/P
PI25	Pilot assembly	All
TC03	Thermocouple	
TH129B	Safety thermostat	
VA80	Valve	

SERVICE INFORMATION

For help with the installation, maintenance and use of your **Lincat** equipment, please contact our service department:

☎ UK: 01522 875520

For non-UK customers, please contact your local Lincat dealer

All service work, other than routine cleaning **MUST** be carried out by qualified personnel and a record kept of any remedial actions taken and at least cover the requirements of the service schedule of this document. We cannot accept responsibility for work carried out by other persons.

To ensure your service enquiry is handled as efficiently as possible, please tell us:

- Brief details of the problem
 - Product code
 - Type number
 - Serial number
- } All available on serial plate

Lincat reserve the right to carry out any work under warranty, given reasonable access to the appliance, during normal working hours, Monday to Friday, 08:30 to 17:00.

DECLARATION

All Lincat products capable of burning gaseous fuels, satisfy the requirements of the Gas Appliance Regulations 2016/426.

GUARANTEE

This unit carries a comprehensive UK mainland warranty. The guarantee is in addition to, and does not diminish your statutory or legal rights. Contact Lincat for terms and conditions

The guarantee does not cover:

- Accidental damage, misuse or use not in accordance with the manufacturer's instructions
- Consumable items (such as filters, glass, bulbs, slot toaster elements and door seals.)
- Damage due to incorrect installation, modification, unauthorised service work or damage due to scale, food debris build-up, etc.

The manufacturer disclaims any liability for incidental, or consequential damages. Attendance is based on reasonable access to the appliance to allow the authorised personnel to carry out the warranty work.

Service calls to equipment under warranty will be carried out in accordance with the conditions of sale. Unless otherwise specified, a maximum of 15 minutes of administrative time, not spent directly carrying out servicing work, is provided for within the warranty. Any requirement for staff attending the call to spend greater time than 15 minutes due to administrative requirements, such as on health and safety risk assessments, will be chargeable at the prevailing rate.

Notes