

GAS CREPE MAKER

USER'S MANUAL



A. INTRODUCTION

The body of this machine is made of stainless steel. Cast iron heaters save energy and the machine is durable with good looking. Independent ignition device and gas valve with safety flameout device can keep the user be safe.

These instructions are only valid if the country code appears on the appliance. If the code does not appear on the appliance, refer to the technical instructions for adapting the appliance to the conditions for use in that country

B. FEATURES

1. High efficacy burner can heat fast and evenly. The thick cast iron plate can work continuously to cook food.
2. Console style design and all stainless steel structure with down storage cabinet. It is very solid and durable.
3. Burner can be controlled and gas valve with safety flameout device can keep safety.

C. PARAMETER

NAME	GAS CREPE MACHINE
MODEL	CM-1G
DIMENSION	450×515×335mm
SWITCH	1
SIZE OF GRIDDLE	Φ400×20 mm
Injector size	1mm for LPG, 1.8mm for NG

NG data plate template

		 0063-23 Pin 0063CU7296		
Product Name	Gas crepe maker			
Model Number	CM-1G			
Appliance type	A ₁			
Cat	I _{2H} <input checked="" type="checkbox"/>	I _{2E}	I _{2E+}	I _{2EK}
Country code	AT, BG, CZ, DK, GB, EE, FI, GR, HR, HU, IS, IE, IT, LV, LT, NO, PT, RO, SK, SI, ES, SE, CH, TR, GB	DE, LU, PL, RO	BE, FR	NL
Gas Type & Pressure	G20:20mbar	G20:20mbar	G20/G25: 20/25mbar	G25.3: 25mbar
Total Heat Input ($\sum Q_n$)	5.2 kW (550l/h)	5.2 kW (550l/h)	5.2 kW (550l/h)	5.2 kW (625l/h)
Direct Country of Destination	GB			
<p>⚠ CAUTION: Install the appliance in a suitably ventilated room. This appliance shall be installed in conformity with the current regulations and used only indoor in a well-ventilated location. Consult the instructions before installing and using this appliance.</p>				

LPG data plate template

		 0063-23 Pin 0063CU7296		
Product Name	Gas crepe maker			
Model Number	CM-1G			
Appliance type	A ₁			
Cat	I _{3+(28-30/37)} <input checked="" type="checkbox"/>	I _{3B/P(30)}	I _{3B/P(37)}	I _{3B/P(50)}
Country code	BE, CH, CY, CZ, ES, FR, GB, GR, IE, IT, LT, LU, LV, PT, SK, SI.	BE, CY, DK, EE, FI, FR, HU, IT, LT, NL, NO, SE, SI, SK, RO, HR, TR, BG, IS, LU, MT	PL	AT, CH, DE, SK
Gas Type & Pressure	G30:28-30mbar G31:37mbar	G30 /G31: 30mbar	G30/G31: 37mbar	G30 /G31: 50mbar
Total Heat Input ($\sum Q_n$)	3.3 kW (260g/h)		3.6 kW (284g/h)	4.5 kW (355g/h)
Direct Country of Destination	GB			

⚠ CAUTION:

Install the appliance in a suitably ventilated room.

This appliance shall be installed in conformity with the current regulations and used only indoor in a well-ventilated location. Consult the instructions before installing and using this appliance.

Injector Size and marked

Cat.	Injector size (mm)
I3B/P (30), I3+(28-30/37) , I3B/P (37), I3B/P (50)	1.0
I2H, I2E, I2EK, I2E+	1.8

The min temperature of hottest point of the solid top is 250 °C

D. INSTRUCTION

1. This machine should be put on a stable place and its back should be away from wall more than 10cm and its two sides should be away from any flammable objects more than 10cm for safety sake. This machine should be placed in a ventilate environment. Do not put any sundry in front of switch for convenient operation.
2. All users must observe gas operation standard and check all connection of gas and machine is no leakage and all gas valves are shut.
3. All operation must be kept in safety situation then use the machine. If any troubles happen, please maintain it at once.
4. Before this machine being using, please install and adjust it correctly. After all checking and make sure all are safe and all right then operate the machine.
5. The circuit checking and installation of the machine should be done by professionals. If gas leakage happens, shut off gas valve and keep environment be ventilated. Do not turn on any power or ignition and repair the machine.
6. Check the gas supply pressure after installation.
7. Gas supply pressure can be measured with a liquid-filled pressure gauge (e.g. a U-shaped pressure gauge, minimum scale division 0.1mbar) or a digital gauge. Procedure as follows:
8. these appliances are to be installed with sufficient ventilation to prevent the occurrence of unacceptable concentrations of substances harmful to health in the room in which they are installed.
 - Remove the panel, unscrew the screw on the pressure port (Picture 1);
 - Place the pressure gauge;
 - Start up the appliance by following the instructions in the user's manual;
 - Check the supply pressure;
 - After the check, remove the pressure gauge;
 - Replace the sealing screw.
 - The test point pressure please refer to the data label to different gas type.

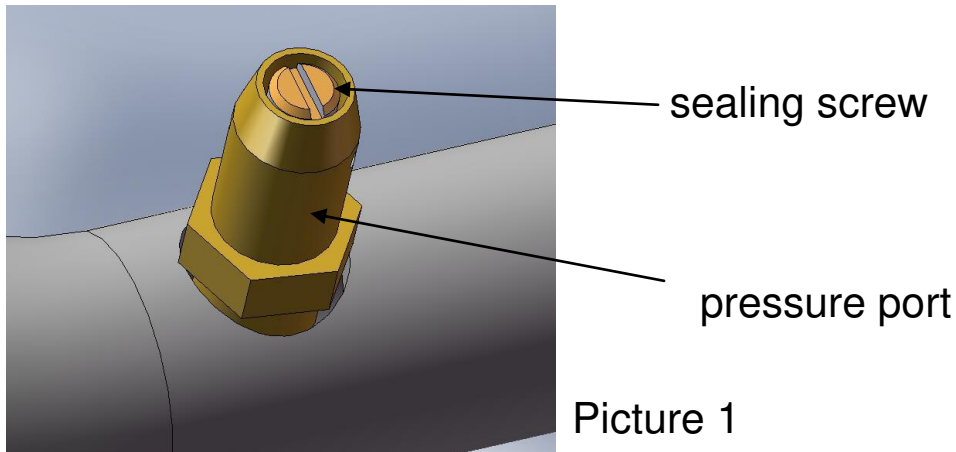

E. GUARANTEE

1. The usage of this machine is only frying food. The follow situation is not in maintenance range.
 - a. Unsuitable operation
 - b. Wrong installation or unsuitable maintenance
 - c. While the parts are damaging go on using the machine
 - d. Change parts without the permission in writing by agents

F. GAS INSTALLATION

1. Before using, please shut off all gas valve.
2. Use gas and make sure the connection of this machine is firm.
3. Do not use middle and high pressure valve.
4. It is essential that the gas supply is correct for the appliance to be installed and that adequate supply pressure and volume are available. The following checks should therefore be made before installation:-

Gas Type required for the appliance is shown in the rating label. Check that this is correct for the gas supply the appliance is being installed for gas crepe maker. The gas conversion is not suited for gas crepe maker.

Supply Pressure required for this appliance is shown in the 'Gas supply requirements' section of this manual. Check the gas supply to ensure adequate supply pressure exists.

Input Rate of this appliance is stated on the Rating label. The input rate should be checked against the available gas supply line capacity. Particular note should be taken if the appliance is being added to an existing installation.

The gas supply tubing or hose shall comply with the national requirements in force and shall be periodically examined and replaced as necessary.

Only local national requirements rubber or PVC flexible hose(Nominal core of hose shall be 6.3mm to12.5mm) could be used for LP gas connection. The length of flexible hose shall not be more than 1.5meters. The flexible hose shall not come into contact with sharp edges.

LP Gas Regulator, flexible hose adaptor and rubber gasket shall be matched with local national requirements, A Manual Isolation Valve must be fitted to the individual appliance

supply line. The regulator should be certificated according to EN16129 latest version. And the hose should be Certificated according to the latest version EN 16436-1, BSEN ISO3821, BSEN1327 or DIN 1763

Nature gas shall be connected with from nature gas supply pipe to nature gas regulator and connection adaptor to match with local national installation requirements. The nature gas supply line must be at least the equivalent of ½” (12.7 mm) iron pipe for single units, A Manual Isolation Valve must be fitted to the individual appliance supply line.

5. Do not connect the appliances to networks containing gases containing carbon monoxide or other toxic components;
6. When installing the appliance, please verify that the current state adjustment of the appliance is compatible with the local distribution conditions, nature of gas and pressure; and if applicable, the local electrical supply conditions are compatible with the electrical data given on the data plate

G. OPERATION

1. Clean the cast iron and check the gas valve is shut off.
2. Get through gas supply and check everything is all right then operate the machine.
3. Push down the control knob.
4. While pressing, turn the control knob to the Max.
5. While knob is in this position, press the ignition button several times.
6. Keep the control knob pressed for 10-15 seconds till flame remain lit.
7. Move the control knob to the desired setting between MAX and MIN.
8. If the flame fails to remain lit, repeat above procedure 3~6.
9. Turn the control knob to the “Off” position to extinguish the machine.

CAUTION:

- This appliance is for professional use and is only to be used by qualified persons.
- Only authorized service persons are to carry out installation, servicing or gas conversion operation operations.
- Components having adjustments protected by the manufacturer should not be adjusted by the user/operator.

H. CLEANING AND MAINTENANCE

1. While cleaning, please shut all valve in case of accident happens.
2. After the machine finishes working , please clean the surface of the griddle and brush fresh edible oil.
3. Then wipe the machine with wet towel but do not wash it with a water jet prevent from damaging function.
4. After cleaning, please put all parts on a good place and cover the machine with dustproof paper.

I. TRANSPORTATION AND STORAGE

During transportation, the machine should be careful handled and prevent from shaking. The packaged machine should not be stored in open air long. It should be put in a ventilated warehouse without causticity gas. And it should not be put up side down. If it needs to be stored in open air temporarily, measurement against raining is needed.

K. Gas conversion Instructions

Instructions For Field Conversion To LP Gas:

This instruction covers the following gas equipment, including gas crepe maker.

Please refer to specific instructions for each model range

WARNING:

Improper installation, adjustment, alteration, service or maintenance can cause property damage, injury or death. Read the installation, operating and maintenance instructions thoroughly before installing or servicing equipment.

WARNING

This conversion kit shall be installed by a qualified service agency in accordance with the manufacturer's instructions and all applicable codes and requirements of the authority having jurisdiction. If the information in these instructions is not followed exactly, a fire, an explosion or production of carbon monoxide may result causing property damage, personal injury or loss of life. The qualified service agency is responsible for the proper installation of this kit. The installation is not proper and complete until the operation of the converted appliance is checked as specified in the manufacturer's instructions supplied with the kit

Specific Instructions



CAUTION:

**ENSURE THE GAS SUPPLY IS SHUT OFF AT THE
MANUAL SHUT OFF VALVE BEFORE PROCEEDING
WITH THE CONVERSION**

Switch off the gas at the main supply valve and allow the unit to cool down before commencing with the conversion.

Take off the bottom plate to expose the injector and control valve.

Change the main burner injector:

Loosen and remove the brass orifice located on the end of the burner with a wrench.

Replace with the new orifice from the conversion kit, first applying a small amount of jointing paste to the thread on the end of the nozzle holder, this will ensure a good gas tight seal.

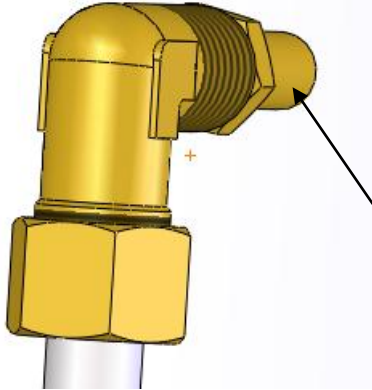

flame adjustment

When changing from natural gas to LPG, it is necessary to adjust the burner flame as well. Please adjust the flame as below.

Take off valve knob. Use a screw driver to adjust the flame height to a desired flame. Rotate below arrowed pin clockwise, the flame height would be reduced. Rotate it anti-clockwise, the flame height would be higher.



Trouble Shooting

This section provides an easy reference guide to the more common problems that may occur during the operation of your equipment. The fault finding guide in this section is intended to help you correct, or at least accurately diagnose problems with your equipment.

Although this section covers the most common problems reported, you may encounter a problem not covered in this section. In such instances, please contact your local authorized service agent who will make every effort to help you identify and resolve the problem. Please note that the service agent will require the following information:

- Model Code and the Serial Number of the appliance. (Both of them can be found on the Rating Plate located on the appliance).

Fault	Possible Cause	Remedy
Main burner will not light.	Insufficient gas pressure in pipe	Contact the local gas supply dept.
	No gas supply.	Ensure gas isolation valve is turned on, and that bottles are not empty. Call the service provider. .
	Nozzle occlusion	Dredge nozzle
	Thermocouple connection loose	Tighten thermocouple
	Thermocouple damage	Replace thermocouple
	Gas control valve failure	Replace control valve
No spark flame on main burner	Faulty electronic pulse ignition device	Replace electronic pulse ignition device
Yellow flame and black smoke	Use the gas of bottom	Replace gas
	Not match nozzle diameter with gas resources	Adjust nozzle diameter
	Not enough air to ignite	Increase damper opening degree
	In the peak of using gas, sources of gas float heavy	Turn down valves flow. Turn it up after the peak

The problems mentioned above are only for reference. If any fault occurs, please stop using, and contact technicians to check and repair. Safety first, turn off the power and gas supply before maintenance.

Exploded diagram

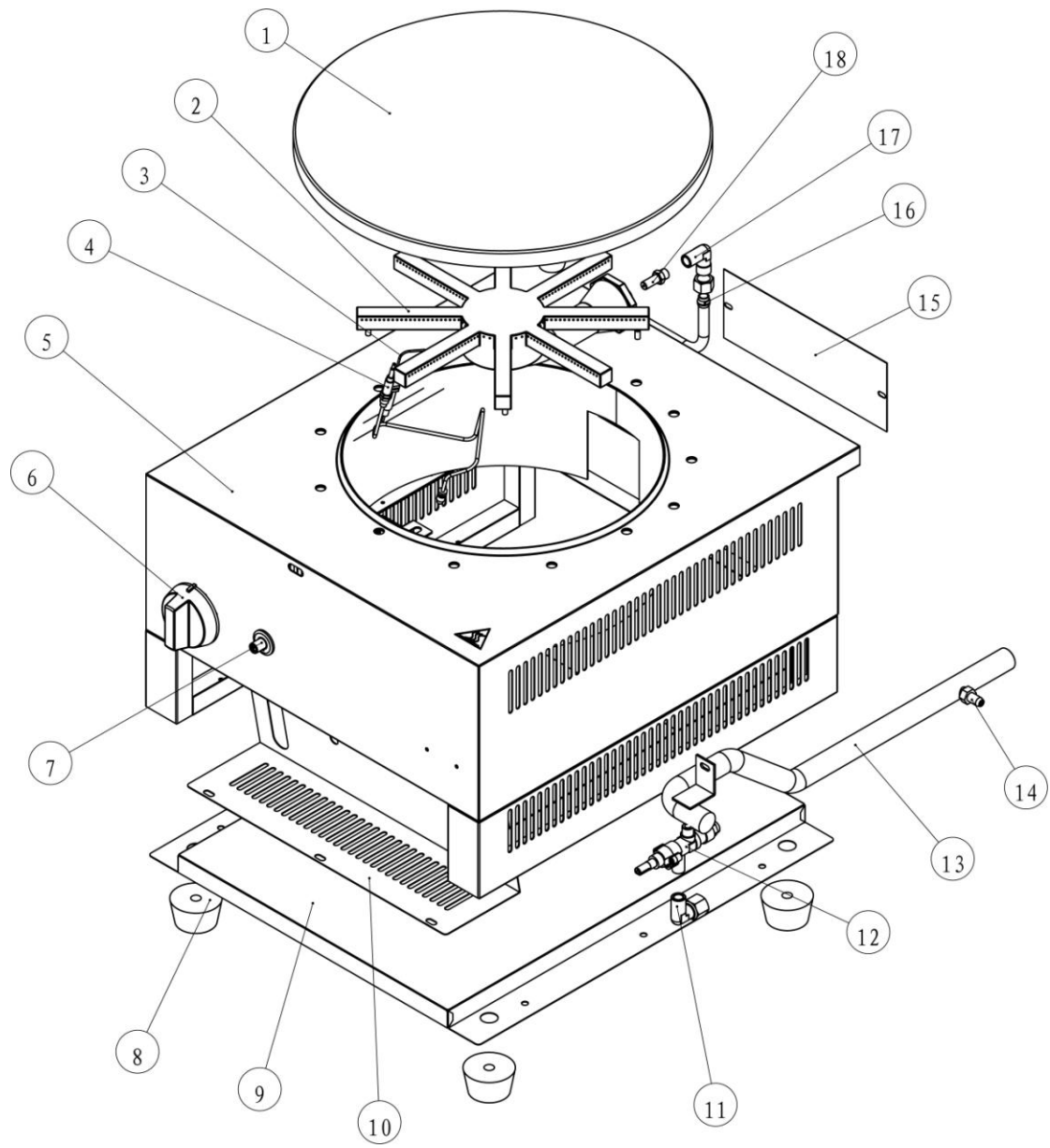

Part list

S e r i a l n o .	Description	Qty
1	Cast iron plate	1
2	Burner	1
3	Ignite needle	1
4	Thermocouple	1
5	Body Assy	1
6	valve knob	1
7	ignition	1
8	Rubber foot	4
9	Bottom Plate	1
1 0	Front insulation panel	1
1 1	Elbow (NPT 1/8)	1
1 2	Gas Valve	1
1 3	Gas Pipe	1

1 4	Pressure port	1
1 5	Access cover for shutter	1
1 6	Clamp	1
1 7	Connector(90°, \varnothing 10)	1
1 8	Jet	1

Please keep this manual in a safe place for future use!