

**INSTRUCTIONS FOR USE AND INSTALLATION
ELECTRIC CREPE MACHINE
CFE 400**



Made in France

G03243

December 2011

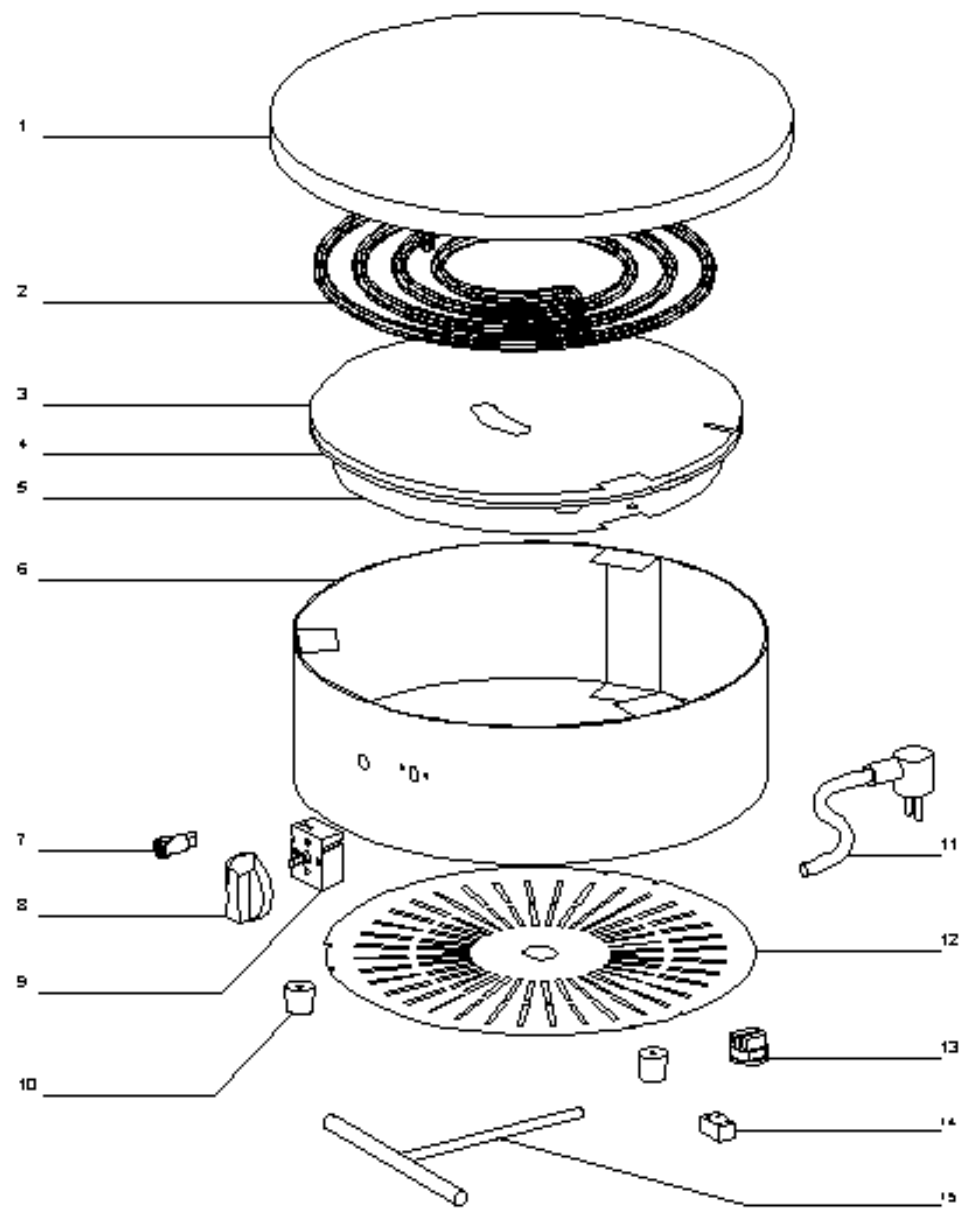

ELECTRIC CREPE MACHINE

CFE 400

Congratulations for the acquisition of this upmarket appliance made in France. You chose an appliance which allows the best technical qualities with a big user-friendliness. We wish you the biggest contentment

Nomenclature **CFE 400**
Spare parts **CFE 400**

Rep	Code	Qty	Pièce	Spare part
1	B02049	1	Disque émaillé 400	Enamelled cast iron plate 400
2	D02172	1	Résistance 3000 W	Heating element 3000 W
3	67049	1	Serre résistance	Heating element holder
4	H02055	1	Isolant	Insulation
5	67048	1	Tôle protection	Protecting S/steel
6	67052SE	1	Ceinture	Casing
7	A08003	1	Voyant orange	Orange pilot light
8	A14078	1	Bouton	Knob
9	A06042	1	Thermostat	Thermostat
10	A13018	3	Pied	Foot
11	C03011	1	Cordon avec prise	Cord with plug
12	67055	1	Fond socle	Bottom casing
13	A10001	1	Serre cable	Cord closer
14	A16021	1	Domino 2 plots	Two holes domino
15	F05017	1	Râteau en bois	Wooden scraper

1. SECURITY INSTRUCTIONS

Please respect these instructions scrupulously to avoid any risk of fire, electric shock, scald or other wounds and damage. During the use of this appliance, fundamental circumspection of security must always be noticed, such as:

- Take into account the instructions to be systematically kept with the appliance.
- Install the appliance always in instructions respect. A 10 cm distance minimum with the partition or the wall is necessary.
- This appliance is marked out for outside use or inside use in a well ventilated room or under a cooker hood
- Protect the appliance from direct light of the sun, frost and humidity.
- Never leave the appliance within the reach of children or disabled persons without surveillance.
- Never move the appliance when it is working or when the cooking surface is still hot.
- Check that the appliance is definitely off before connecting it up or disconnecting it.
- Do not touch the hot surfaces of the appliance. The temperature of the hot surfaces can be very important when the appliance is working. Always use handles and control knobs.
- Do not use the appliance for other functions than determined use.
- Do not leave the cord of electrical feeding in the contact of hot surfaces.
- The appliance should not be used close to combustible materials.
- During use, look after not to obstruct hearings of aeration of the appliance
- To avoid any electric shock, never plunge the appliance, the cord or plug in water or quite other liquid.
- If the cord is harmed, it must be replaced by the producer, his after sale service or persons of similar skills to avoid any risk.
- Entrust compensations only to a skilled person.
- Use only spare parts of origin.
- At the end of cooking, before cleaning the appliance, do not forget to disconnect it.

2. CONTENTS OF CARDBOARD PACKAGING

- Device: a crepe machine
- Accessories: - A wooden crepe rake
- The present note

See exploded view of CFE 400 at the end of the document

3. CONFORMITY OF USE

Use the device only to cook crepes, pancakes, buckwheat cakes...

4. WAY OF FUNCTIONING

This crepe machine is a strong cooktop in enamelled cast iron. The strong thickness of the plate ensures an excellent homogeneity and a stability of the temperature. The plate's smooth surface provides direct heat transfer to the food being cooked, without heat loss at the centre as in the periphery thanks to spiral heating element integrated under the cast iron plate that cover the entire cooking surface.

To turn on and preheat the plate, just turn the thermostat control knob (n°2 on picture) on the wished position. The orange pilot light ignites (n°1 on picture), the crepe machine is heating. When orange pilot light switches off, the device is ready for the cooking.

During cooking, the temperature can be regulated thanks to thermostat control knob (n°2 on picture) to avoid phenomenon of overheating. Orange pilot light (n°1 on picture) indicates heating periods.

A crepe is cooked at a temperature around 200-220°C (position 5-6)



- 1 Thermostatic pilot light
- 2 Thermostat control knob

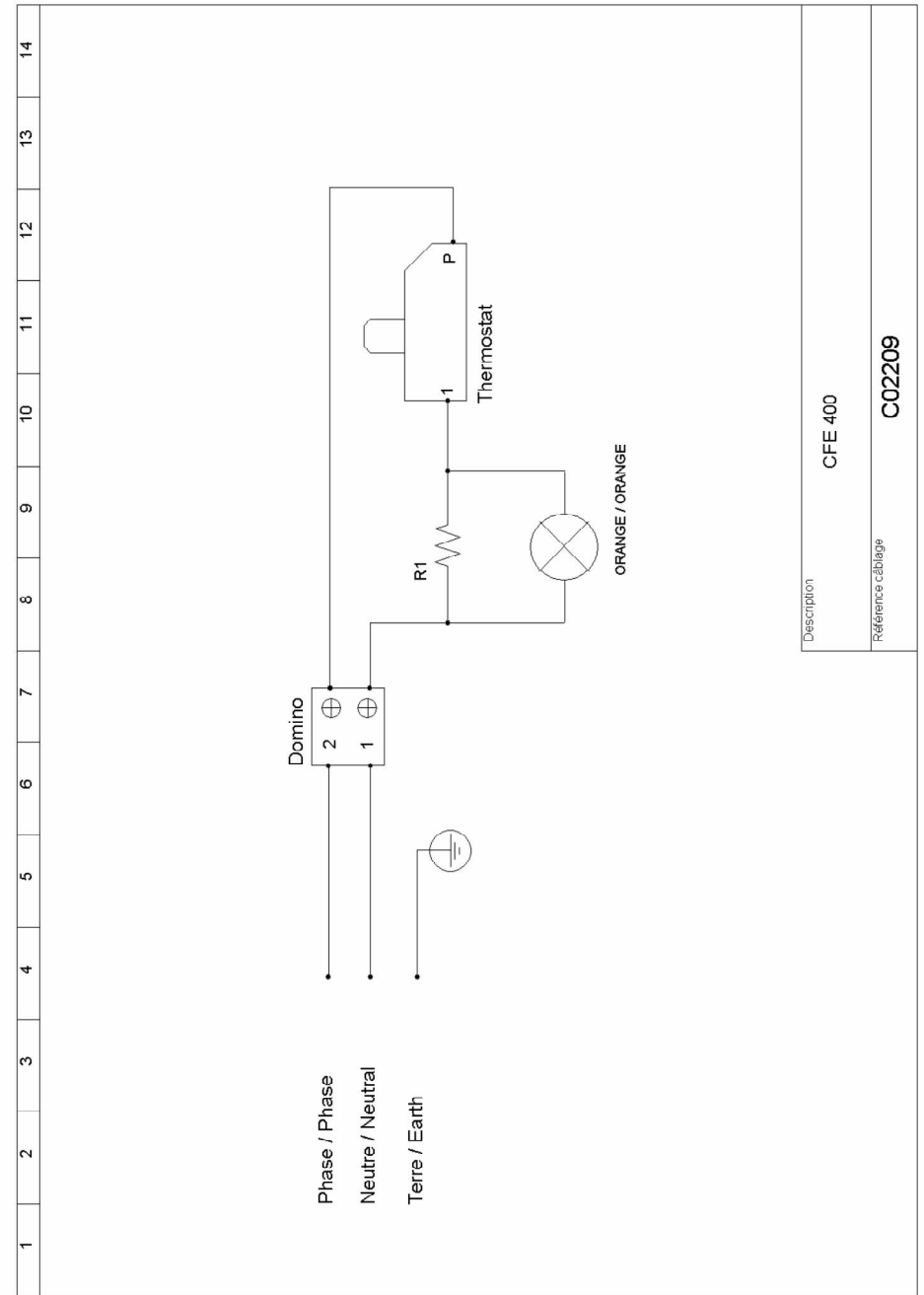

10. GUARANTEE

Conditions of guarantee

The guarantee applicable to any device is the commercial guarantee of the distributor or the retailer. Please contact the store where you bought your device to know the precise conditions.

The guarantee grants no right for damages.

The dispositions which follow are not exclusive of the profit of the legal guarantee planned by articles 1641 and following ones of the Civil code relative to the defects and the latent defects.

Exclusion clauses of the guarantee

Bad installation and bad maintenance, in particular if they do not respect current regulations or instructions appearing in this user guide.

Cannot benefit from the guarantee the repairs required as a result of false operations, of inappropriate use, of carelessness or of excess loads of the device, as well as those resulting from variations of the power supply, over tension or from defective installations.

The damage due to shocks, bad weather is not flatware by the guarantee. The material travels at the risks of the user; in case of delivery by carrier, the consignee has to have reservations towards the carrier before any delivery of the device.

The guarantee comes to an end in case of intervention, of repair, of modification by no qualified persons, or of use in inappropriate purposes.

5. FUNCTIONING / MANIPULATION

a) Installation / assembly:

- Unpack carefully the device of its packaging.
- Place it on a plane and heatproof surface.
- Never place the device near a wall or near a partition makes of combustible materials even if it is very well isolated.
- A distance of minimum 10 cm with the partition or the wall is necessary.

b) First starting:

Before the first use, remove the anti-corrosion protection fat with a cleaner and a wet sponge.

During the first use, grease your plate with oil and preheat the crepe machine during about 15 min. Once preheating is finished, set the thermostat on the wished temperature.

First cleaning

Clean the device before the first use. (See 6. Cleaning)

Connection of the device

- Check that the tension and the frequency of the electricity network suit to the values indicated on the descriptive plate.
- Make sure that every control knob is positioned on 0.
- Check that neither the cord nor the plug are damaged
- Unwind completely the electric power cable and connect it in a plug connected with the earth.
- The device is connected.

NB: in case of connection of the device in a plug without earth protection or directly on the electricity network, confide its connection to a qualified person .

c) Use of device :

Elements of command and display

Command/Display	Function
Thermostat (n°2 on picture)	On/off + Temperature setting
Orange pilot light (n°1 on picture)	Machine is heating (pilot light on) Temperature reached (pilot light off)

Putting on

Turn on the thermostat control knob (n°2 on picture) on the wished position: the orange pilot light (n°1 on picture) ignites. The machine is warming up. Once orange pilot light (n°1 on picture) is off, the machine reached the wished temperature. Grease the plate before each cooking.

Temperature setting

Set the temperature by positioning the thermostat (n°2 on picture) to the desired temperature. The orange pilot light (n°1 on picture) switches on if a higher level of temperature is required and switches off when the same is reached.

It is not necessary to leave the device switched on at full power. It is necessary to adapt the temperature to products to be cooked to limit the energy consumption.

Stopping the appliance

Set thermostat control knob (n°2 on picture) on 0: the appliance is no longer functioning.

Let the device cool

Disconnect the power cable.

Clean the appliance. (see 6. Cleaning)

During non-prolonged use, we recommend you to grease the plate

d) Breakdown / repair:

In case of breakdown or of damaged part, please call your after-sales service and confide any technical operation to qualified person.

When you contact the after-sales service of your distributor or your store, give him the complete reference of your device (commercial name, type and serial number). This information appears on the visible descriptive plate behind the device.

6. CLEANING AND MAINTENANCE

Disconnect the device.

- Let cool completely the device before any technical intervention or cleaning.
- Clean your crepe machine regularly after each use to avoid phenomenon of calamine coming the cooking of the sugar and from some dough which accumulates very quickly, and creates a film on the plate which harms in the quality of the cooking.
- For cleaning, only use non-abrasive products, clean regularly the external walls of your device with warm water and wash liquid: avoid the abrasive towelling. Rinse your device with a wet sponge. Dry it with a soft cloth
- Never clean the device under a water jet, the infiltrations would risk to damage it in a irreparable way.
- Never immerse the device, the cord or the plug in the water or quite other liquid to avoid any electric shock.
- During a prolonged non-use, we recommend you strongly to keep the device shielded from the humidity and to grease the plate.

7. TECHNICAL SPECIFICATIONS

Model	CFE 400
Outside dimensions	400 x 173 mm
Weight	17 Kg
Power	3 000 W
Nbre element	1
Current	13 A
Voltage	220-240 V N~

Wires colours correspondence

Phase
Neutral
Earth

Brown / Black / Grey
Blue
Yellow-Green

8. NORMS AND LEGALS DISPOSALS

The device is conform to :

IEC/EN 60335-1
IEC/EN 60335-2-38
EN 55014-1 + 55014-2
EN 61000-3-2 + 61000-3-3

Humidity protection degrees IPX4, directive from 12/01/2008

9. ELIMINATION OF THE ELECTRIC AND ELECTRONIC WASTE

The device respects the directives:

2002/96/ CE (DEEE) N°34270064800021
2002/95 /CE (ROHS)
2066/95 CE
2004/108 CE



Reach rule

Never put the device among household waste.

The device must be put down in a centre of recycling for the electric equipments.

The materials of the device are indeed reusable. By eliminating correctly the electric and electronic wastes, the recycling and quite other shape of re-use of worn equipments, you participate in a significant way in the environmental protection.

For any information about the collection of electric and electronic waste, please contact your distributor.